

New Challenge for creation—NOK-GROUP



NOK

● Cat. No. 014E-02-2003

OIL SEALS

NOK CORPORATION



CONTENTS

A	What Is An Oil Seal?	A-1~A-4
B	The Sealing Mechanism of an Oil Seal	B-1~B4
C	NOK Oil Seal Types	C-1~C-6
D	NOK Oil Seal Materials	D-1~D-7
E	NOK Oil Seal Application Guide	E-1~ E-15
F	Housing and Shaft Design Guide	F-1~F-15
G	Seal Handling Guide	G-1~G-11
H	Type & Size List of NOK Oil Seals	H1~H-100
I	Leakage Troubleshooting Guide	I-1~I-8
J	Technical Data	J-1~J-32
K	Reference Data	K-1~K-13

A

What Is An Oil Seal?

- What Is An Oil Seal? ————— A-2
- Functional Components of an Oil Seal — A-2

In this Catalog, both the International System of Units(SI) and the conventional system of units are used.

A. WHAT IS AN OIL SEAL?

Simply stated, oil seals are components of a machine that seal lubricants.

Lubricants are used in the friction-producing areas of a machine to ensure smooth movement and long life, and oil seals are used to prevent this lubricant from leaking through “bearing clearances” of the machine. With advances in mechanical engineering, it has become necessary to prevent the leakage of not only lubricants but also water or chemicals, as well as preventing the entry of dust and dirt into the machine. Oil seals are used to perform both functions.

O rings, lip packings, gland packings, and mechanical seals function in similar ways to oil seals, as shown in **Figure 1**. Oil seals are most often used in rotating shaft applications.

The function of an oil seal is easily understood by examining a familiar example: the automobile. **Figure 2** shows oil seals used in automobile engines. In such engines, the reciprocating motion of the pistons is converted into the rotary motion of the crankshaft by the connecting rods. The crankshaft is supported by metal bearings. To lubricate these metal bearings, and other areas where metal and metal slide against each other, engine oil is filled in the oil pan. Since the oil pan is secured to the crank case, “bearing clearance” is needed between the fixed crank case and the rotating crankshaft. An oil seal is a sealing device that prevents the leakage of engine oil from the bearing clearance between the rotating crankshaft and crankcase, or the bearing clearance between a reciprocating shaft and crankcase.

Figure 3 shows oil seals typically used in a geared motor.

Figure 1: Seal Classifications

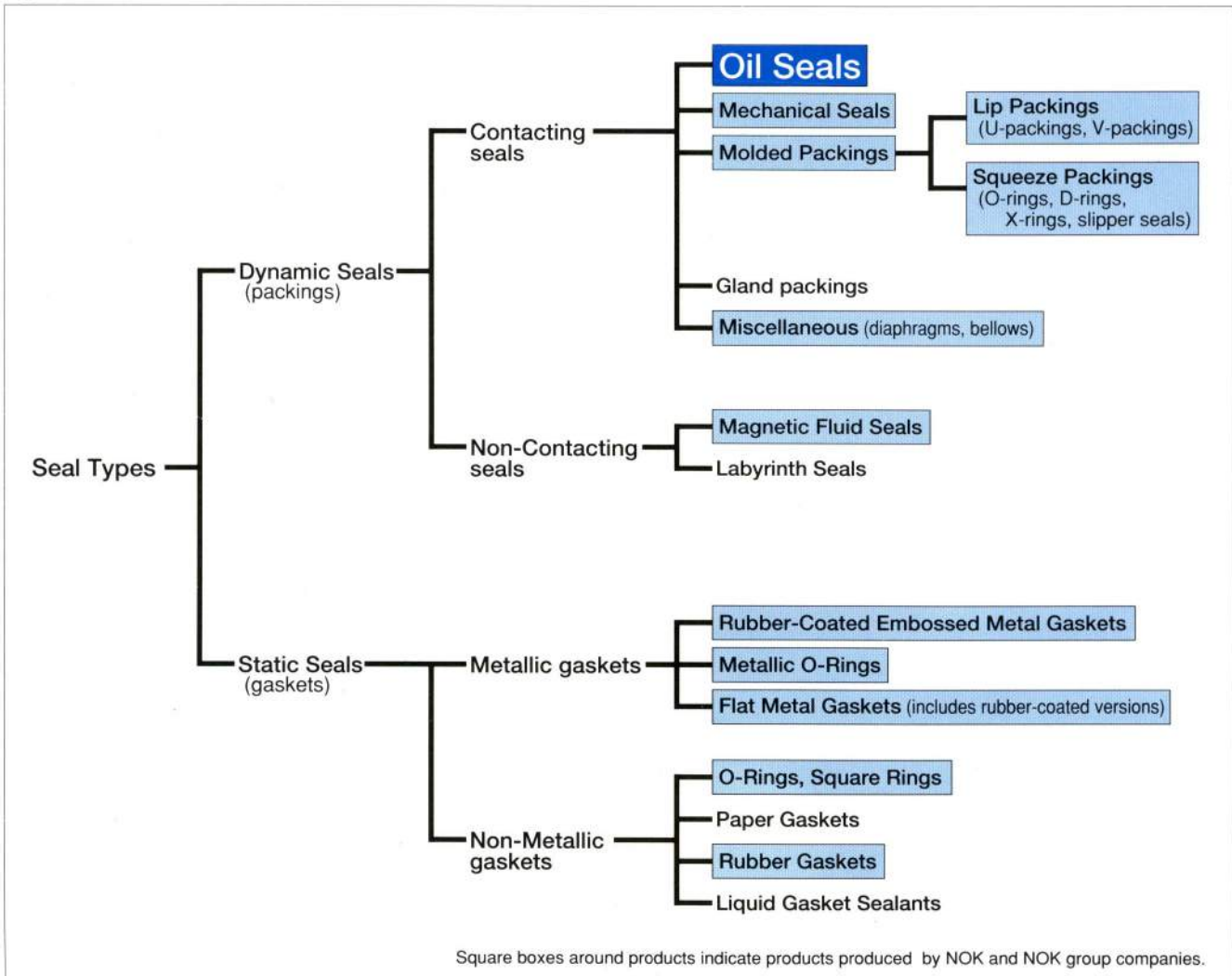

Figure 2: Oil Seals in a Typical Engine Application

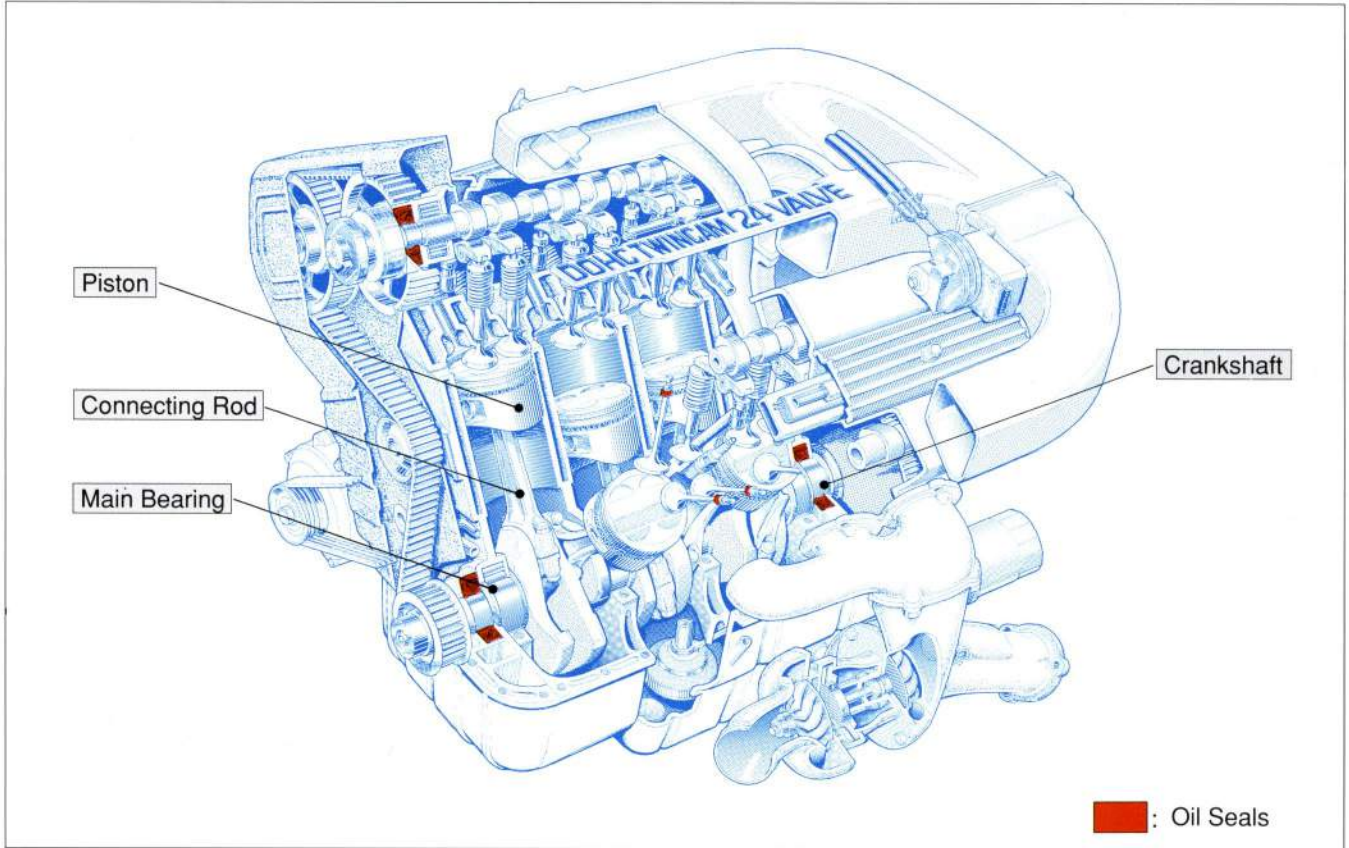
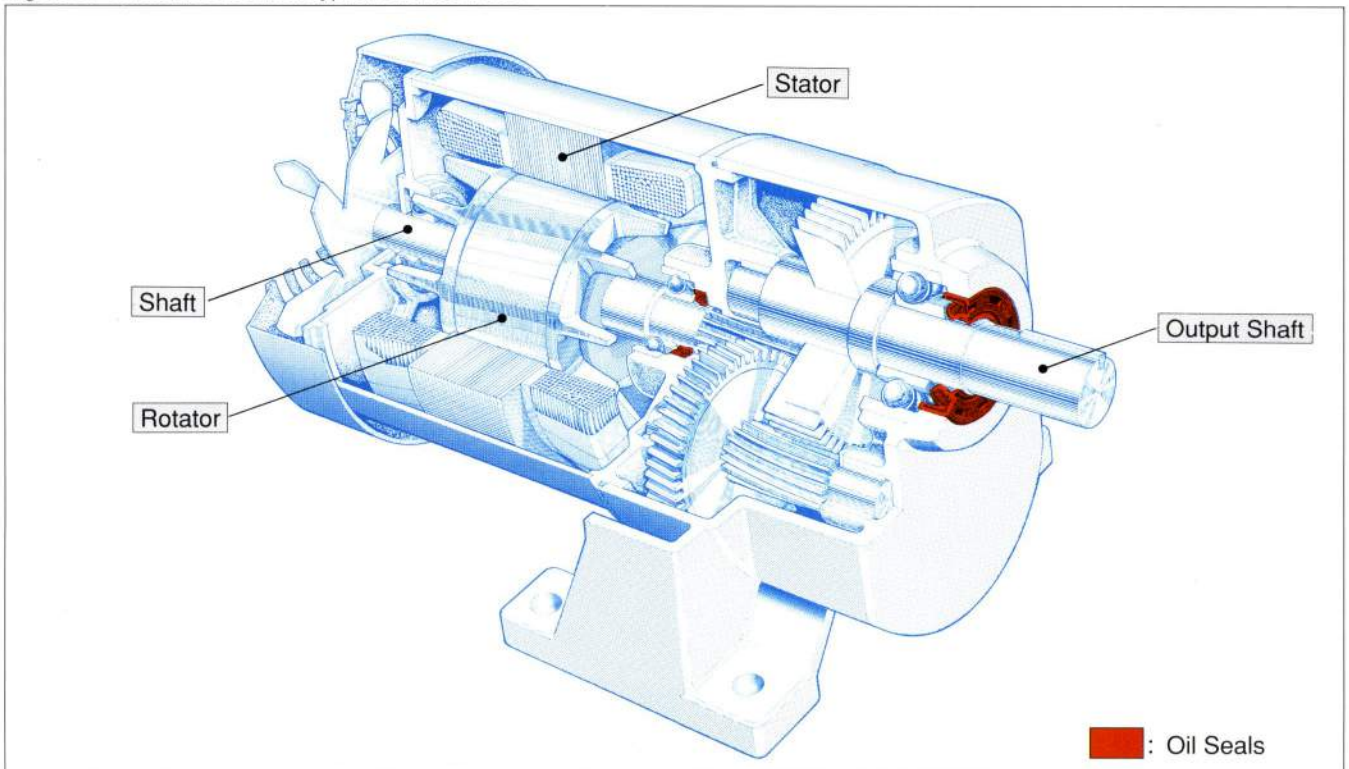

Figure 3: Oil Seals Used in a Typical Geared Motor



Functional Components of An Oil Seal

Figure 4 shows the exterior features of a typical oil seal, and Table 1 describes the function of each part of an oil seal.

Figure 4: Basic Features of An Oil Seal

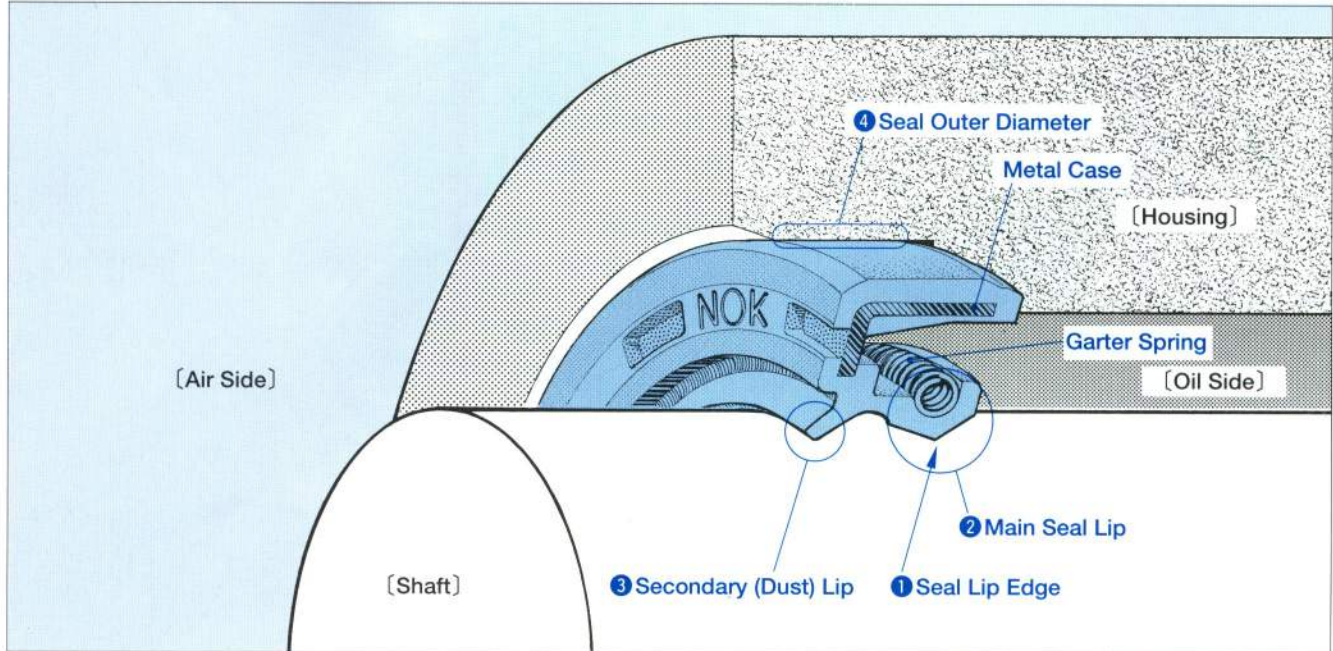

Table 1: Functions of the Various Oil Seal Components

	Part Name	Function	
①	Sealing Edge (shaft contact)	The seal lip has the cross-sectional profile of a wedge, and it presses down onto the shaft surface to seal in fluid.	
②	Lip Area	Seal Lip	The seal lip is made of a flexible elastomer and is designed to maintain stable shaft contact and sealing even with machine vibration and fluid pressure fluctuation. A garter spring adds to the radial load and helps keep the sealing edge in proper contact with the shaft.
③		Dust Lip	A dust lip is an auxiliary spring-less lip, and acts to prevent dirt ingestion.
④	Seal Outer Diameter	The seal OD creates a press-fit to the housing bore, thus retaining the seal and preventing fluid escape. An internal metal case provides a solid backbone for rigidity.	

B

B

The Sealing Mechanism of An Oil Seal

- Lubrication Characteristics ————— B-2
- The Sealing Mechanism ————— B-3

B. THE SEALING MECHANISM OF AN OIL SEAL

How do oil seals actually seal fluid? Due to the continuing efforts of many scholars and researchers, the fundamental sealing mechanism of oil seals has been almost completely illuminated.

NOK announced a sealing theory in 1959, followed by the release of numerous technical publications to the Japan Society of Mechanical Engineers, the Japan Lubricator Makers Association, the Society of Automotive Engineers in the United States (SAE), and the British Hydrodynamics Research Association (BHRA). This theory has earned an excellent reputation among researchers and related industrial societies as being an accurate representation of seal function.

In this chapter, the lubrication factors and sealing mechanism of oil seals are briefly described based on the NOK sealing theory.

■ Lubrication Characteristics

Oil seals used in machines play a major role in sealing fluid, whether the machine is stopped or a shaft is in motion. The frictional force of the lip area is small, and there is little wear.

What lubrication factors of the seal lip's contact edge affect the life of an oil seal? These factors are explained in view of a seal's macroscopic phenomena.

To understand these lubrication factors, it is important to evaluate the seal's frictional properties. For this reason, we placed seals in a test machine, as shown in **Figure 1**, and measured rotational friction forces by turning the shaft under various conditions.

Figure 1: An Oil Seal Installed in a Friction Test

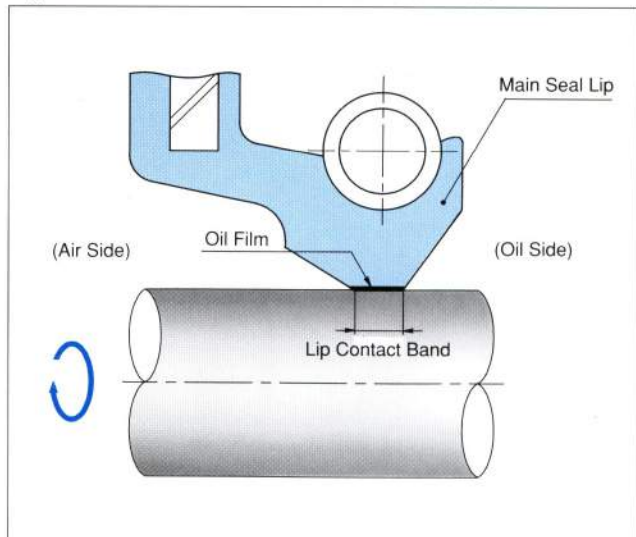
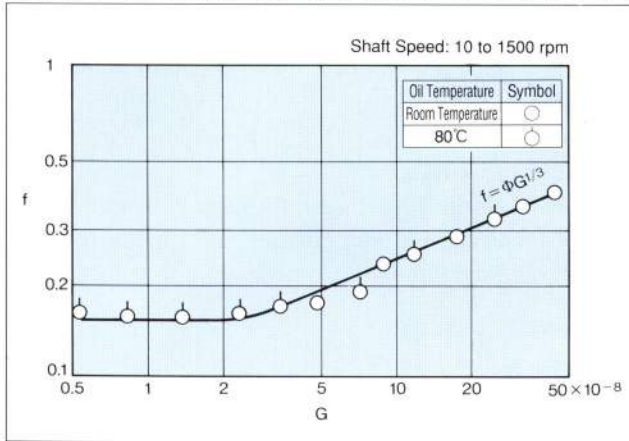

Figure 2 shows the relationship between the non-dimensional duty parameter, G (which is determined by the shape of the oil seal and conditions of use), and the coefficient of friction, f.

Figure 2: Friction Characteristics of Rotating Shaft Oil Seals (f vs. G plot)



Here, the relationship between the coefficient of friction, f, and the non-dimensional duty parameter, G, is given by Expression (1).

$$f = \Phi G^{1/3} \dots \dots (1)$$

Where
 f = Coefficient of Friction
 Φ = An Oil Film Condition Constant
 G = Non-Dimensional Duty Parameter ($= \mu \cdot u \cdot b / Pr$)

Pr = Radial Lip Load on Shaft (N{kgf})
 μ = Oil Viscosity (N·s/cm²{kgf·s/cm²})
 u = Linear Shaft Velocity (cm/s)
 b = Lip-to-Shaft Contact Band Width (cm)

In Figure 2, the positive slope area of the frictional properties has been explained by the lubrication theory. Under such lubrication conditions, the frictional property of seals is governed by the viscosity of the fluid and the shaft's linear velocity (and is also identical to the frictional property of the bearing), and the resultant oil film present underneath the lip edge. In other words, the oil seal's lip and the shaft slide against each other with an intervening film of oil, thus reducing wear.

The Sealing Mechanism

NOK was the first to actually view the sealing mechanism of an oil seal using state-of-the-art image processing technology. Underneath the very narrow lip edge, oil is continually circulated from the air side to the oil side, and then from the oil side to the air side, thus lubricating the sliding surfaces and limiting wear. Theoretical studies have revealed that the sealing mechanism is determined by minor "irregularities" in the sliding surface, and by how the pressure is distributed at the contact area. Here, the sealing mechanism of oil seal is briefly described through macroscopic phenomena.

Lip materials are an important factor in the formation of these special irregularities on the sliding surface of oil seals. Figure 3 shows the textures of the lip surface of two different materials. Lip material A produces a more significant texture on the sliding surface than lip material B.

Figure 3: Lip Surface Textures of Two Materials

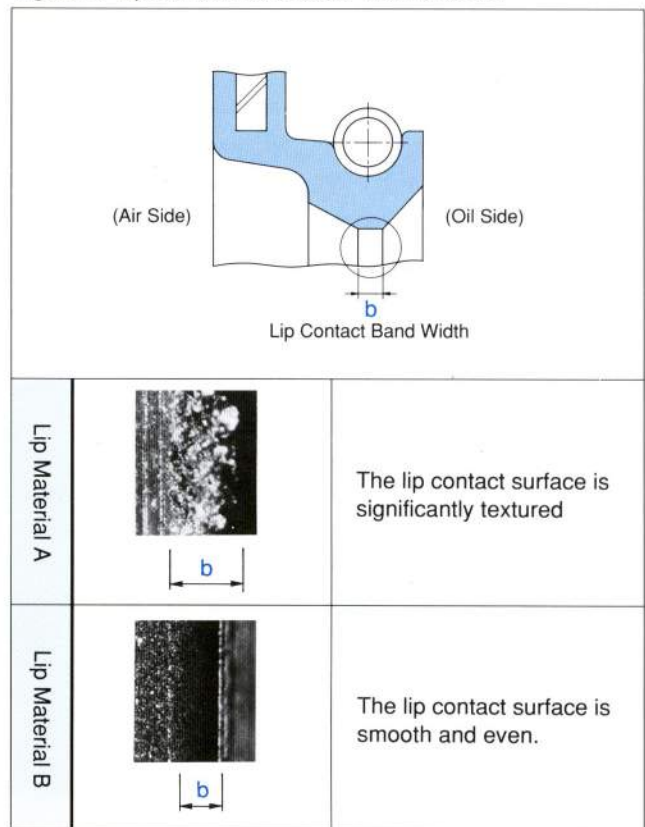

Two oil seals having identical contact pressure distributions were produced using these two lip materials. Since it is generally difficult to measure an air intake rate on an oil seal, the fluid transfer rate is measured using a reversed seal orientation. Thus, oil is now on the "air-side" of the seal, and is transferred under the seal lip via the seal's pumping action.

Scenario (a) in **Figure 4** shows a normal seal installation, i.e., when air is forced toward the oil side. Scenario (b) shows that oil is transferred toward the air side because the oil seal is installed in the reverse direction.

Figure 4: Normal and Reversed Oil Seal Orientation

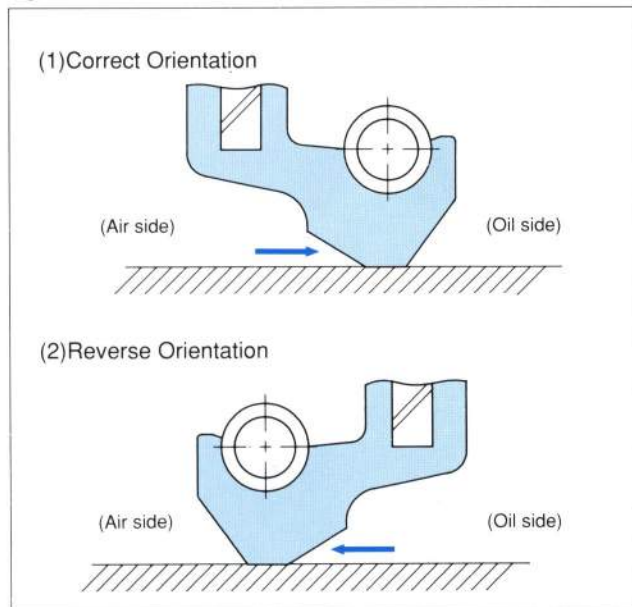

Through the reverse installation (b), the seal's ability to pump oil was quantified by running the shaft and measuring the resultant oil flow rate.

As a result, lip material A was easily identified as more effective in pumping fluid from the air side toward the oil side than lip material B. This was true only when the shape of the lip is not considered (or the same). Even when the lip materials were identical, the pumping ability changes according to the profile of contact pressure distribution; for instance, by changing the shape of the lip.

The two critical elements described above that exert control over the seal's performance, the lubrication characteristics and sealing mechanism, are in a delicately controlled balance through two design factors: the material and shape of the lip. Therefore, in view of these material science considerations, it is necessary to keep in mind that the circulating oil flow must be restricted to within the lip contact area, and that the average film thickness under the seal lip must be controlled.

NOK has put considerable effort into developing lip materials specifically based on the above concepts, and has developed oil seals that can respond to various demanding conditions.

NOK will continue to concentrate on providing products of unsurpassed performance and quality through our ongoing development activities.



NOK Oil Seal Types

■ Standard Oil Seals	—————	C-2
■ General Oil Seals	—————	C-2
Types and Features of NOK's Standard Oil Seals	—————	C-3
Types and Features of NOK's General Oil Seals	—————	C-4
An Introduction to Other Seals	—————	C-6

C. NOK OIL SEAL TYPES

At NOK, we classify oil seals as “standard” oil seals and “general” oil seals.

■ Standard Oil Seals

Standard oil seals are selected on the basis of NOK's extensive track record and understanding of customer needs, and have the following characteristics.

1. Versatility

These oil seals can be used under normal defined operating conditions. (Standard models and standard materials).

See pages E-6 and E-7 for normal operating conditions.

2. Readily Available

These are easily obtained in Japan and throughout the world.

3. Conforms to International and Domestic Codes and Standards

NOK oil seals comply with ISO, JIS, and JASO standards. (Standard types and standard dimensions, shaft outer diameter of 300 mm or less)

For standard oil seals, refer to **Table 1** “Types and Features of NOK's Standard Oil Seals.”

■ General Oil Seals

NOK's general oil seals are designed for specific machines or special conditions and requirements.

For the types of general oil seals for general-purpose use, or with a complete dimensional series, See **Tables 2-1 and 2-2**, “Types and Features of NOK's General Oil Seals.” Certain other types of oil seals are listed in **Table 3**, “An Introduction to Other Types of Seals.”

Please contact us regarding oil seals not listed in this book (i.e., oil seals of standard designs or dimensions but of non-standard materials, or oil seals of standard designs or materials but of non-standard dimensions).

The oil seals listed in this book are not designed to be used in medical equipment. Do not use these oil seals in medical equipment or devices that are used for transplant surgeries or otherwise have contact with bodily fluids or human tissue.

Types and Features of NOK's Standard Oil Seals

Table 1: Types and Features of NOK's Standard Oil Seals

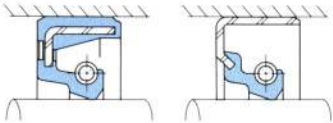
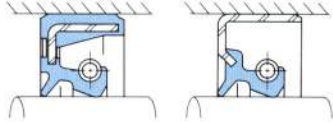
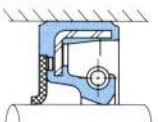
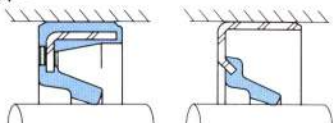
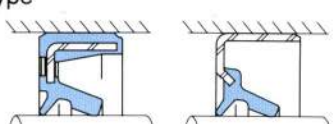
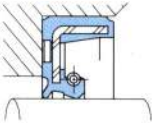
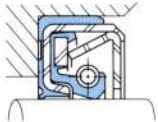
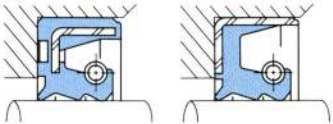
				Page Numbers Showing Dimension Listings				
NOK Type Designation and Cross-Section		Shaft Motion	Primary Uses	Features	Nitrile	Acrylic	Silicone	Fluorocarbon
S type  SC type SB type		Rotating	Oil seal for dust-free applications (Maximum pressure: 0.03MPa{0.3kgf/cm ² })	Oil seal for dust-free use with fluid sealed on one side	H-2	H-15	H-18	H-21
T type  TC type TB type		Rotating	Oil seal for dusty environments (Maximum pressure: 0.03MPa{0.3kgf/cm ² })	Oil seal for very fine dust duty on one side, and fluid sealed on the other side	H-25	H-36	H-39	H-42
New Fabric Seal  TCK type		Rotating	Oil seal for coarse dirt/sand environments (Maximum pressure: 0.03MPa{0.3kgf/cm ² })	The TCK type can be used for the same purposes as the TC and TB types, but it features better dust resistance and air permeability. It produces less friction because the dust lip is made of a NOK-developed special fabric.	H-45	—	—	—
V type  VC type VB type		Rotating	Grease or dust seal (Cannot be used for high-pressure applications)	Used to seal in grease or seal out dust. Can be used in combination with the S-type oil seal.	H-47	—	—	—
K type  KC type KB type		Rotating	Grease seal for dusty environment duty (Cannot be used for high-pressure applications)	Used to seal in grease when there is a small amount of dust on the other side. Two V-type oil seals can also be used.	H-53	—	—	—
TCV type 		Rotating	Oil seal for pressurized duty	Pressure-resistant oil seal with increased lip rigidity. Used for relatively small-diameter and medium-pressure rotating shafts.	H-55	—	—	H-58
TCN type 		Rotating	(For allowable pressures, see pages E-4 and E-5.)	Pressure-resistant oil seal with an auxiliary cage to minimize lip deformation under pressure. Used for relatively large-diameter and high-pressure rotating shafts.	H-55	—	—	H-58
T4 type  TC4 type TB4 type		Reciprocating	Oil seal for reciprocating-shaft applications (For allowable pressures, see page E-7.)	Oil seal designed to minimize lip deformation under reciprocating motion and pressure.	H-60	—	—	—

C

Types and Features of NOK's General Oil Seals

Table 2-1: Types and Features of NOK's General Oil Seals

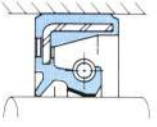
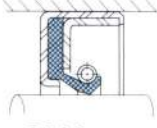
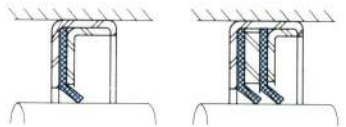
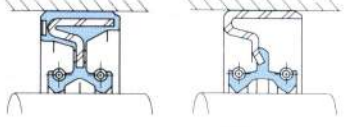
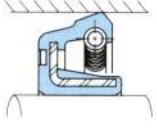
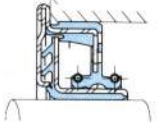
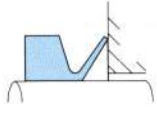
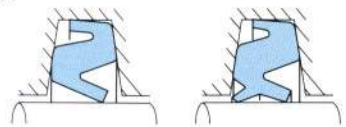
NOK Type Designation and Cross-Section	Shaft Motion	Primary Uses	Features	Page Numbers Showing Dimension Listings
<p>J type (PTFE)</p>  <p>TCJ type</p>	Rotating	Seal for two-cycle engines, torque converters, or washers	Oil seal with a sealing edge of NOK's unique PTFE (ethylene tetrafluoride resin) featuring excellent self-lubricity. Best for use in poor-lubrication areas or low-friction torque use	Nitrile Acrylic H-63
 <p>SA1J type</p>	Rotating	Chemical-resistant seal for high-pressure duty	Oil seal with a sealing edge of NOK's unique PTFE (ethylene tetrafluoride resin) for excellent chemical resistance SA1J type : Garter spring and case are made from SUS (stainless steel) material. Good for sealing chemicals.	H-65
 <p>VAJ type KA3J type</p>	Rotating	Seal for agitator, blower, or food processing applications	VAJ type, KA3J type : Case is made from SUS (stainless steel) material. Good for sealing fine particulates or highly viscous fluids.	H-65
<p>D type</p>  <p>DC type DB type</p>	Rotating	Seal to segregate two types of oils	Oil seal in which two sealing lips are placed in opposing directions; requires less space than mounting two pieces of S-type seals back to back.	H-67
<p>OC type</p> 	Rotating (Housing)	Oil or grease seal with a rotating housing structure	Oil seal in which sealing lip is placed on the outer periphery; best for rotating housing structures.	H-69
<p>QLFY type (Unitized Seal and Shaft Assembly)</p> 	Rotating	Seal for an axle or claw axle of a tractor or power tiller	Oil seal to separate muddy water and oil; used with a cured rubber sleeve as a set. Since the oil seal is integrated with the sleeve, handling is easy.	H-71
<p>VR type (V-shaped End Face Seal)</p> 	Rotating	Grease or dust seal for various machines (Use W type seals to seal water or scale at the roll neck of rolling mills)	Unitized rubber seal: used by press-fitting the inner surface and sliding seal axially to contact the end face of the housing.	H-73
<p>Z type</p>  <p>ZF type ZT type</p>	Rotating	Grease seal for the plummer block of an anti-friction bearing	Used by mounting the oil seal into the trapezoidal groove of the plummer block of an anti-friction bearing. Use ZT type for a low dust quantities.	H-77



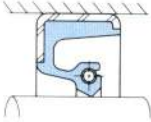
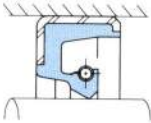
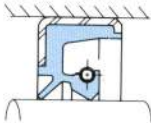
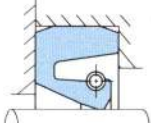
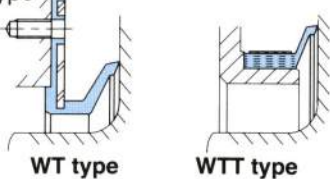
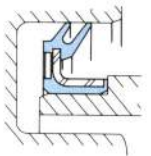
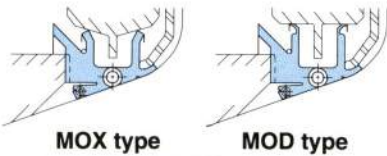
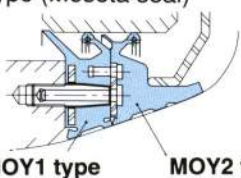

Types and Features of NOK's General Oil Seals

Table 2-2: Types and Features of NOK's General Oil Seals

NOK Type Designation and Cross-Section	Shaft Motion	Primary Uses	Features	Page Numbers Showing Dimension Listings
SBB type 	Rotating	Oil or water seal for dust-free and large-diameter shaft use (Shaft diameter: >300mm)	Oil seal for dust-free use with fluid sealed on one side. Better under high-speed rotation than the large-diameter SB type. A spacer-attached model is also available.	H-81
Large-Diameter SB type 	Rotating	Oil or water seal for dust-free and large-diameter shaft use (Shaft diameter: >300mm)	Oil seal for dust-free use with fluid sealed on one side. A spacer-attached model is also available.	H-81
Large-Diameter TB type 	Rotating	Oil or water seal for dusty-area and large-diameter shaft use (Shaft diameter: > 300mm)	Oil seal for light duty dust (dirt or sand) on one side and fluid sealed on the other side	H-86
MG type 	Rotating	Oil or water seal. Used for areas where seal cannot be inserted from the shaft end	Used when a machine cannot be assembled without cutting the oil seal. A hook joint spring is used to mount the sealing lip, and the outer surface is sealed by pressing down against the contact surface of the shaft. Since one part of the seal is cut, the sealing performance is inferior to that of S-type seals.	H-88
W type 	Rotating	Water or scale seal for the roll neck of rolling mills	Oil seal to prevent the entry of water or scale by sliding the sealing lip against the shaft (flange) end face. The WT type is mounted by bolting, and the WTT type is mounted by tightening the collar band.	H-92
OKC3 type 	Rotating	Water or scale seal for the roll neck of rolling mills	Water or scale seal. Used by pressing the inner diameter surface of the seal onto the housing and sliding the outer sealing lip against the inner surface of the shaft (flange)	H-95
MO type (Morgoil seal) 	Rotating	Two-liquid oil and water seal for the roll neck of rolling mills	Roll neck seal for film bearing (Morgoil). Seals oil inside and water outside by fixing the inner surface to the shaft (roll) and sliding two sealing lips on the housing side against the housing.	H-98
MOY type (Meseta seal) 	Rotating	Two-liquid oil and water seal for the roll neck of rolling mills	Roll neck seal for film bearing (Mitsubishi Bearing). The inner surface of the seal is fixed to the shaft (roll) and outside lip on the housing side slides. Use MOY1 type (oil side) and MOY2 (water side) as a set. Can be changed individually	H-99

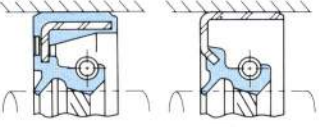
An Introduction to Other Oil Seals

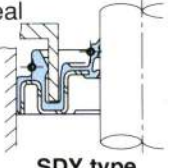
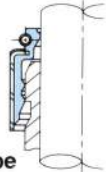
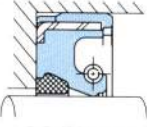
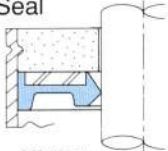
Table 3: An Introduction to Other Oil Seals

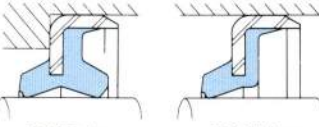
NOK Type Designation and Cross-Section	Shaft Motion	Primary Uses	Features
<p>Helical seal</p>  <p style="text-align: center;">HTC type HTB type</p>	Rotating	Oil seal for engines or transmissions	Oil seal where the entire sealing lip edge has a molded-in helical feature on the air side. This “screw thread” acts to return the fluid trying to escape outside through the sealing lip back inside using a screw-pump action.
<p>Super Package Seal</p>  <p style="text-align: center;">CSK type</p>	Rotating	Seals splashing oil in engines	Oil seal where the end face seal and the slinger are molded, thereby improving installation reliability. Best under high-speed rotation
<p>Severe-Dust Seal</p>  <p style="text-align: center;">TC6Y type</p>	Rotating	Seals areas where muddy water splashes on tractor or power tiller	Oil seal where the two dust-side lips of a T-type oil seal are used to improve dust resistance
<p>Washer Seal</p>  <p style="text-align: center;">SDY type</p>	Rotating	Seal for dewatering shaft of a washer	Oil seal designed specifically for washers. Seals water in two places (dewatering shaft and inside the washing tub) of fully-automatic washers
<p>Valve Stem Seal</p>  <p style="text-align: center;">VSB type</p>	Reciprocating	Seal for engine intake and exhaust valve stems	Oil seal to maintain a proper film of oil between the valve stem and valve guide of an engine
<p>High Pressure Seal</p>  <p style="text-align: center;">SCJY type</p>	Reciprocating	Seal for reciprocating rods with relatively large dynamic shaft misalignment	Oil seal for reciprocating motion. Pressure resistance is improved by an assembling nylon backup ring. Compared to U-type packing, this model is more suitable when a rod's dynamic misalignment is relatively large.
<p>Gas Spring Seal</p>  <p style="text-align: center;">XKD type</p>	Reciprocating	Seal for gas-spring rods of business machines, furniture, or medical equipment	Oil seal for reciprocating rods of high-pressure gas cylinders, with good sealing performance and low friction.
<p>Control Valve Seal</p>  <p style="text-align: center;">SVY type</p>	Reciprocating	Oil seal for hydraulic control valves of construction machinery	Sealing performance is better and friction is lower than a rubber-only seal. The seal is fixed by clamping the outer flange.
<p>Dust Seal</p>  <p style="text-align: center;">DKB type DKH type</p>	Reciprocating	Dust seal for hydraulic cylinders	Seal to prevent the entry of dust. The DKB seals oil better than the DKH type.

D

NOK Oil Seal Materials

■ Rubber Materials	—————	D-2
1. Rubber Types	—————	D-2
2. Types and Primary Uses of NOK Lip Materials	—	D-5
■ Garter Springs and Metal Cases	—————	D-7

D

D. NOK OIL SEAL MATERIALS

An oil seal is constructed of rubber (seal lips and outer surfaces), a garter spring and an internal case. The following materials are used for each part.

Rubber

1. Rubber Types

Table 1 shows the types and features of the various rubber materials used in oil seals, and Table 2 shows their resistance to oils and chemicals.

When selecting a lip material for a seal application, please refer to Table 3 "Types and Primary Uses of NOK's Lip Materials".

Table 1: Rubber Types and Characteristics Used in NOK's Oil Seals

Item Type	Oil Resistance <small>See Note(1)</small>	Alkali Resistance	Acid Resistance	Water Resistance	Weather Resistance	Abrasion Resistance	Temperature Range (°C) <small>See Note(2)</small>		Features
							Lower Limit	Upper Limit	
Nitrile Rubber (NBR)	⊙	○	○	○	△	⊙	-40	+125	This material is most often used in oil seals due to its excellent resistance to mineral oil and abrasion; however, oil seals made of this rubber cannot be used for polar solvents, such as ketone or ester.
Hydrogenated Nitrile Rubber (HNBR)	⊙	○	○	○	○	⊙	-25	+140	This rubber has similar characteristics to nitrile rubber for oil seal use, but has better resistance to heat, oils, and weather than standard nitrile rubber.
Acrylic Rubber (ACM)	⊙	×	△	△	⊙	⊙	-25	+150	This rubber has the same good oil resistance as nitrile rubber, and has good heat resistance similar to silicone rubber. Weather resistance is also excellent. Resistance to alkalis or water is inferior to that of other types of rubber.
Silicone Rubber (VMQ)	○	×	△	△	⊙	○	-60	+225	This rubber is highly resistant to heat, cold, and weather, but its resistance to alkalis or water is inferior to that of other types of rubber.
Fluorocarbon Rubber (FKM)	⊙	△	○	○	⊙	⊙	-20	+250	This rubber has heat resistance surpassing that of silicone. It also has excellent resistance to oils and chemicals. This material is the best rubber for oil seals due to its well-balanced characteristics.
Ethylene-Propylene Rubber (EPDM)	×	○	○	⊙	⊙	○	-40	+125	This rubber has excellent resistance to water, polar solvents, inorganic chemicals, and weather. Its oil resistance is inferior.
Styrene-Butadiene Rubber (SBR)	×	○	△	○	△	⊙	-45	+100	This rubber has excellent resistance to polar solvents and water. Its oil resistance is inferior.
Tetrafluoroethylene Resin (PTFE)	⊙	⊙	⊙	⊙	⊙	⊙	-65	+260	This material has the maximum degree of resistance to heat, cold, chemicals, and weather, and a lower coefficient of friction. It is not as elastic as rubber.
Fabric	⊙	⊙	⊙	⊙	⊙	⊙	-50	+160	Since the primary material is synthetic fiber, resistance to heat and fraying is superior to that of conventional felt.

Remarks : ⊙ Resistant
 ○ Resistant Except in Special Cases
 △ Not Resistant Except in Special Cases
 × Not Resistant

Note(1): Oil resistance does not include resistance to phosphoric ester or water-glycol fire resistant fluid.

Note(2): Temperatures shown in the temperature range are based on the following codes.

Upper Temperature Limits

Is defined as the highest temperature that allows a maximum tensile strength change of 630%, an elongation change of -50%, or a hardness change of 615 points after the completion of a 70-hour air-oven aging test.

[This maximum temperature applies to the heat-resistant reference temperature for material evaluation as defined in ASTM (The American Society for Testing and Materials) D2000 Line Call-outs.]

Lower Temperature Limits

The TR10 value is used to determine the low temperature limits.

TR is an abbreviation for “temperature-retraction,” as defined in ASTM D1329. TR represents the recovery properties during low temperatures, and nearly equals the recovery properties of rubber-like elasticity.

The TR10 value indicates the temperature when a given strain is recovered by 10%. Figure 1 shows a typical TR curve.

Figure 1: TR Diagram

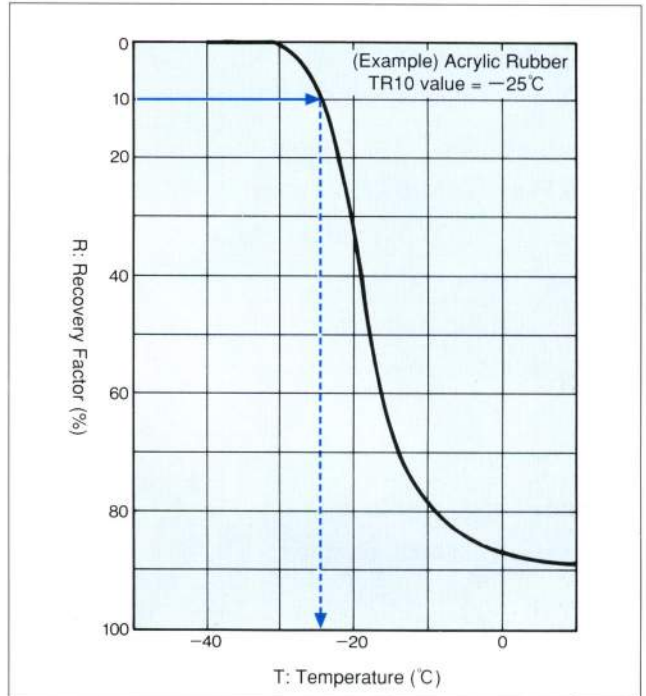

Cold Temperature Resistance of Oil Seals

The cold temperature resistance of an oil seal is determined by a complicated interaction of various elements, such as the characteristics of the lip material and fluids to be sealed, shaft run-out, and start up speed.

The lip of the oil seal flexes only a few percent when the run-out of the shaft is only a few percent.

Therefore, NOK uses the TR10 value for lip materials as an index of the lowest allowable temperature. Under actual use conditions, even if the temperature is lower than the TR10 value, the temperature at the sealing edge increases due to friction immediately after start-up, allowing rubber-like elasticity to be recovered and thus retain good sealing performance.

However, even if the temperature is higher than the TR10 value, leakage may occur if the shaft run-out is too severe for the lip to follow properly. Thus, it is dangerous to determine the allowable temperature of oil seals solely on the TR10 value. These and other factors mentioned should be taken into consideration.

Table 2: Oil and Chemical Compatibility of Various Rubber Materials

Rubber Type		Nitrile Rubber	Hydrogenated Nitrile Rubber	Acrylic Rubber	Silicone Rubber	Fluorocarbon Rubber	Ethylene-Propylene Rubber	Styrene-Butadiene Rubber	Tetrafluoroethylene resin
Engine Oil	SEA #30	○	○	○	○	○	×	×	○
	SEA 10W-#30	○	○	○	○	○	×	×	○
Gear Oil	Automotive	○	○	○	△	○	×	×	○
	Class 2 industrial use (extreme-pressure), synthetic base	○	○	△	△	○	△	△	○
Torque Converter Oil Automatic Transmission Fluid		○	○	○	×	○	×	×	○
Brake Fluid	DOT 3 (glycol base)	△	×	×	○	×	○	○	○
	DOT 5 (glycol base)	△	×	×	○	×	○	○	○
	DOT 5 (silicone base)	○	○	○	×	○	×	○	○
Class 2 Turbine Oil		○	○	○	△	○	×	×	○
Machine Oil (No.2 spindle oil)		○	○	○	×	○	×	×	○
Hydraulic Fluid (mineral oil base)		○	○	○	△	○	×	×	○
Fire Resistant Fluid	Phosphate Base	×	×	×	○	△	×	×	○
	Water + Glycol Base	○	○	×	△	△	×	×	○
Cutting Fluid		○	○	△	△	○	×	×	○
Grease	Mineral Oil Base	○	○	○	○	○	×	×	○
	Silicone Base	○	○	○	×	○	×	○	○
	Fluorine Base	○	○	○	○	△	×	×	○
Refrigerants	R12 + Paraffin Base	○	○	×	×	×	×	×	○
	R134a + Glycol Base	△	○	×	×	×	○	×	○
Gasoline		△	○	×	×	○	×	×	○
Light Oil, Kerosene		△	○	×	×	○	×	×	○
Heavy Oil		○	○	△	×	○	×	×	○
Anti-Freeze Solution (ethylene glycol base)		○	○	×	△	×	○	○	○
Water, Warm Water		○	○	×	○	○	○	○	○
Sea Water		○	○	×	×	○	○	○	○
Water, Steam		×	○	×	×	×	○	△	○
10% Hydrochloric Acid Solution		○	○	○	○	○	○	○	○
30% Sulfuric Acid Solution		△	△	△	×	△	○	△	○
10% Nitric Acid Solution		×	△	×	×	△	○	×	○
40% Sodium Hydroxide Solution		○	○	×	×	×	○	○	○
Benzene		×	×	×	×	×	×	×	○
Ethyl Alcohol		○	○	×	○	○	○	○	○
Methyl Ethyl Ketone		×	×	×	△	×	×	×	○

Remarks : ○ Resistant
 ○ Resistant Except in Special Cases
 △ Not Resistant Except in Special Cases
 × Not resistant

2. Types and Primary Uses of NOK Lip Materials

Various NOK seals using the types of rubber introduced in Table 1 are available. Table 3 shows the types and primary uses of typical NOK lip materials.

Each lip material is designed for outstanding sealing performance and the best balance between each property inherent to a raw material.

To obtain well-balanced lip materials, it is vital to select

proper raw materials or compounding chemicals, and apply appropriate compounding techniques. At NOK, we develop high-quality raw materials and compounding chemicals, combined with research about the effect of each material on the sealing function, in order to create an optimal material for oil seals.

Furthermore, we apply the results of this research and technology to manufacture better lip materials.

Table 3: Types and Primary Uses of Typical NOK Lip Materials

NOK Lip Material		Hardness (Durometer A)	Temperature Range (°C)	Primary Uses	Fluid to be Sealed			
Rubber Type	Material Symbol (Color)				Oil	Mineral Water	Muddy Water	Grease
Nitrile Rubber (NBR)	A727 (Black)	70	-30~+120	Standard material (for rotating shafts)	○			○
	A941 (Black)	80	-25~+100	Standard material for medium-to-large diameter (150 mm or larger) shafts (for rotating shafts)	○			○
	A795 (Black)	80	-11~+100	Standard material (for reciprocating shafts and high pressure), fuel oil resistance	○			○
	A275 (Black)	70	-40~+100	Cold and weather resistance (for rotating shafts)	○			○
	A427 (Black)	80	-40~+100	Cold resistance (for reciprocating shafts)	○	○		○
	A571 (Black)	75	-25~+100	Abrasion resistance from muddy water (for rotating shafts)			○	○
	A368 (Black)	75	-20~+100	Compliance with the Food Sanitation Law (for rotating shafts)				○
	A989 (Black)	70	-20~+100	Special material (MO type)	○	○		○
	A103 (Black)	70	-22~+100	Water resistance (for rotating shafts)			○	
				Special material (TCJ type)	○			○
	A104 (Black)	80	-21~+100	Special material (MG type)	○	○		○
A134 (Black)	60	-20~+100	Special material (VR type)			○	○	
Hydrogenated Nitrile Rubber (HNBR)	G418 (Black)	75	-25~+130	Special material (for reciprocating shafts, MOY type)	○			
Acrylic Rubber (ACM)	T303 (Black)	80	-15~+150	Standard material (for rotating shafts)	○			○
	T599 (Black)	80	-25~+140	Cold resistance (for rotating shafts)	○			○
	T302 (Black)	70	-15~+150	Special material (TCJ type)	○			○
Silicone Rubber (VMQ)	S728 (Black)	80	-45~+170	Standard material (for rotating shafts)	○			
	S817 (White)	75	-45~+170	Compliance with the Food Sanitation Law (for rotating shafts)				○
Fluorocarbon Rubber (FKM)	F585 (Brown)	75	-15~+200	Standard material (for rotating shafts)	○			○
	F975 (Brown)	80	-15~+200	Special material (for reciprocating shafts)	○			○
	F548 (Black)	85	-16~+200	Pressure resistance (for rotating shafts)	○			○
	F129 (Black)	70	-15~+200	Special material (VR type)				○
Tetrafluoroethylene Resin (PTFE)	31BF (Black)	Durometer D 65	(-50)~+220	Special material (J type), resistance to chemicals and heat, low friction	○			○
	40WF (White)			Compliance with the Food Sanitation Law (for rotating shafts)				○
Fabric	31FH (Black)	—	(-50)~+160	Material for secondary/dust lips, air permeability				—

Note(1): Ethylene-propylene rubber and styrene-butadiene rubber (not listed in Table 3) are also available for special uses.

Note(2): Temperatures listed are based on the following criteria.
Upper Limit : A yardstick for temperatures that can be used relative to the function of oil seals.
Lower Limit : The TR10 value for each lip material is used.

Note(3): For details on resistance of various lip materials to sealing fluids, see Chapter 7 (page J-7)

The various degrees of resistances and the temperature ranges shown in **Tables 2 and 3** are for informational purposes only. Users should carefully read Chapter E “NOK Oil Seal Application Guide” and Chapter J “Oil and Chemical Resistance of NOK Lip Materials.”

To safeguard the function of the oil seal, careful attention is required regarding the application's operating temperatures, as temperature directly affects the both the seal and the fluids.

Rubber is sensitive to changes in temperature. A change in rubber at higher temperatures produces a chemical change in which elasticity is lost because the high polymers of the rubber are excessively cut or bonded due to heat, oils, chemicals or ozone. Therefore, the proper working temperature can be determined by the correlation between temperature and time. For example, relatively high temperatures may be used for short periods of time. Conversely, lower temperatures may be used for longer periods of time.

D Another change in rubber properties at very low temperature is hardening caused by less active polymers. This reversible phenomena is dependent on temperature only. The normal rubber-like elasticity of an oil seal is recovered when the ambient temperatures return to normal.

Garter Springs and Metal Cases

NOK's garter springs and cases are made from the materials shown in Table 4.

Standard materials for garter springs and cases are

used in oil seals for lubricant or grease sealing. Special materials are used for sealing water, corrosive chemicals, or gas.

Table 4: Types and Applications of Garter Spring and Metal Case Materials

Spring and metal case materials Fluid to be Sealed	Garter spring			Metal Case		
	Standard materials	Special materials		Standard materials	Special materials	
	JIS G 3521 SW (hard-drawn copper wire) JIS G 3522 SWP (piano wire)	JIS G 4309 SUS (stainless steel wire)		JIS G 3141 SPCC (cold-rolled steel sheet and strip) JIS G 3131 SPHC (hot-rolled steel sheet and strip)	JIS G 4305 SUS (cold-rolled stainless steel sheet) JIS G 4307 SUS (cold-rolled stainless steel strip)	
		304	316		304	316
Lubricants, grease	○	○	○	○	○	○
Water	×	○	○	×	○	○
Steam	×	○	○	×	○	○
Sea water	×	×	○	×	×	○
Acids	×	×	○	×	×	○
Alkalis	×	○	○	×	○	○

Remarks : ○ Can be used
× Do not use

The Function of a Garter Spring

A garter spring increases and maintains the pressure of the sealing lip on the shaft. Since garter springs used in oil seal have the characteristics shown in Figure 2, it is possible to obtain the load necessary for good sealing with little elongation. As shown in Figure 2, even if a garter spring is elongated to some extent, the spring load does not change significantly. The length of a garter spring in an oil seal is determined by considering the proper amount of elongation required to ensure that it can function properly within the working range defined in Fig. 2.

Figure 2: Characteristics of Garter Springs Used in Oil Seals

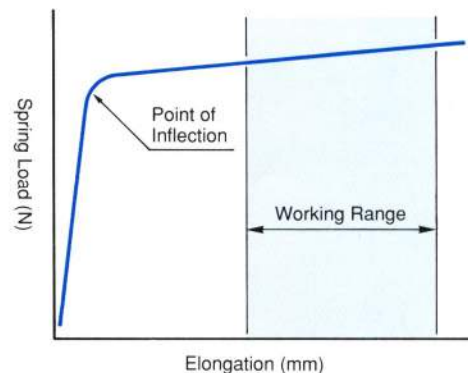

The Function of a Metal Case

Cases plays an important role in maintaining the retention strength between the seal and the housing bore, thus keeping the seal lip at its intended position.

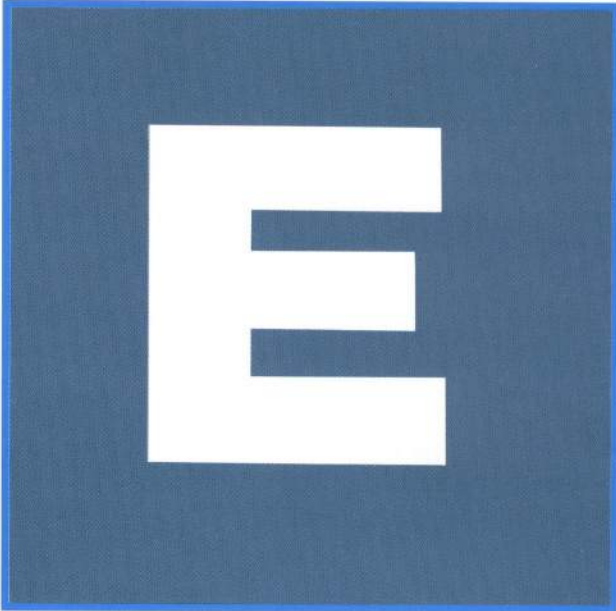

NOK Oil Seal Application Guide

- NOK Oil Seal Application Guide ————— E-2
 - 1. The Selection Process ————— E-2
 - 2. Allowable Operating Temperature Range — E-7



To ensure optimal performance, it is necessary to select the appropriate oil seal type and material for the actual operating conditions.

This chapter describes selection process and permissible temperature ranges for each type of oil seal listed in this catalog.

If the oil seal you need (type, material, or dimensions) is not listed in this catalog, please contact us regarding customized products.

■ Selection Process

Use the following steps to select your oil seal.

1. Select the Seal Type

Select the proper seal type per **Figure 1** “Flowchart for Seal Type Selection” on pages E-4 and E-5.

2. Select the Seal Lip Material

Since lip materials for catalog products should be selected according to the appropriate conditions for each oil seal type (see **Table 1** “Lip Materials by Oil Seal Type”), please refer to **Table 3** “A Guide to Permissible Working Range of Standard Oil Seals” (on pages E-6 and E-7) and **Table 4** “A Guide to Select the oil seal type in accordance with **Fig. 1** “Flowchart for Seal Type Selection” on pages E4 and E5.

“A Guide to the Allowable Operating Conditions of General Oil Seals” (pages E8 to E11), as well as Chapter J “Oil and Chemical Resistance Ratings of NOK Lip Materials.”

3. Select the Metallic Materials

The metallic materials for garter springs and cases should be selected by the appropriate oil seal type, same as lip materials. **Table 2** shows the appropriate metallic materials by oil seal type. Please refer to **Table 4** “Types and Applications of Garter Spring and Case Materials (page D-7).

4. Select Seal Dimensions

Check whether the dimensions of the oil seal you want matches the shaft diameter, housing diameter, and width of the relevant area by referring to Chapter H “Type and Size List of NOK Seals.”

Please consult us before using NOK oil seals in aircraft or nuclear power equipment. The oil seals listed in this catalog are not designed nor manufactured to be used in medical equipment, and should not be used in medical equipment used for transplant surgeries or in applications that come into contact with bodily fluids or living tissue.

Materials for the oil seal lips, garter springs, and cases described in this catalog must be selected according to the applicable usage conditions for each oil seal type.

Table 1: Lip Materials by Oil Seal Type

NOK Type Designation	Shaft Diameter mm	Lip Materials																
		A727	A103	A104	A795	A134	A941	A571	A989	G418	T302	T303	S728	F585	F548	F129	31BF	31FH
S, T	Less than 150	○										○	○	○				
	Greater than 150						○					○	○	○				
TCK		○																○
V, K	Less than 150	○																
	Greater than 150						○											
TCV					○										○			
TCN					○										○			
T4					○													
TCJ			○								○							○
SA1, VAJ, KA3J																		○
D		○																
OC		○																
QLFY								○										
VR						○											○	
Z			○															
SBB							○											
MG			○	○														
W			○															
OKC3			○															
MO										○								
MOY											○							

Table 2: Metallic Materials by Oil Seal Type

NOK Type Designation	All types except those listed on the right	SA1J, VAJ, KA3J
Garter Spring	JIS G3521 SW JIS G3522 SWP	JIS G4309 SUS304
Metal Case	JIS G3141 SPCC JIS G3131 SPHC	JIS G4305 SUS304 JIS G4307 SUS304

Flowchart for Seal Type Selection

Figure 1: Flowchart for Seal Type Selection (For the features of each oil seal type, refer to pages C-3, C-4, and C-5.)

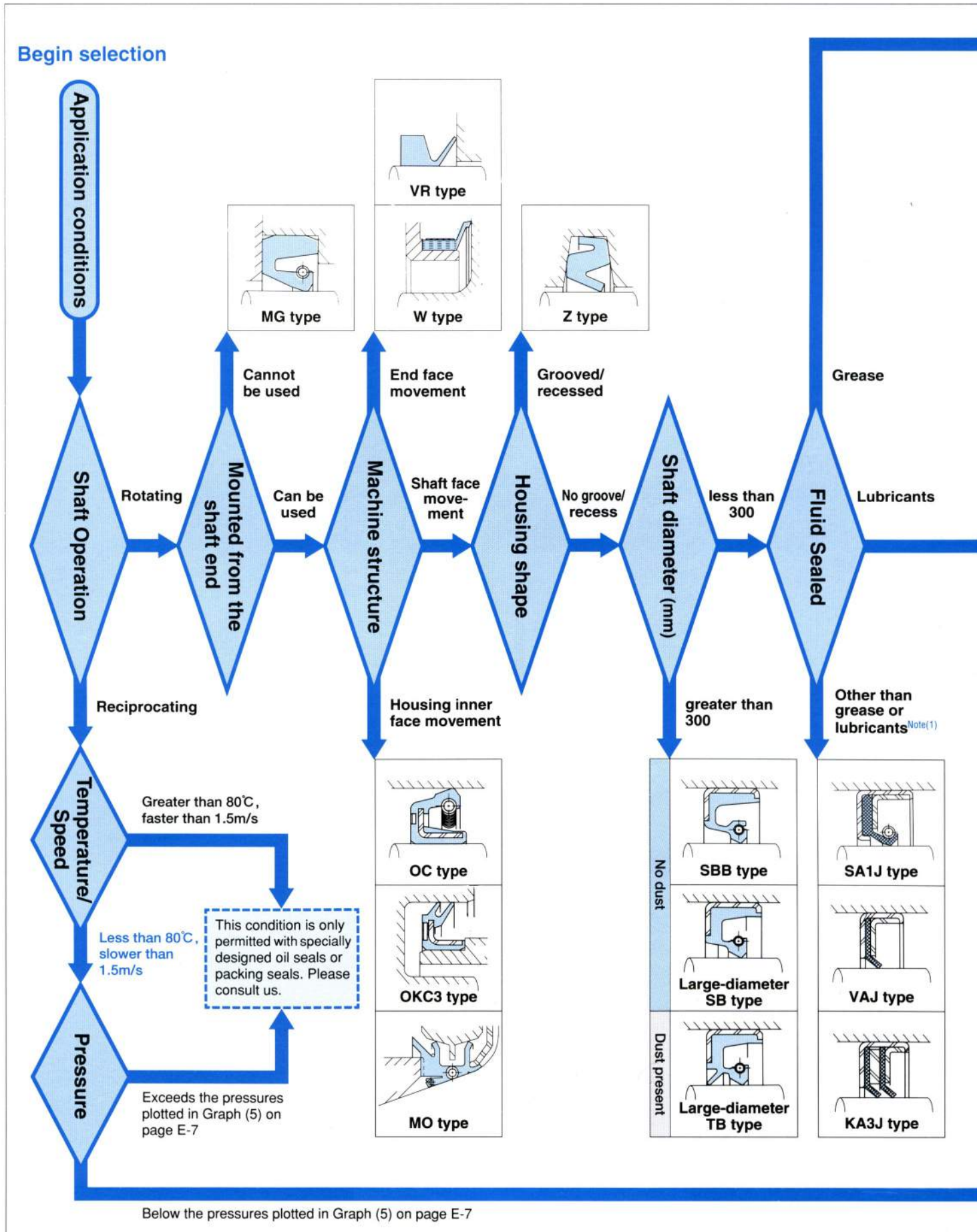

- Note(1): You may select any oil seal type, other than SA1J, VAJ and KA3J, depending on the type of fluid sealed (brake oil, gasoline, kerosene, light oil, heavy oil, cutting oil, or water or chemical fluid). Please consult us.
- Note(2): When the housing material is a light alloy or resin having a large coefficient of thermal expansion, select a seal with a rubber exterior. For other housings, you may select either a rubber or metal exterior design.
- Note(3): When you cannot make a selection from this flowchart for other application conditions (such as vacuum or negative pressure), please consult us.

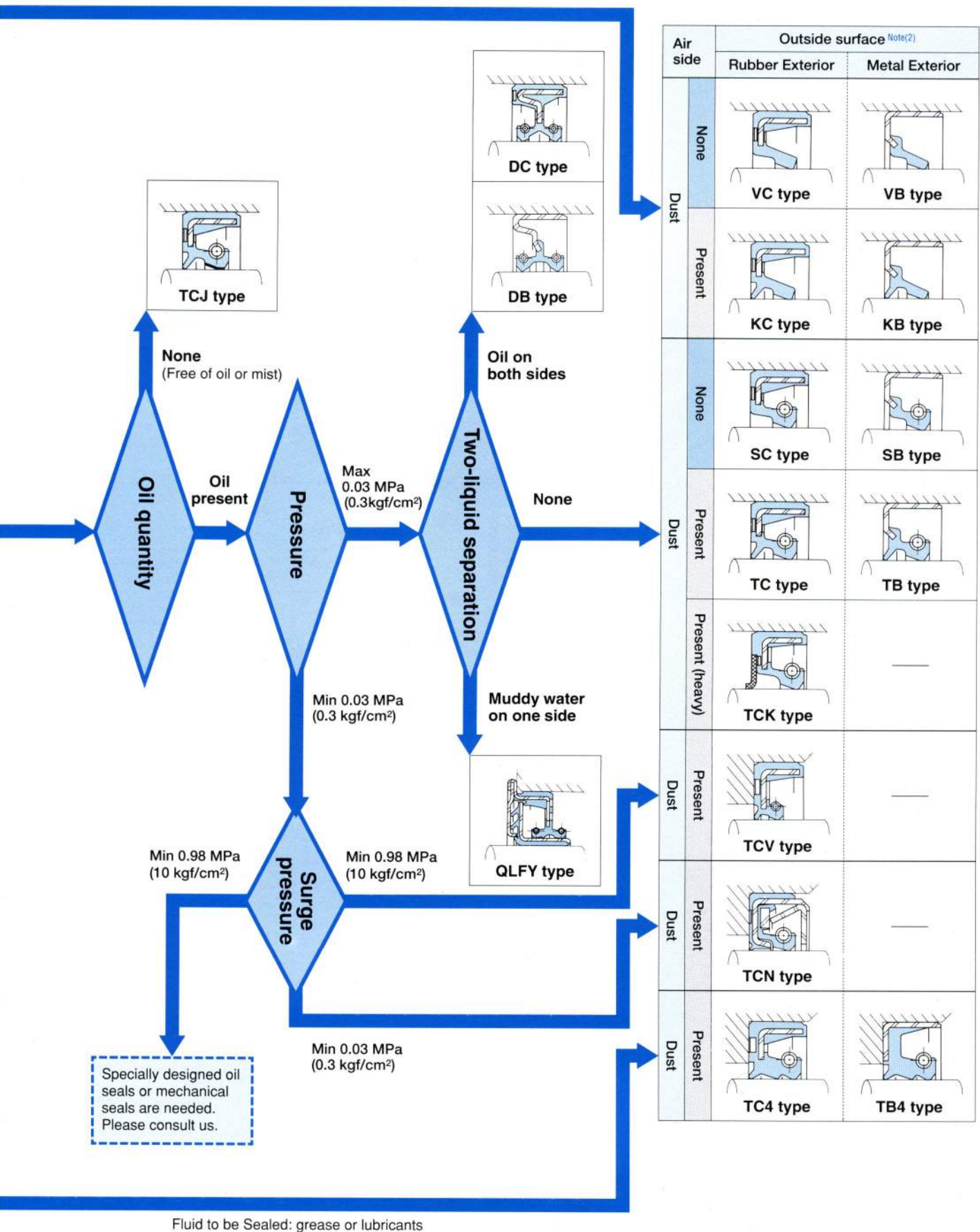

E

A Guide to Allowable Operating Conditions

Note (1): The working ranges listed are a general guide based on the general seal shape and material, and may vary with actual working environments or seal designs. For use at higher linear shaft velocities, higher pressures, or higher/lower temperature regions than shown here, please consult us.

Table 3: A Guide to Allowable Operating Conditions of Standard Oil Seals

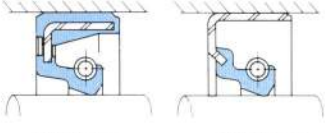
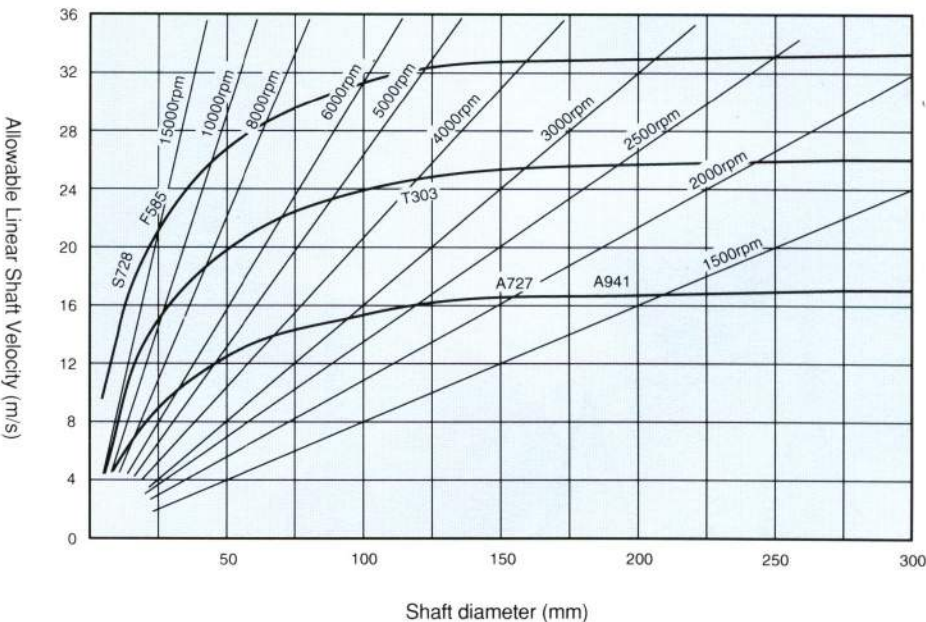
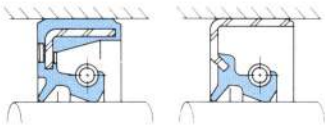
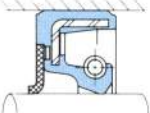
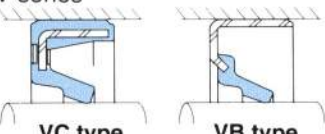
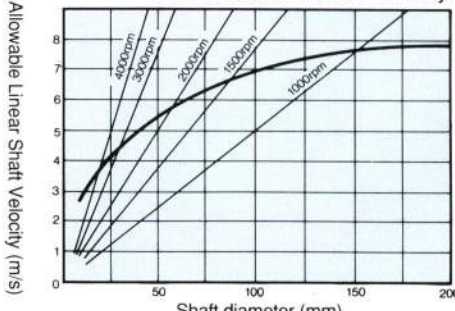
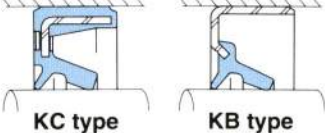
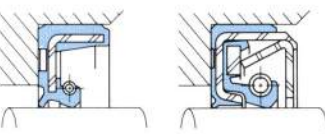
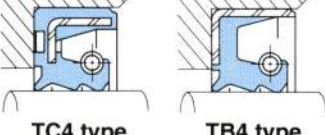
NOK Seal Type	Item	Linear Shaft Velocity (m/s)
S series  <p style="text-align: center;">SC type SB type</p>		<p>Use a linear shaft velocity within the permissible range plotted in Graph (1).</p> <p style="text-align: center;">Graph (1): Shaft Diameter vs. Maximum Allowable Linear Shaft Velocity</p> 
T series  <p style="text-align: center;">TC type TB type</p>		
New fabric seal  <p style="text-align: center;">TCK type</p>		
V series  <p style="text-align: center;">VC type VB type</p>		<p>Use a linear shaft velocity within the permissible range plotted in Graph (2).</p> <p style="text-align: center;">Graph (2): Shaft Diameter vs. Maximum Allowable Linear Shaft Velocity.</p> 
K series  <p style="text-align: center;">KC type KB type</p>		
TCV type TCN type 		<p>Use the average normal pressure and average linear shaft velocity within the range plotted in Graph (3). For momentary peak pressure (surge pressure) limits, use the following as a guide.</p> <p style="margin-left: 20px;">TCV type: 0.3 MPa (3kgf/cm²)</p> <p style="margin-left: 20px;">TCN type: 0.98 MPa (10 kgf/cm²)</p>
T4 series  <p style="text-align: center;">TC4 type TB4 type</p>		<p>Linear shaft velocity must be 1.5 m/s or less.</p>

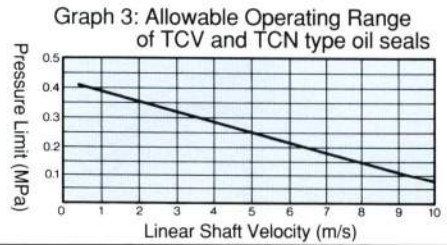

E

Note(2): The environmental temperature limits will vary depending on the type of rubber, oil, or linear shaft velocities. Generally, the limiting environmental temperature is as specified in the column "Environmental Temperature(°C)" in the table below. For details of the allowable operating temperature of various lip materials, see the section beginning on page E-12.

Note(3): For the average operating life of oil seals, refer to Fig. 5 on page J-4.

Note(4): For the definitions of shaft-to-bore misalignment and dynamic shaft run-out, refer to Fig. 2 on page E-9.

Explanation of terms under the column "Environmental Temperature"

Maximum Temperature: The temporary peak maximum temperature

Maximum Normal Temperature: The maximum temperature within the normal service temperature range, except for momentary peak temperatures.

Normal Temperature: The temperature at which the oil seal is most frequently used.

Minimum Temperature: The lowest temporary temperature

Pressure (MPa)

Environment Temperature (°C)

Maximum Allowable Total Shaft Run-out

Shaft-to-Bore Misalignment^(Note) | Shaft Dynamic Run-out^(Note)

- (1) The maximum pressure limit is 0.03 MPa (0.3 kgf/cm²).
- (2) When the lip material is nitrile rubber or fluoro-carbon rubber and the shaft diameter is less than 30 mm, a pressure higher than 0.03 MPa (kgf/cm²) is allowed. Refer to Graph (4).

Graph(4): Maximum Allowable Pressure vs. Shaft Diameter

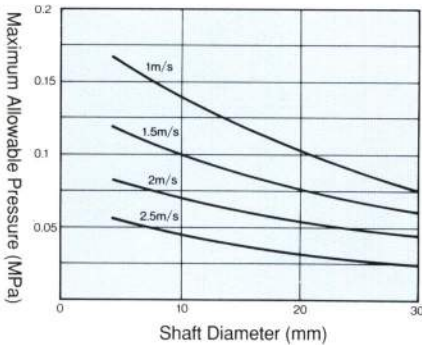

Lip Material	Maximum Normal Temperature	Normal Temperature	Minimum Temperature
A727	100	80	-30
A941	80	70	-25
T303	130	110	-15
S728	150	130	-45
F585	170	150	-15

Total Run-out is expressed as the sum of the shaft-to-bore misalignment and shaft dynamic run-out. The permissible total shaft run-out vs. shaft diameters is plotted in Graph (6). Make sure that the sum of these off-centers (i.e., the total run-out) does not exceed the permissible range in Graph (6).

$$\text{Total Shaft Run-out} = \text{dynamic shaft run-out} + [\text{shaft-to-bore misalignment} \times 2]$$

(mm TIR) (mm)

Note(1): "TIR" means total indicator reading.

Note(2): Since only the center-to-center offset is measured, the total shaft-to-bore run-out is twice as much as the center-to-center measurement.

(Example) Since the permissible total run-out is 0.35 mm TIR for a shaft diameter of 50mm running at 2000 rpm, insure that the shaft-to-bore misalignment is 0.25mm TIR or less if the shaft dynamic run-out is a maximum of 0.1mm TIR.

Graph(6): Maximum Allowable Total Shaft Run-out vs. Shaft Diameter

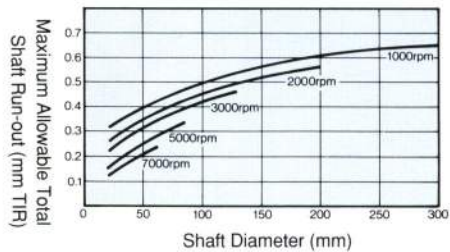

V and K type oil seals cannot be used where pressure is applied.

Lip Material	Maximum Normal Temperature	Normal Temperature	Minimum Temperature
A727	100	80	-30
A941	80	70	-25

Insure that the total shaft run-out is within the permissible range plotted in Graph (7).

Graph(7): Maximum Allowable Total Shaft Run-out vs. Shaft Diameter

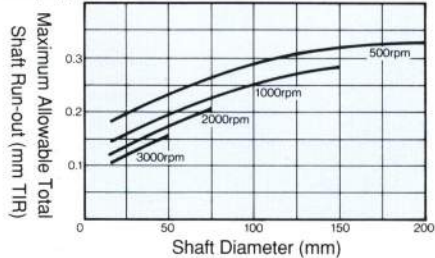

Lip Material	Maximum Normal Temperature	Normal Temperature	Minimum Temperature
A795	70	60	-11
F548	150	120	-16

0.1 mm TIR or less

0.05 mm TIR or less

Use a pressure within the permissible range plotted in Graph (5).

Graph(5): Maximum Allowable Pressure vs. Shaft Diameter

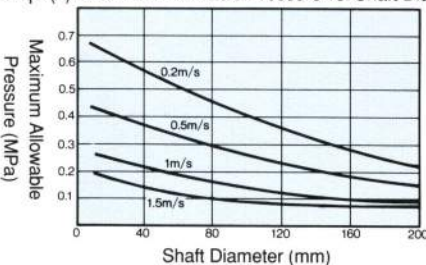

Lip Material	Maximum Normal Temperature	Normal Temperature	Minimum Temperature
A795	80	70	-11

0.2 mm TIR or less

A Guide to Allowable Operating Conditions of General Oil Seals

Table 4-1: A Guide to Allowable Operating Conditions of General Oil Seals

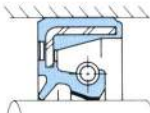
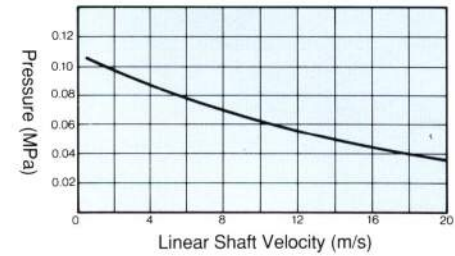
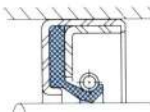
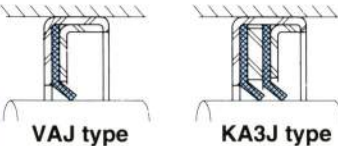
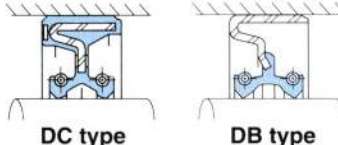
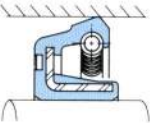
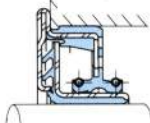
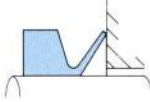
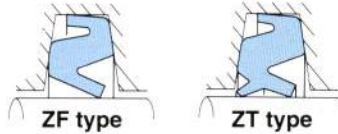
NOK Seal Type	Item	Lip Material			Allowable Operating Conditions	
		Material Family Type	NOK Material Code	Hardness (DurometerA)	Linear Shaft Velocity (m/s)	Pressure (MPa)
J type (PTFE)  TCJ type		Nitrile Rubber (NBR)	A103 + 31BF	70	Graph (8): Maximum Allowable Pressure vs. Linear Shaft Velocity 	
		Acrylic Rubber (ACM)	T302 + 31BF	70		
 SA1J type		Tetrafluoroethylene resin (PTFE)	31BF	65 Durometer D	15 or less	max0.3 {max3kgf/cm ² }
 VAJ type KA3J type					5 or less	max0.1 {max1kgf/cm ² }
D series  DC type DB type		Nitrile Rubber (NBR)	A727	70	10 or less	max0.03 or less {max0.3kgf/cm ² }
		Acrylic Rubber (ACM)	T303	80	15 or less	
OC type 		Nitrile Rubber (NBR)	A727	70	10 or less	max0.03 or less {max0.3kgf/cm ² }
QLFY type (Unitized seal) 		Nitrile Rubber (NBR)	A571	75	2 or less	max0.03 {max0.3kgf/cm ² }
VR type (End face seal) 		Nitrile Rubber (NBR)	A134	60	10 or less	Cannot be used where pressure is applied.
		Fluorocarbon Rubber (FKM)	F129	70		
Z series  ZF type ZT type		Nitrile Rubber (NBR)	A103	70	3 or less	Cannot be used where pressure is applied.

E

Figure 2: Shaft-to-Bore Misalignment and Shaft Dynamic Run-out

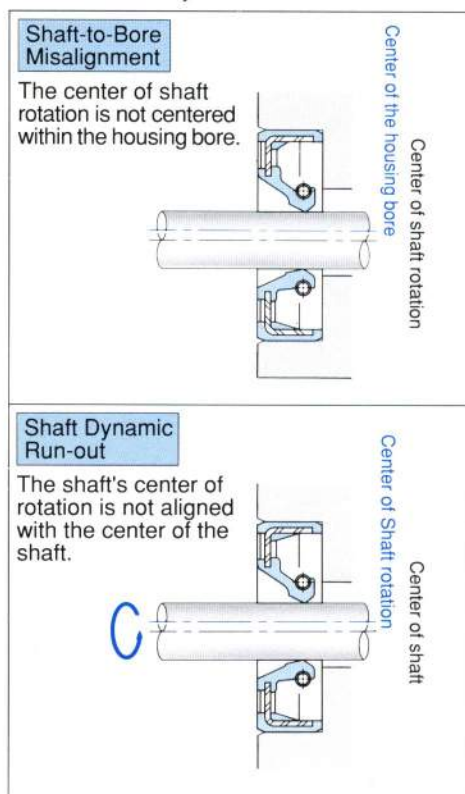

Allowable Operating Conditions			
Environmental temperature (°C)		Total Run-out (mm TIR)	
Lip Material	Minimum Temperature	Shaft diameter (d)	Total run-out
	Normal Temperature		
A103	80	$< d \leq 40$	0.2
T302	130	$40 < d \leq 80$	0.3
		$80 < d \leq 120$	0.4
Lip Material	Minimum Temperature	Shaft diameter (d)	Total run-out
	Normal Temperature		
31BF	200	$< d \leq 40$	0.15
		$40 < d \leq 80$	0.2
		$80 < d \leq 120$	0.25
		$120 < d \leq 200$	0.3
		$200 < d \leq 300$	0.35
Lip Material	Minimum Temperature	Shaft diameter (d)	Total run-out
	Normal Temperature		
A727	80	$< d \leq 40$	0.3
T303	100	$40 < d \leq 80$	0.4
		$80 < d \leq 120$	0.5
Lip Material	Minimum Temperature	Shaft diameter (d)	Total run-out
	Normal Temperature		
A727	100	$< d \leq 40$	0.25
		$40 < d \leq 80$	0.3
		$80 < d \leq 120$	0.4
		$120 < d \leq 200$	0.5
Lip Material	Minimum Temperature	0.35 or less	
A571	80		
Lip Material	Minimum Temperature	—	
	Normal Temperature		
A134	80	—	
F129	150		
Lip Material	Minimum Temperature	0.3 or less	
	Normal Temperature		
A103	80	0.3 or less	
	70		

A Guide to Allowable Operating Conditions of General Oil Seals

Table 4-2: A Guide to Allowable Operating Conditions of General Oil Seals

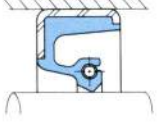
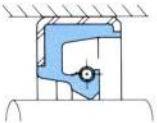
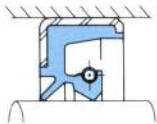
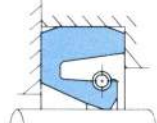
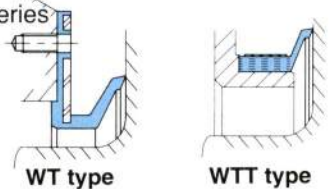
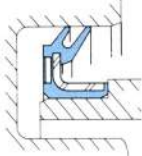
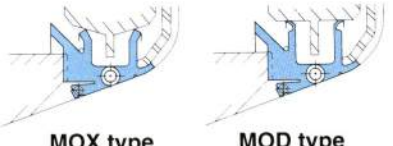
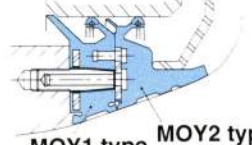
NOK Seal Type	Item	Lip Material		Allowable Operating Conditions			
		Material Family Type	NOK Material Code	Hardness (Durometer A)	Linear Shaft Velocity (m/s)	Pressure (MPa)	
SBB type 		Nitrile Rubber (NBR)	A941	80	25 or less	max0.03 {max0.3kgf/cm ² }	
Large-diameter SB type 					15 or less		
Large-diameter TB type 							
MG type 							
W series 			Lip: A103 (Exterior Surface: A992)	70 (90)	5 or less	Cannot be used where pressure is applied.	
			A104	80			
OKC3 type 			A103	70	15 or less	Cannot be used where pressure is applied.	
MO type (Morgoil) 			A989	70	25 or less		max0.03 {max0.3kgf/cm ² }
MOY type (Meseta seal) 		Hydrogenated Nitrile Rubber (HNBR) Nitrile Rubber (NBR)	Lip: G418 (Static Area: A989)	75 (70)	25 or less		

E

Figure 2: Shaft-to-Bore Misalignment and Shaft Dynamic Run-out

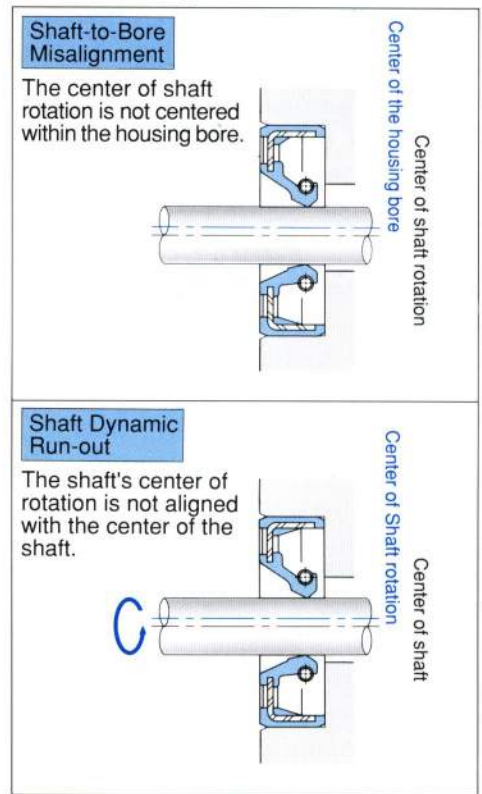

Allowable Operating Conditions														
Environmental temperature (°C)		Total Run-out (mm TIR)												
Lip Material	Minimum Temperature	<table border="1"> <thead> <tr> <th>Shaft diameter (d)</th> <th>Total run-out</th> </tr> </thead> <tbody> <tr> <td>300 < d ≤ 500</td> <td>0.4</td> </tr> <tr> <td>500 < d ≤ 700</td> <td>0.6</td> </tr> <tr> <td>700 < d ≤ 1200</td> <td>0.8</td> </tr> <tr> <td>1200 < d ≤ 2000</td> <td>1</td> </tr> </tbody> </table>			Shaft diameter (d)	Total run-out	300 < d ≤ 500	0.4	500 < d ≤ 700	0.6	700 < d ≤ 1200	0.8	1200 < d ≤ 2000	1
	Shaft diameter (d)				Total run-out									
300 < d ≤ 500	0.4													
500 < d ≤ 700	0.6													
700 < d ≤ 1200	0.8													
1200 < d ≤ 2000	1													
Normal Temperature	70													
Maximum Normal Temperature	80													
Lip Material	A941	80	70	-25										
Lip Material	Minimum Temperature	<table border="1"> <thead> <tr> <th>Shaft diameter (d)</th> <th>Total run-out</th> </tr> </thead> <tbody> <tr> <td>300 < d ≤ 500</td> <td>0.6</td> </tr> <tr> <td>500 < d ≤ 630</td> <td>1.0</td> </tr> <tr> <td>630 < d ≤ 1000</td> <td>1.6</td> </tr> <tr> <td>1000 < d ≤ 2000</td> <td>2.2</td> </tr> </tbody> </table>			Shaft diameter (d)	Total run-out	300 < d ≤ 500	0.6	500 < d ≤ 630	1.0	630 < d ≤ 1000	1.6	1000 < d ≤ 2000	2.2
	Shaft diameter (d)				Total run-out									
300 < d ≤ 500	0.6													
500 < d ≤ 630	1.0													
630 < d ≤ 1000	1.6													
1000 < d ≤ 2000	2.2													
Normal Temperature	70													
Maximum Normal Temperature	80													
Lip Material	A103	80	70	-22										
Lip Material	A104	80	70	-21										
Lip Material	Minimum Temperature	0.2 or less												
	Normal Temperature				70									
Maximum Normal Temperature	80													
Lip Material	A989	80	70	-25										
Lip Material	Minimum Temperature	2.5D/1000 D = oil seal outer diameter (mm)												
	Normal Temperature				90									
Maximum Normal Temperature	110													
Lip Material	G418	110	90	-25										



Allowable Temperature Range

Pages E-7 through E-12 describe the allowable temperature ranges for various lip materials. Note that the actual temperature limitations may vary in accordance with such factors as the type of fluid sealed or usage time. Therefore, it is necessary to consider these factors when selecting a lip material.

Temperature limitations for the S-type oil seal, which is a typical oil seal, are summarized for your reference. Please note that the temperature at the lip of the T type seal rises twice as much as the S type, and that the temperature rise of the V and K types is the same as that of the S type.

To select the proper lip material for an oil seal, it is necessary to estimate the approximate temperature at the seal lip edge of the oil seal (T_0). This temperature can be estimated by determining the maximum normal temperature of the fluid near the oil seal (T_1), and the increased underlip temperature generated by the friction between the shaft and lip (T_2). (Refer to Fig. 3.) The temperature at the sealing edge (T_0) can be given by the expression (1) below.

$$T_0 = T_1 + T_2 \quad \dots\dots(1)$$

- T_0 : Temperature at the seal lip edge
- T_1 : Temperature of sealed fluid nearest to the oil seal
(maximum normal temperature)
- T_2 : Friction-generated heat

A suitable lip material needs to be selected based on the temperature of the seal lip edge and the type of sealed fluid, and it is necessary to select a material within the upper limit of the maximum allowable temperature (T) for the lip materials shown in Table 5 on page E-15.

The permissible temperature of a lip material varies with the operating conditions of the actual equipment used.

Table 5 shows an example in which the usage time at the maximum normal temperature is within 30% of the total operating time. Thus, if the working time at the maximum normal temperature exceeds 30% of the total operating time, reduce the permissible temperature (T) by 20 °C.

For gear oil or high-viscosity silicone oil, the friction-generated heat at the lip (T_2) is 1.5 times the value shown in Fig. 3. For grease, the friction-generated heat at the lip is 3 times that shown in Fig. 3.

Figure 3: A Guide to the Friction-Generated Heat at the Seal Lip (S type)

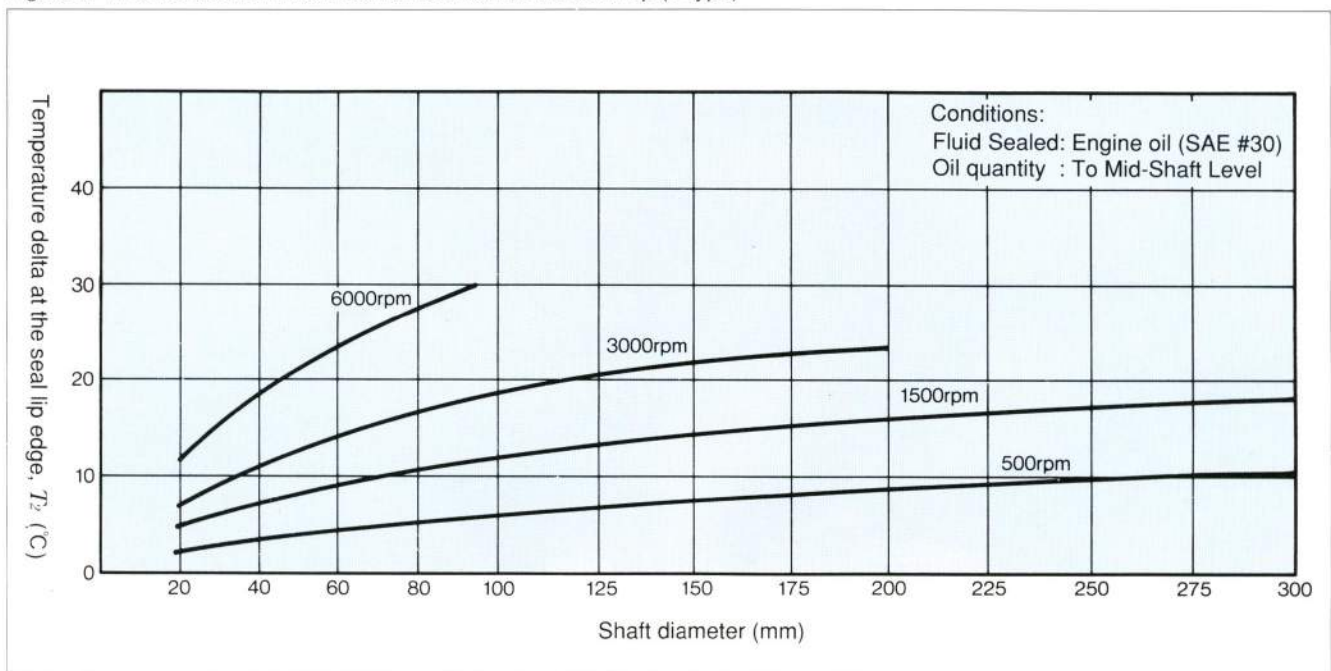

E

If the usage time at the maximum normal temperature exceeds 30% of the total working time, reduce the allowable temperature by 20°C (T-20°C)

Table 5: Allowable Operating Temperature Ranges of Various Lip Materials in S-Type Oil Seals

Types of Fluid to be Sealed		Allowable operating temperature of the lip material (maximum temperature) T(°C)																		
		40	50	60	70	80	90	100	110	120	130	140	150	160	170	180	190	200		
Engine oil	SAE#30			A727										S728						
				A941																
Gear oil	Vehicles			A727																
				A941																
Hypoid gears				A727																
				A941																
Torque converter oil Automatic transmission fluid				A727																
				A941																
Brake Fluid	DOT 3 (glycol base)																			
	DOT 5 (glycol base)																			
	DOT 5 (silicone base)																			
Turbine oil	Class 2																			
Machine oil (No.2 spindle oil)																				
Hydraulic fluid (mineral oil base)																				
Grease	Mineral oil based																			
	Silicone based																			
Fluorine based																				
Gasoline																				
Light oil, kerosene	(A795)																			
Heavy oil	(A795) A941																			

- Note (1): Only the maximum value of the allowable temperature is used.
- Note (2): The heat resistance of the fluid sealed must be greater than the lip material's resistance.
- Note (3): A727 (for a shaft diameter of 150 mm or smaller) and A941 (for a shaft diameter of 150 mm or larger) are standard materials.
- Note (4): The lip materials shown in parentheses are NOK's non-standard materials.
- Note (5): For sealing solutions not shown in the table, see pages J-7 through J32.
- Note (6): The cost guide for each material is shown on the right.
- Note (7): For water-based hydraulic fluid (water + emulsion base or water + glycol base), synthetic fluid based grease, and other oils (ester oil, glycol oil), please consult us. It is necessary to confirm that these oils are suitable for use.

Lip Material Type	Cost
Nitrile rubber	Less expensive ↑ ↓ More expensive
Acrylic rubber	
Silicone rubber	
Fluorocarbon rubber	
Tetrafluoroethylene resin (PTFE)	

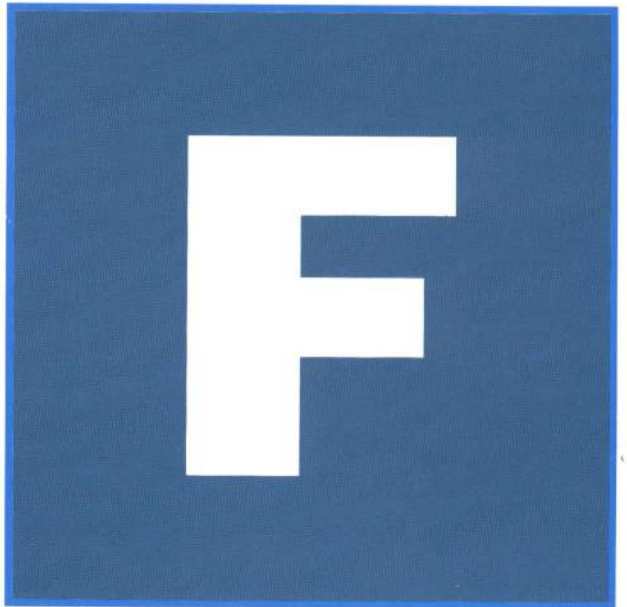

Housing and Shaft Design Guide

■ Shaft	F-2
1. Shaft Design Specifications, Chamfer Properties	F-2
2. Shaft Design Concepts	F-4
■ Housing	F-7
1. Housing Design Specifications	F-7
2. Housing Bore Configuration	F-8
3. Housing Design Concepts	F-14

F. HOUSING AND SHAFT DESIGN GUIDE

This section describes the design specifications for the shaft and the housing where oil seals are installed.

Table 1 shows reference table numbers and page numbers for the design specifications for shafts and their chamfered ends, as well as for housings and their respective chamfers, arranged by oil seal type.

Table 1: Page Directory to Shaft and Housing Design Specifications by Seal Type

NOK Seal Type		S type, T type, V type, K type, TCV type, TCN type, T4 type, J type, D type, QLFY type	SBB type, Large-diameter SB type, Large-diameter TB type	MG type	OC type, OKC3 type	VR type, Z type
Shaft	Design specifications	Table 2 on page F-2			Table 11 on page F-12	Table 12 on page F-13
	Chamfer specifications	Table 3 on page F-3	Table 4 on page F-3	Table 3 on page F-3		Table 3 on page F-3
Housing	Design specifications	Table 6 on page F-8			Table 10 on page F-11	Table 11 on page F-12
	Chamfer specifications	Table 7, 8 on page F-8, 9	Table 9 on page F-10			

Note : Please consult us regarding the design of the shaft and housing for W type, MO type, and MOY type oil seals.

Shaft

1. Shaft Design Specifications, Chamfer Properties

Table 2 shows shaft design specifications, and Tables 3 and 4 show the shape and size of the required shaft chamfers.

Table 2: Shaft Design Specifications

NOK Seal Type	S type, T type, V type, K type, TCV type, TCN type, D type, SBB type, Large-diameter SB type, Large-diameter TB type, MG type	J type	T4 type	QLFY type
Specification item				
Shaft Material	Carbon steels for machine structural use			
Surface hardness	Min. 30 HRC	Min. 50 HRC	Min. 30 HRC	
Surface roughness	(0.32~0.1) $\mu\text{m Ra}$ (2.5~0.8) $\mu\text{m Rz}$		(0.2~0.05) $\mu\text{m Ra}$ (1.6~0.4) $\mu\text{m Rz}$	(3.2~1.6) $\mu\text{m Ra}$ (12.5~6.3) $\mu\text{m Rz}$
Machining method	Plunge ground		After heat treatment, plate with hard chrome before final polishing.	Lathe cut
Dimensional tolerances	JIS h9			JIS h8

Note (1): To use oil seals with a silicone rubber lip, finish the shaft surface roughness at 1.6 to 0.6 $\mu\text{m Rz}$.

Note (2): For details on shaft machining, refer to "Proper Shaft Machining Methods" on page F-5.

Table 3: Shaft Chamfer Design (for shafts up to 300 mm in diameter)

Units: mm

NOK Seal Type Shaft diameter	S type, T type, V type, K type, TCV type, TCN type, T4 type, D type, MG type, VR type, Z type	J type	QLFY type
Shaft diameter d	d ₁		
Up to 10	d - 1.5	d - 3.5	—
Over 10 to 20	d - 2.0	d - 4.0	
Over 20 to 30	d - 2.5	d - 4.5	
Over 30 to 40	d - 3.0	d - 5.0	
Over 40 to 50	d - 3.5	d - 5.5	
Over 50 to 70	d - 4.0	d - 6.0	d - 1.5
Over 70 to 95	d - 4.5	d - 6.5	
Over 95 to 130	d - 5.5	d - 7.5	
Over 130 to 240	d - 7.0	d - 9.0	d - 2.0
Over 240 to 300	d - 11.0	d - 12.0	

The diameter d₁ in the table is less than the inside diameter of the sealing lip. Remember that a correct installation neither damages the sealing lip nor detaches the garter spring. Be sure to conform to the relevant size shown in the table.

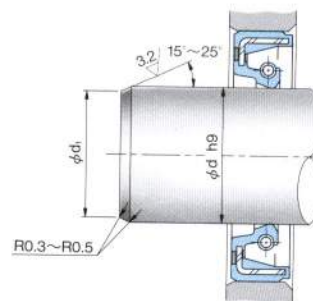

Table 4: Shaft Chamfer Design for SBB type, large-diameter SB type and large-diameter TB type Oil Seals (for shafts over 300 mm in diameter) Units: mm

NOK Seal Type Shaft diameter	SBB type, Large-diameter SB type, Large-diameter TB type	
Shaft diameter d	d ₁	
Over 300 to 400	d - 12	
Over 400 to 500		
Over 500 to 630	d - 14	
Over 630 to 800		
Over 800 to 1000		
Over 1000 to 1250	d - 18	
Over 1250 to 1600		
Over 1600 to 2000	d - 20	

2. Shaft Design Concepts

The material, hardness, and machining method of the shaft has a significant influence on the performance of the oil seal. Design specifications for the shaft need to be determined after careful examination of all relevant factors.

(1) Shaft Material

Steels for machine structural use, are suitable. However in case of cast iron or plastic, refer to **Table 5** “Notes on Usage” before selecting one of these materials.

Table 5: Notes on Usage

Shaft Material	Notes on Usage
Cast Iron	Pinhole porosity is likely to appear in cast iron shafts. If the size of the pinhole is larger than 0.05 mm, and the seal lip rides in or around this pinhole, leaks may occur. This is due to a localized and rapid loss of shaft contact to the seal lip. If cast iron shafts must be used, NOK recommends using nodular graphite cast iron shafts.
Plastics	NOK does not recommend using plastic shafts. It is difficult to insure proper hardness and surface finish, and heat dissipation is poor due to low heat transfer qualities.
Ceramics	Although ceramic shafts may be used in chemical equipment, ceramic shafts are not recommended for use with oil seals. The unique surface roughness of ceramics accelerates seal lip wear, significantly reducing the life of the oil seal. Consult us before using ceramic shafts.

(2) Shaft Hardness

The surface of the shaft with which the sealing lip of an oil seal comes into contact needs to be at least 30 HRC for the following reasons:

1. The shaft surface will not be easily scratched or dented.
2. An appropriate surface finish can be easily machined.
3. The shaft (especially a hollow shaft) will not deform easily.

Dents are easily overlooked, however, and it is important to take care that the shaft is not damaged by contact during shipping and assembly.

For use with J type (PTFE) seals, the shaft surface under the seal lip needs to be as hard as 50 to 60 HRC, as the J type oil seal is more likely to increase wear on the shaft compared to other oil seals. The J type oil seal is used for fluids with poor lubricity, such as chemicals or solvents, and in high temperature areas or under poor lubrication conditions. Therefore, a shaft with a hardness of only 30 to 40 HRC will quickly wear out.

(3) Shaft Finish and Machining Method

Generally, the shaft roughness directly affects the degree of seal leakage and wear (this varies according to shaft speed and oil quantity) regardless of the shaft hardness. Therefore, it is important to use shafts with the surface finish roughnesses listed in **Table 2**. For rotating shaft oil seals, special attention is needed. If machining flaws run continuously along the shaft, leaks may occur even if the surface roughness of the shaft is within a range of 2.5 to 0.8mm Rz (excluding T4 type and QLFY type oil seals).

The following section discusses proper and improper machining methods (i.e., introducing machine lead onto the shaft through poor machining practices).

Proper Shaft Machining Methods

Ground Finish

Plunge grinding produces non-continuous machining striation markings that are at right angles to the shaft centerline, as shown in the photograph on the right. This is the optimum finish technique for best seal life and performance. After plating with hard chromium to improve resistance to corrosion and wear, be sure to plunge-grind the final surface.

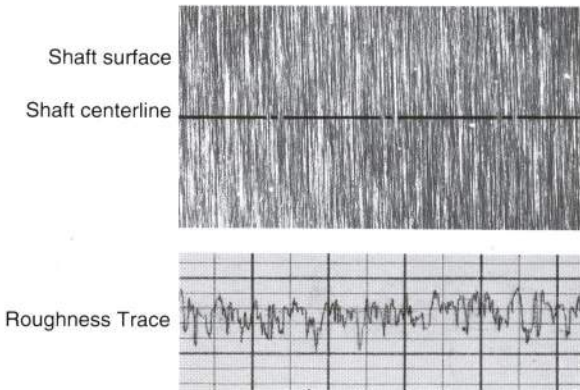

Emery Paper Finish

(a finishing method that does not involve moving the paper axially) Emery paper finishing without axial movement produces non-continuous machining striation markings that are at right angles to the shaft centerline, as shown in the photograph on the right.

This “plunge” action surface is therefore also very suitable for oil seals.

Note that excessive force on the paper may produce deep scoring on the shaft.

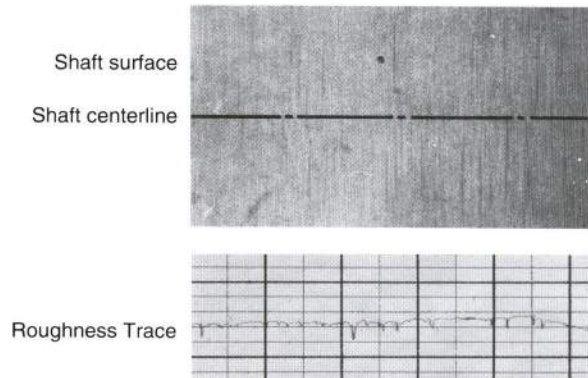

How to Minimize Shaft Wear

A shaft may experience wear even if it is treated via induction or carburizing hardening processes. This is primarily due to dust, earth and sand, or silica (SiO_2) or alumina (Al_2O_3) contained in deteriorated oil. These minute foreign particles can enter into the contact area of the sealing lip either from the air or oil side. To protect the shaft from wear caused by particles from the air side, NOK recommends using a dust seal together with an oil seal, or selecting an oil seal with higher dust resistance.

When the oil contains high levels of silica or alumina, shaft wear can be reduced by changing the oil at appropriate intervals. In addition, hard chromium plating of the shaft or using hard chromium plated sleeve shafts is recommended.

Grindstone Dressing

Take care when dressing the grindstone for plunge ground finishing. If the grindstone incurs directional lead during the dressing, the lead will transfer to the shaft. NOK recommends roller dressing. If single-point dressing is unavoidable, use a slow feed rate and be sure to spark-out during grinding.

Improper Shaft Machining Methods

Lathe Cut Finish

Lathe finishing is very distinctive: a roughness curve shows continuous rows of well-shaped triangular peaks and valleys spiralling around the shaft. These spiral valleys can continue from the inner side of the oil seal, through the sealing lip contact area, and to the air side, causing sealed fluid to leak through the valleys via a “screw-pump” action.

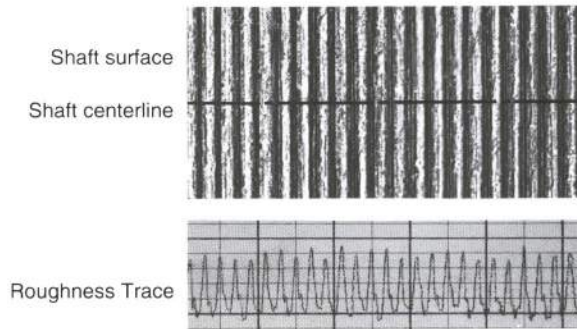

Super-finishing

Super-finishing creates a herringbone-like texture, and reduces roughness compared to other finishing methods. However, this texture also causes seal leakage through the presence of machine lead, which can overpower a seal and pump oil to the air side. In some cases, this herringbone-like texture can cause premature wear on the seal lip.

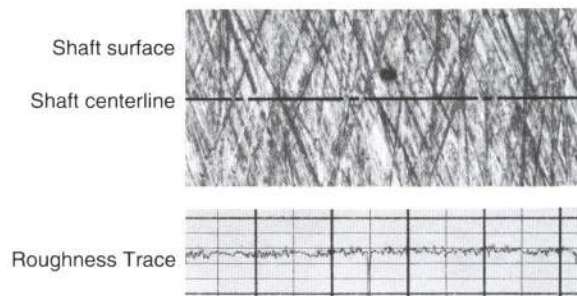

Roller Burnishing

Roller burnishing is generally performed after a lathe cutting operation. The burnishing will not remove the substrate machine lead produced by the lathe, which could cause leakage. Roller burnishing is also prone to producing a too-smooth finish, causing the oil film to become too thin, resulting in increased friction and premature seal wear.

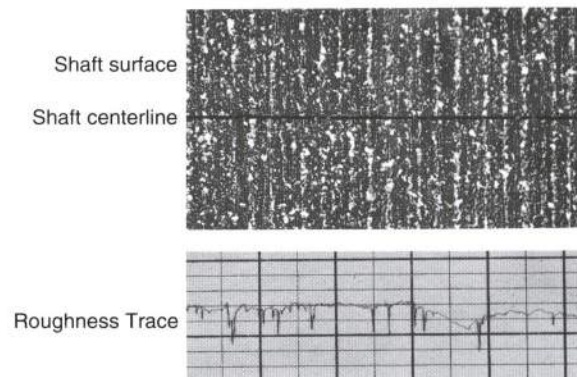

Emery Paper Finishing

(With axial oscillation)

After lathe machining, finishing the surface with emery paper is the easiest and most widely accepted method. However, finishing by moving the emery paper axially produces a herringbone lead texture, causing leaks to occur (similar to super finishing).

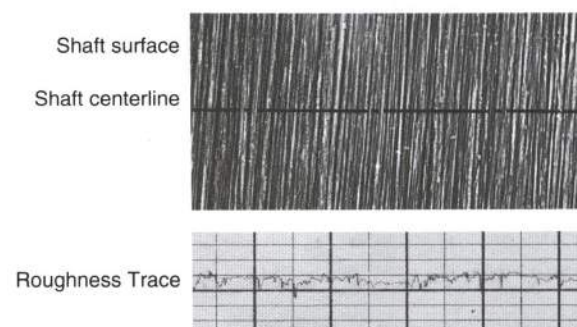

(4) Shaft Chamfer

If there is a sharp corner at the shaft's end, the seal lip will be damaged when the oil seal is installed over the shaft, thus causing a leak. Also, if the shaft is not properly chamfered, the sealing lip might get caught on the corner as shown in Fig. 4, causing lip "turn-under" and possible garter spring ejection. Therefore, the shaft should be properly chamfered as shown in Tables 3 and 4.

Figure 4: Lip "Turn-Under" and Garter Spring Ejection

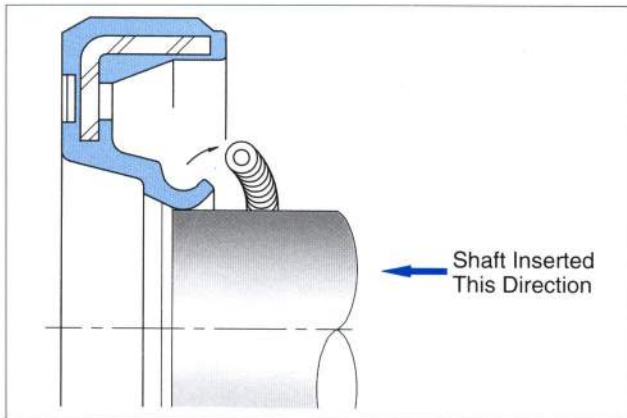

(5) Shaft Key Ways and Splines

Even if the shaft is properly chamfered per Tables 3 and 4, the seal lip may be damaged if there is a key way or spline on the shaft surface which the lip contacts during installation.

If a key way or spline must be used on the shaft surface that will pass under the seal's lip during installation, make the nominal diameter of the key way or spline 5 to 15mm smaller than the diameter of the shaft's seal journal so that a cover may be used, as shown in Figure 5.

(6) Miscellaneous

If a shaft's bearing journal is the same diameter as the shaft's seal journal, the shaft will be scratched from bearing installation, and thus cause a leak path under the seal lip. Instead, design the shaft's bearing journal to be larger than that of the seal journal, thus avoiding shaft damage in the critical seal lip area of the shaft.

Housing

The housing is the area where a bore recess can receive and retain a seal.

Table 6 shows the most desirable design characteristics for housing bores, and Tables 7 and 8 show the shapes and sizes of various housing bores.

1. Housing Design Specifications

Design specifications for housings are shown in Table 6. Refer to Table 10 for MG type, Table 11 for O type, and Table 12 for VR and Z type oil seals.

2. Housing Bore Configuration

The shape and size of a housing bore needs to be determined according to the type and size of the oil seal to be used. Design a housing bore based on the following:

(1) Standard Oil seals

For standard oil seals (with shafts up to 300 mm in diameter), the shape and size of the housing hole varies depending on the pressure in the application.

Non-Pressurized Applications

(Max. 0.03 MPa (0.3 kgf/cm²))

The shapes and sizes of housing bores in non-pressurized applications are shown in Table 7.

Figure 5: Cover Design for Key Ways or Splines

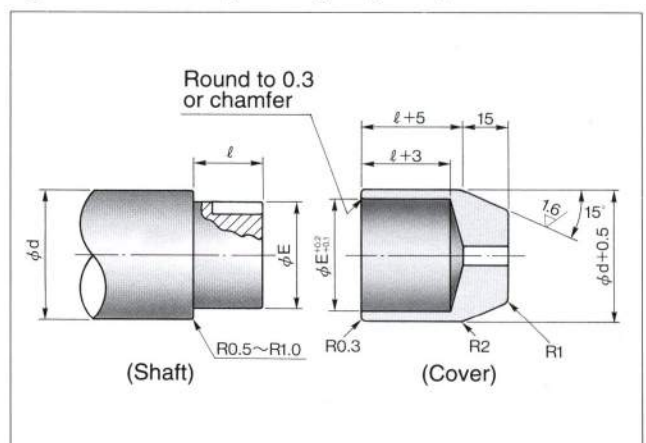

Table 6: Housing Design Specifications

NOK Seal Type		Specification item	S type, T type, V type, K type, TCV type, TCN type, T4 type, J type, SBB type, Large-diameter SB type, Large-diameter TB type, D type, QLFY type
Housing Material			
Bore ID surface roughness	Metal OD oil seal	(3.2 ~ 0.4) μm Ra (12.5 ~ 1.6) μm Rz	
	Rubber OD oil seal	(3.2 ~ 1.6) μm Ra (12.5 ~ 6.3) μm Rz	
Dimensional tolerance	Nominal size: 400 mm or smaller	JIS H8	
	Nominal size: 400 mm or larger	JIS H7	

Table 7: Housing Bores for Non-Pressurized Applications

Housing bore size Units: mm

Nominal width of oil seal (b)	Minimum size of W_1	B	Minimum size of W_2
Up to 6	b + 0.5	1.0	b + 1.0
Over 6 to 10		1.5	
Over 10 to 14		2.0	
Over 14 to 18		2.5	
Over 18 to 30	b + 1.0	3.0	b + 2.0

Units: mm

Nominal outside diameter of oil seal (D)	K
Up to 50	D-4
Over 50 to 150	D-6
Over 150 to 300	D-8

F

Pressurized Applications

(0.03 MPa (0.3 kgf/cm²) or higher)

The housing bore designs to be used in the presence of internal pressure are shown in **Table 8**.

Table 8: Housing Bore Design for Pressurized Applications

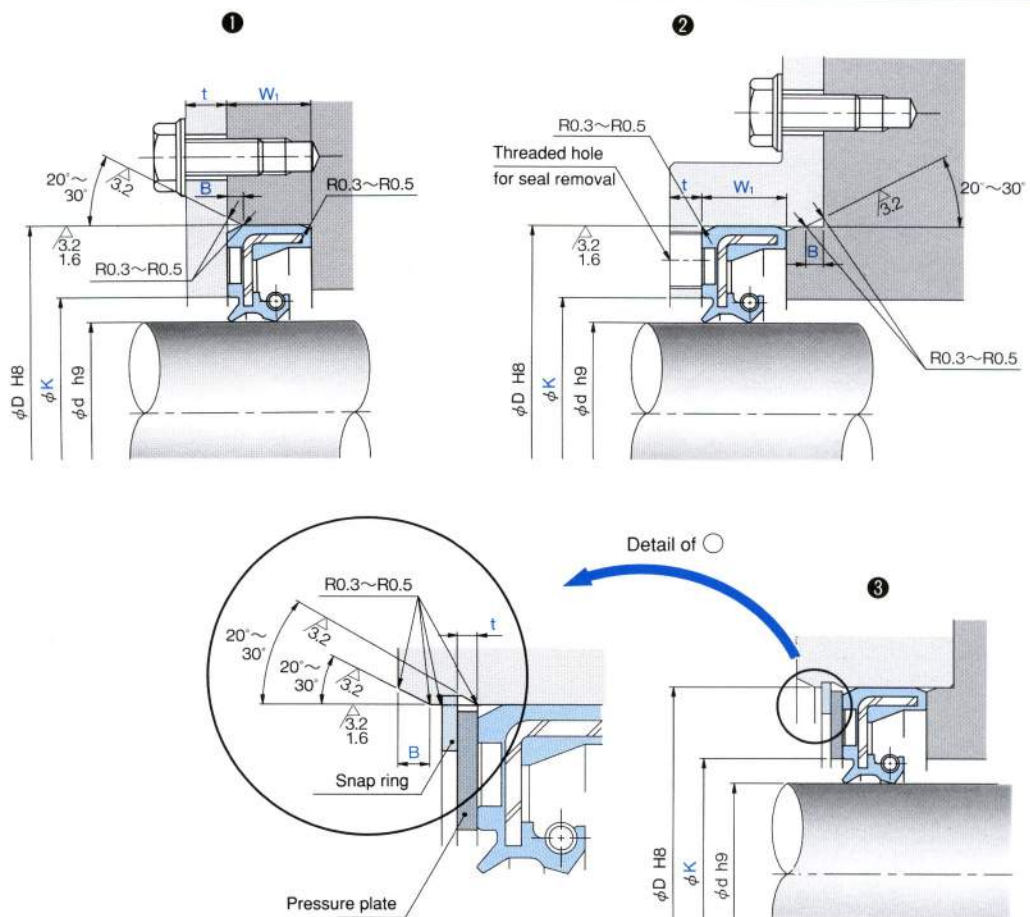

Housing bore size Units: mm

Nominal width of oil seal (b)	W_1	B
Over 6 to 10	$b +0.3$ $+0.5$	1.5
Over 10 to 14	$b +0.4$ $+0.6$	2.0
Over 14 to 18	$b +0.5$ $+0.8$	2.5
Over 18 to 30	$b +0.6$ $+0.9$	3.0

Pressure plate size Units: mm

Nominal outside diameter of oil seal (D)	K	Minimum plate thickness t
Up to 50	d+3	3
Over 50 to 120	d+4	5
Over 120 to 250	d+5	8
Over 250	d+6	10

(2) General Oil Seals

For general oil seals, design the housing bore based on the following.

The shape and size of housing holes for SBB type, large-diameter SB type, and large-diameter TB type oil seals are shown in Table 9.

Table 9: Bore Design for **SBB type, large-diameter SB type, and large-diameter TB type** (shaft over 300 in diameter) oil seals

Housing design specifications		Units: mm	
Nominal outside diameter of oil seal (D)	K		
Over 300 to 400	D-10		
Over 400 to 500			
Over 500 to 630	D-12		
Over 630 to 800			
Over 800 to 1000			
Over 1000 to 1250			
Over 1250 to 1600	D-14		
Over 1600 to 2000			

Housing bore size		Units: mm	
Nominal width of oil seal (b)	W_i	B	
Up to 6	b+0.5	1.0	
Over 6 to 10		1.5	
Over 10 to 14		2.0	
Over 14 to 18		2.5	
Over 18 to 30	b+1.0	3.0	

MG Type Oil Seal

Design specifications of the housing bores for MG type oil seals are shown in **Table 10**. Since no reinforcing metal case is used in an MG type oil seal, the seal is installed by cutting the seal at one point and butt-jointing the cut ends, which makes it difficult to obtain the proper retention strength.

Therefore, the housing bore must be designed so that the oil seal sits at the correct position and is secured by pressure from both sides.

Table 10: Housing Bore Design Specifications for MG Type Oil Seals

Housing design specifications		Housing bore size			Units: mm	
Item	Specifications	Nominal width of oil seal (b)	W	B		
Housing Material	Metals with low thermal expansion coefficients (Example: Carbon steels for machine structural use)	Up to 6	b ^{-0.1} _{-0.2}	1.0		
Bore Inner Diameter Surface Roughness	(3.2 ~ 1.6) μm Ra (12.5 ~ 6.3) μm Rz	Over 6 to 10	b ^{-0.1} _{-0.3}	2.0		
Method	Machining	Over 10 to 14	b ^{-0.1} _{-0.4}	3.0		
Dimensional tolerances	400mm or smaller nominal outside diameter	Over 14 to 18	b ^{-0.1} _{-0.5}	4.0		
	400mm or larger nominal outside diameter	Over 18 to 30	b ^{-0.1} _{-0.6}	5.0		
		Over 30	b ^{-0.1} _{-0.7}	6.0		

Nominal outside diameter of oil seal (D)	C	Pressure plate		Mounting bolt		Units: mm
		Minimum plate thickness t	K	Size	Quantity	
Up to 50	d + 8	3	d + 3	M6	4 (equally spaced)	
Over 50 to 125	d + 10	5	d + 5	M8	4 (equally spaced)	
Over 125 to 315	d + 18	10	d + 8	M10	6 (equally spaced)	
Over 315 to 400	d + 25	15	d + 12	M12	8 (equally spaced)	
Over 400 to 500						
Over 500 to 630						
Over 630 to 800	d + 28	18			12 (equally spaced)	
Over 800 to 1000						
Over 1000 to 1250	d + 30	20	d + 15	M16	16 (equally spaced)	
Over 1250 to 1600						
Over 1600 to 2000						

OC and OKC3 Type Oil Seals

The sealing lip of an OC type oil seal comes into contact with the inner surface diameter of the housing bore, while the sealing lip of an OKC3 type oil seal comes into contact with the inner diameter surface of the shaft flange. The machining methods for these inner diameter surfaces and the surface roughnesses are shown in Table 11.

Table 11: Housing and Shaft Design Specifications for OC and OKC3 Type Oil Seals

Units: mm

Item	Classification Seal Type	Shaft design specifications		Housing(inner diameter surface) design specifications	
		OC type	OKC3 type	OC type	OKC3 type
Housing Material		Carbon steels for machine structural use			
Surface hardness		Min. 30 HRC			
Surface roughness		(3.2 ~ 1.6) μm Ra (12.5 ~ 6.3) μm Rz		(0.4 ~ 0.2) μm Ra (3.2 ~ 1.6) μm Rz	(0.8 ~ 0.4) μm Ra (6.3 ~ 3.2) μm Rz
Method		Machining		Plunge ground Machining	Machining
Dimensional tolerances	Nominal size: 400 mm or smaller	JIS h8		JIS H9	
	Nominal size: 400 mm or larger	JIS h7			

Shape and size of housing bore (inner diameter surface)

OKC3 type

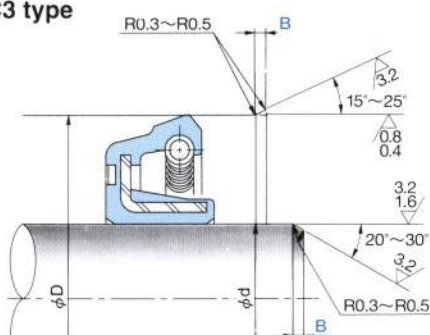

OC type

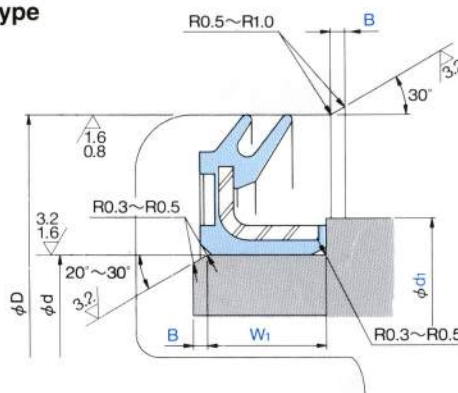

Nominal width of oil seal (b)	W_1	B	d_1
Up to 6	b+0.5	1.0	d+10
Over 6 to 10		1.5	
Over 10 to 14		2.0	
Over 14 to 18		2.5	
Over 18 to 30	b+1.0	3.0	

VR and Z Type Oil Seals

Design specifications for the shafts and housings of VR and Z type oil seals are shown in Table 12.

Table 12: Shaft and Housing Designs for VR and Z Type Oil Seals

Units: mm

Item	Classification Seal Type	Shaft design specifications		Housing design specifications	
		VR type	Z type	VR type*	Z type
Housing Material		Carbon steels for machine structural use			
Surface hardness		Min. 30 HRC		No requirement	
Surface roughness		(3.2 ~ 1.6) $\mu\text{m Ra}$ (12.5 ~ 6.3) $\mu\text{m Rz}$	(0.4 ~ 0.2) $\mu\text{m Ra}$ (3.2 ~ 1.6) $\mu\text{m Rz}$	(1.6 ~ 0.2) $\mu\text{m Ra}$ (6.3 ~ 0.8) $\mu\text{m Rz}$	(0.8 ~ 0.2) $\mu\text{m Ra}$ (6.3 ~ 1.6) $\mu\text{m Rz}$
Method		Machining			

* The housing roughness specification for the VR type seal is only required where the seal lip contacts the housing axially.

Mating Face Design

VR type

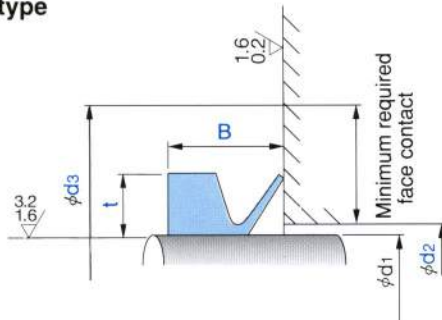

Shaft diameter d_1	B	d_2	d_3	t
Up to 3	2.5 ± 0.3	$d+1$	$d+4$	1.5
Over 3 to 10	3.0 ± 0.4		$d+6$	2.0
Over 10 to 20	4.5 ± 0.6	$d+2$	$d+9$	3.0
Over 20 to 40	6.0 ± 0.8	$d+3$	$d+12$	4.0
Over 40 to 70	7.0 ± 1		$d+15$	5.0
Over 70 to 110	9.0 ± 1.2	$d+4$	$d+18$	6.0
Over 110 to 160	10.5 ± 1.5		$d+21$	7.0
Over 160 to 200	12.0 ± 1.8	$d+5$	$d+24$	8.0
Over 200	20.0 ± 3.0	$d+10$	$d+45$	15.0

Housing Bore (inner surface diameter)

Z type

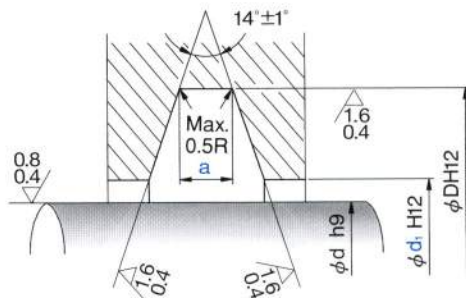

Shaft diameter d	d_1
Up to 20	$d+1.0$
Over 20 to 60	$d+1.5$
Over 60 to 110	$d+2.0$
Over 110	$d+3.0$

Groove width a	Dimensional tolerance
Up to 3	+0.14 0
Over 3 to 6	+0.18 0
Over 6 to 10	+0.22 0
Over 10 to 18	+0.27 0

3. Housing Design Concepts

The material, roughness, size, and shape of the housing bore will affect the performance of the oil seal. Determine the design specifications after careful consideration of these factors.

(1) Housing Material

For steel or cast iron housings, use either rubber OD or metal OD seals. Since light alloys or resins generally have high coefficients of thermal expansion, the size of the housing hole increases as the temperature increases. For metal OD oil seals, leakage may occur in the press-fit area, or the seal itself may become dislodged. If light alloy or plastic housings must be used, use rubber OD seals.

(2) Surface Roughness of Housing Bore (inner diameter surface)

Oil seals prevent leakage by maintaining contact between the sealing edge and shaft and also by obtaining a proper fit to the bore. Thus, care is needed when machining the housing hole. A very rough inner housing surface will create a leak path past the seal. Refer to **Table 6** on page F-8 for proper roughness levels.

(3) Dimensional Tolerances of Housing Bores

At NOK, we define outside diameter tolerances for oil seals based on JIS H8 for oil seals with 400 mm or smaller nominal outside diameters and JIS H 7 for oil seals with 400 mm or larger nominal outside diameters.

If JIS H8 or JIS H7 standards are not used, seal installation may be difficult, cause damage, or even fail to be retained during operation.

(4) Housing Bore Design

If excessive weight or pressure is placed on the oil seal, it may become dislodged. No special care is needed if there is no inner pressure on the oil seal (max. 0.03 MPa (0.3 kgf/cm²)). In applications where the pressure is 0.03 MPa (0.3 kgf/cm²) or larger, design the housing so that it secures the oil seal axially. The shape and size of the housing bores are shown in **Table 8** on page F-9. You can select either configuration ① or ② in the table. Configuration ② allows easy installation and removal of the oil seal. If a snap ring must be used, round (blend) the snap ring groove edges of the bore as shown in ③.

(5) Split-Type Housing

Avoid using a split-type housing for the following reasons:

- ① Leakage may occur from the split line area.
- ② Seal displacement may occur at the split line area.
- ③ It may be difficult to ensure proper roundness of the housing bore.
- ④ Misalignment may occur between the shaft and housing hole.

Items ② and ③ result in leaks at the split line area, and item ④ results in leaks at the sealing lip.

If a split-type housing must be used, machine the housing so that it does not misalign and become oval-shaped, and then use a rubber OD seal in the pre-assembled housing.

Figure 2: Split-Type Housing

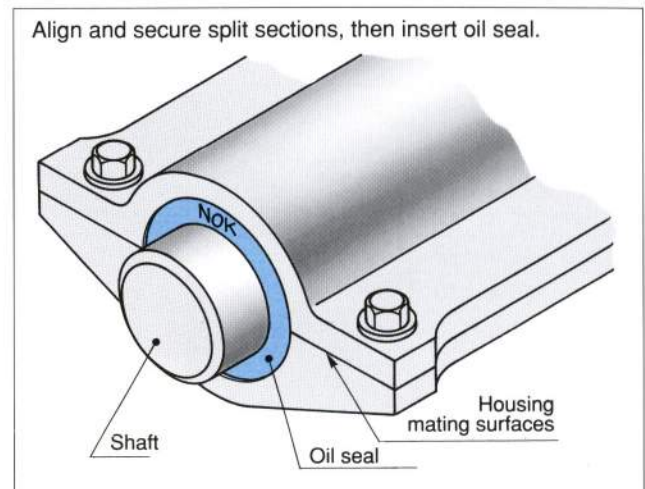

(6) Improper Housing Bore Designs

Figure 3 illustrates two improper housing designs. For case **①**, since stamped steel is used, the hole surface is apt to be tapered and the inside diameter or roundness will vary, causing the oil seal to leak or even become dislodged.

For the housing design in **②**, the housing may be installed off-center, as it uses a combination of screws. Do not use a screwed-in housing.

Figure 3: Improper Housing Bore Designs

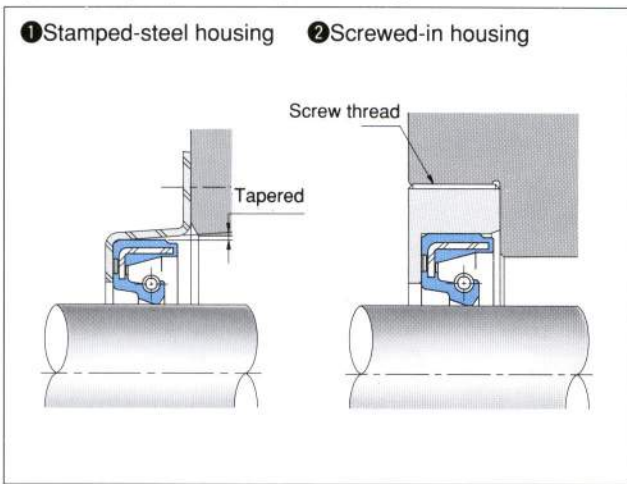



Seal Handling Guide

- Seal Handling Guide ————— G-2
- 1. Handling NOK's Standard Oil Seals ————— G-2
- 2. Handling NOK's General Oil Seals ————— G-9

Even if you correctly designed or selected the shaft and housing into which the oil seal is installed, rough handling or assembly of the oil seal may result in the oil seal being unable to function as intended. This chapter discusses proper handling of oil seals during assembly and replacement. Before using an oil seal, read and follow the relevant instructions.

■ Handling NOK's Standard Oil Seals

Use the following as guide to proper seal handling.

1. Packaging

Oil seals are packaged in bags, rust-preventing paper, or corrugated cardboard boxes, depending on the size or quantity. The packaging is necessary to protect the oil seal against rust, damage, and foreign matter. Only open the package immediately before use.

2. Storage

(1) Storage Precautions

Follow these instructions when storing oil seals.

- ❶ Do not open the package until needed, as the oil seals may become contaminated or damaged.
- ❷ Do not expose the oil seal to direct sunlight for extended periods of time. Ultraviolet rays may hasten the deterioration of rubber.
- ❸ Do not place the oil seal in locations where it may be exposed to excessive moisture. Rust can form on the external metal or garter spring of the oil seal.
- ❹ Do not place the oil seal near heat sources, such as a boiler or stove. Heat accelerates the deterioration of rubber.
- ❺ Avoid hanging the oil seal on nails or steel wires, or dangling the oil seal using a cord. The oil seal may be deformed, or its sealing edge may be damaged.
- ❻ When storing the oil seal after opening its package, take care to protect it from rust, as well as foreign particles such as dust and sand.
- ❼ Avoid excessive shock during handling or transit to prevent deformation of the oil seal or dislodging the garter spring.

(2) Storage Time

The table below shows the maximum shelf life of properly stored oil seals.

Product	Material	Shelf Life
100% Rubber Products	Nitrile rubber (NBR)	10 years
	Acrylic rubber (ACM)	20 years
	Silicone rubber (VMQ)	20 years
	Fluorocarbon rubber (FKM)	20 years
Rubber/Metal Bonded Products	Nitrile rubber (NBR)	10 years
	Acrylic rubber (ACM)	10 years
	Silicone rubber (VMQ)	10 years
	Fluorocarbon rubber (FKM)	10 years

3. Protect the Shaft and Housing

Take care not to damage the shaft and housing before assembly, as leaks may occur. Use a carrying jig to prevent the finished surfaces of the shaft and housing from contacting other objects, as indicated below.

Figure 1 shows a storage jig for housings. Each housing is placed so that it leans against individual partitions to prevent damage. This jig is made from plastic to prevent the metal part from being scratched.

Figure 12 shows a storage/transport cap jig for shafts. Placing this plastic cap over the shaft prevents the shaft from being damaged.

Figure 1: Housing Storage Jig

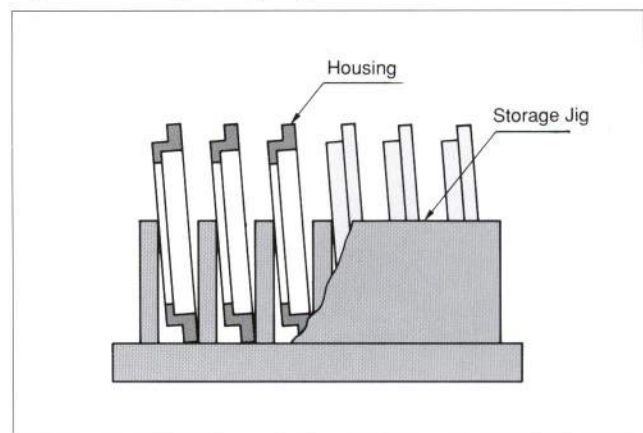
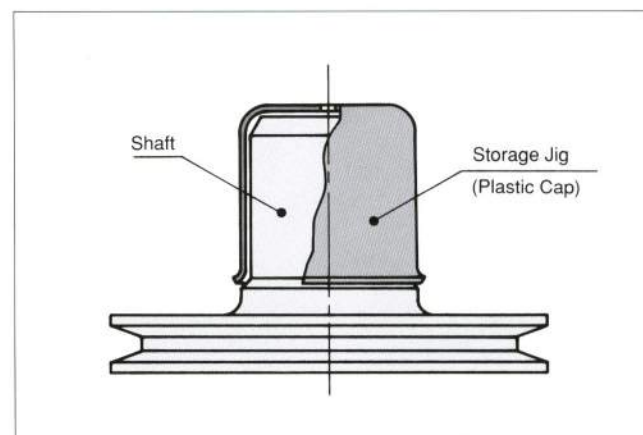

Figure 2: Shaft Storage Jig



- The storage periods shown on the left are applicable to products sealed in standard packaging and stored in a cool dry place away from direct sunlight.
- The indicated storage periods do not account for rust formation on the metal parts of bonded seal products, since rust is largely influenced by the storage environment.
- Before using an oil seal that has been kept in storage for an extended period of time, check that it is free from rust.
- A white powder may appear on the surface of rubber products (known as "bloom phenomenon"). This does not affect oil seal performance.

4. Preparation Before Assembly

(1) Oil seal

- 1 Do not use an oil seal that has dust or sand on it, as leakage may occur.
- 2 Do not scrape the sealing edge of the oil seal with nails or other hard objects. The sealing edge is the most important part in determining oil seal performance.
- 3 For an oil seal having two or more lips, such as the T type and K type oil seals, apply mineral based lithium grease (for example, Sealube S1 made by NOK) between the lips to lubricate the lips. (See Fig. 3.).
- 4 For an oil seal having only one lip, such as the S type, V type, and TCK type oil seals, coat the seal lip edge with grease to lubricate the lip.

For recommended greases, refer to page K-11.

Figure 3: How to Apply Grease

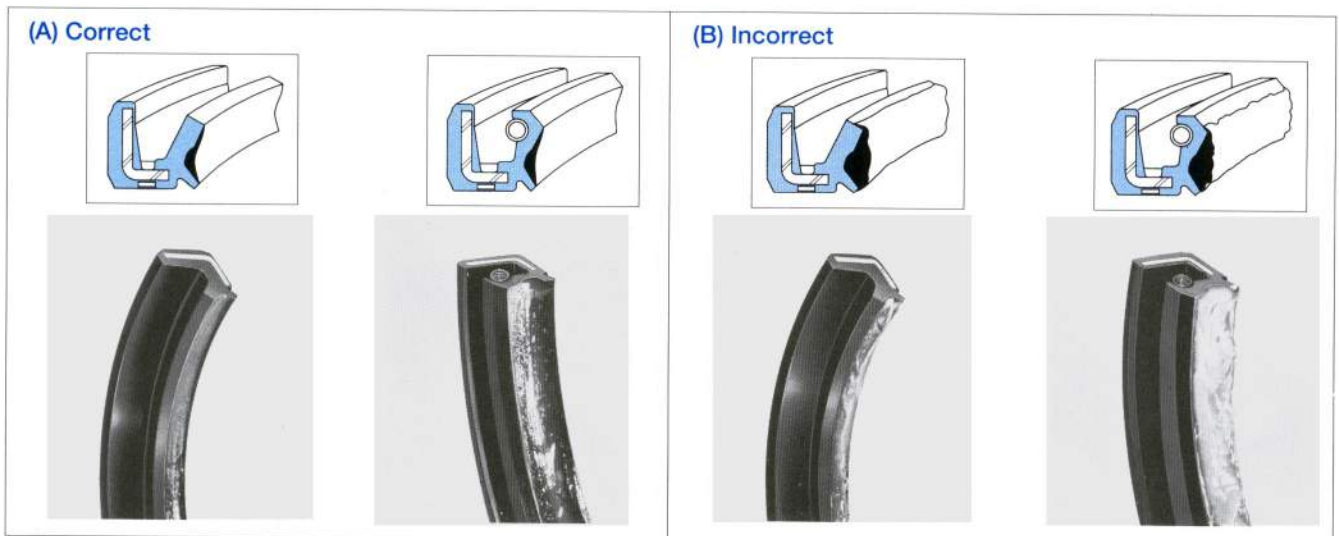

Apply the grease so that it does not overflow past the lip, as shown in (A).

Applying too much grease, as shown in (B), may cause overflow during assembly that may be mistaken for leakage.

(2) Shaft and Housing

- 1 Check that the shaft surface and the housing bore are free of rust preventatives, dust and grit. If these impurities exist, clean thoroughly to remove. If oil or gasoline is used for cleaning, carefully wipe the area dry.

Also, spraying compressed air is effective, as it cleans areas that are not readily visible. Residual oil or gasoline on the shaft or the housing bore can result in the oil seal swelling to an incorrect size, which may cause leaks.

- 2 Check that the inner surface of the housing bore and the chamfered area, as well as the shaft end and the shaft surface into which oil seal is inserted are free of defects and burrs. Remove any irregularities with emery paper to prevent damage to the sealing edge or outer surface during assembly.
- 3 Check that the shaft surface that the sealing edge will contact is free of defects and rust, thus preventing leaks from those causes.

5. Installing the Seal Into the Housing Bore

(1) Installing the Seal

- ❶ Orient the seal so that the seal lip faces the fluid to be sealed, as shown in Figure 4.
- ❷ Install the seal squarely using the jig as illustrated in Figure 5.

Figure 4: Orientation of the Seal

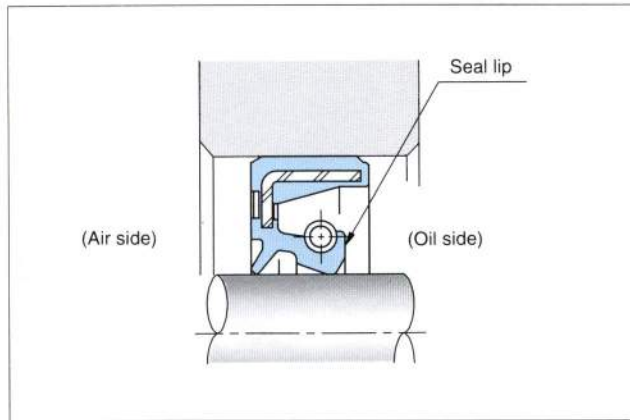

Figure 6 shows improper installation jig use. The oil seal will be deformed by the jig pressure and resistance of the seal/bore press-fit. When installing the oil seal, there is no need to apply force at the area near the lips.

Figure 6: Examples of Improperly Designed Assembly Jigs

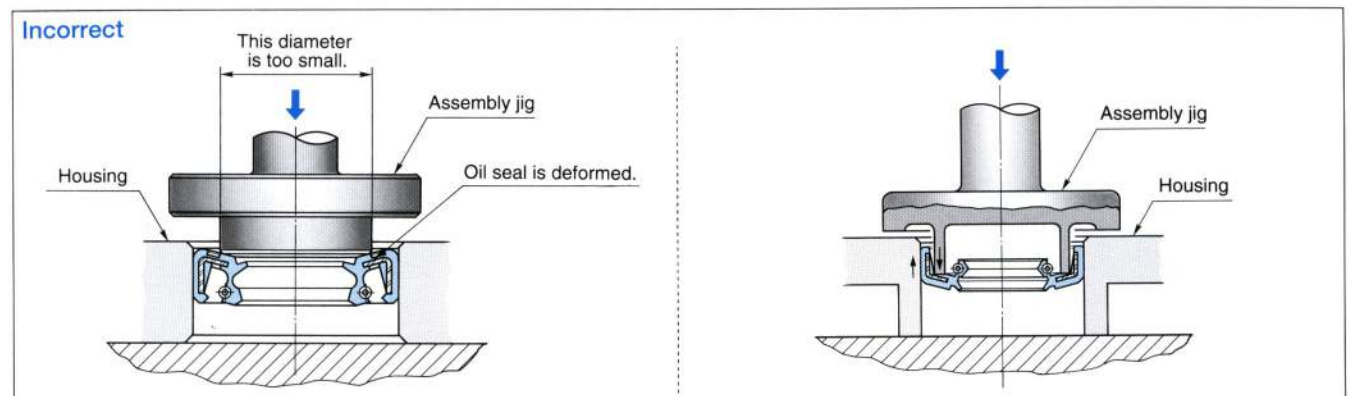
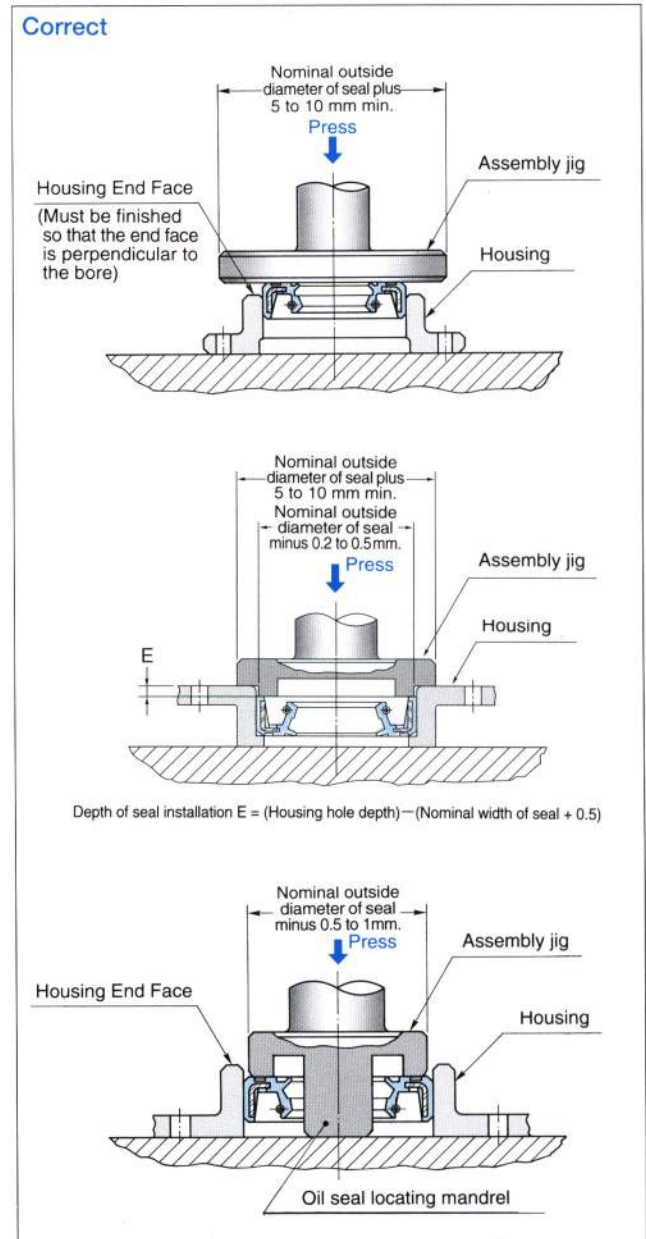
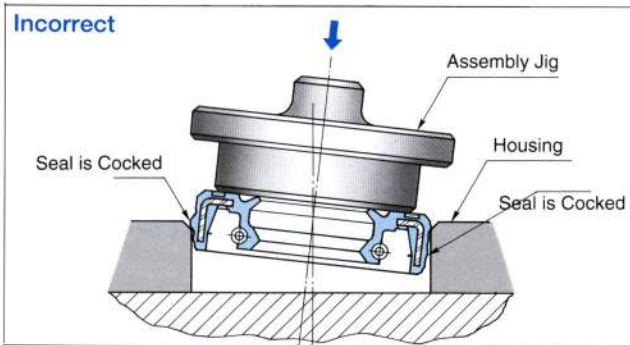

Figure 5: Use examples of assembling jig (applicable to the fit with rubber or metal)



- 3 Place the oil seal in the housing bore in a horizontal position, and then press the oil seal in uniformly. Pressing a cocked seal in with excessive force (see Fig. 7) deforms the oil seal, which in turn causes leakage.

Figure 7: A Cocked Seal Installation Example



- 4 For oil seals with a rubber OD, press the assembly jig twice in succession to let the oil seal settle firmly at the desired depth of installation in the bore.

- 5 If a press is not available, use a full-sized strike plate as shown in Figure 8, and drive the entire circumference evenly with a hammer to install the oil seal squarely into the bore. Do not strike the oil seal directly with a hammer, as shown in Figure 9.

- 6 Figure 10 shows the press forces required to properly install an oil seal.

Figure 8: Installing a Seal Without a Press

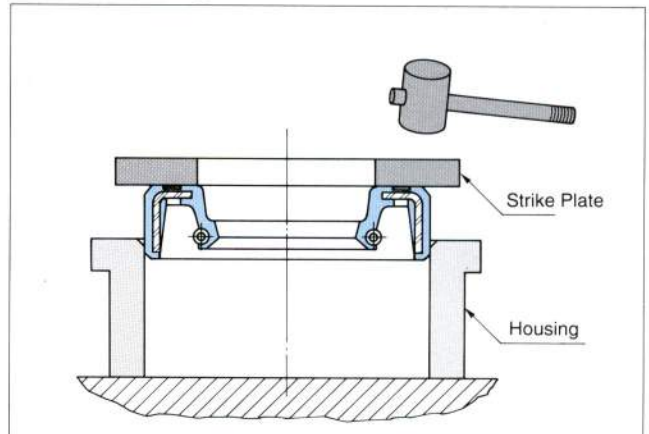

Figure 9: Damage Caused by Direct Hammer Strikes

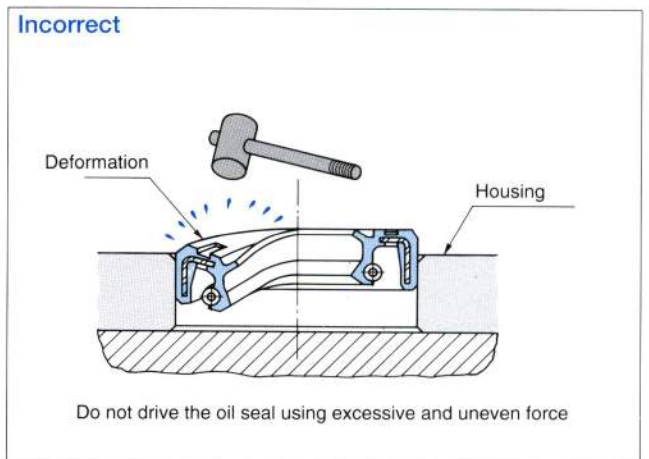
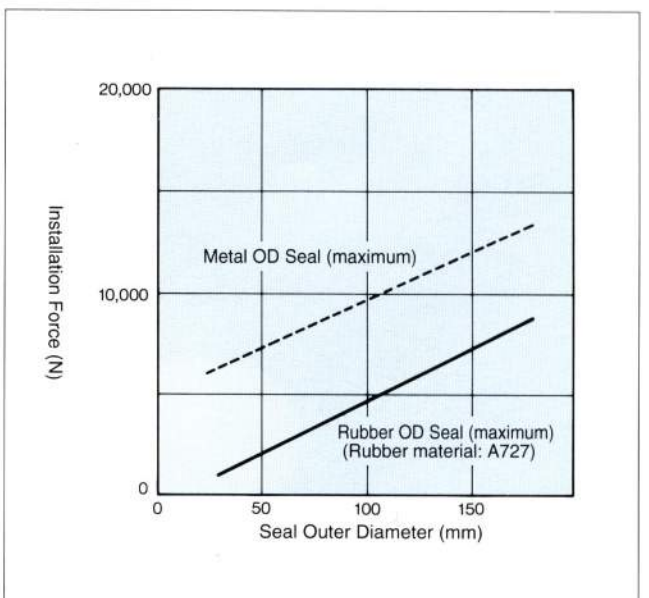

Figure 10: Seal Installation Force Requirements (a Guide)



(2) Assembly Into a Split-Type Housing

As mentioned on page F-14, avoid using a split-type housing if possible. If a split housing must be used, first assemble the housing, then install the seal in order to prevent cocking the seal.

Leaks can occur at the mating surface areas of the split housing. Apply a coat of liquid gasket sealant to the split area to prevent this leakage.

(3) Liquid Gasket Sealant

When a metal OD seal is used, it is necessary to apply a coat of liquid sealant to prevent the bore ID surface from developing flaws during oil seal replacement, or when a metal OD seal is used and the application is subjected to internal pressure. Observe the following precautions when using sealants.

- 1 Apply a thin coating of the sealant to the bore ID surface of the housing, and wipe off any excess. Leakage can occur if the lip or the shaft surface is contaminated with sealant.
- 2 Full-curing or extremely strong sealants require excessive force to remove the oil seal, usually resulting in damage to the housing. Always use semi-drying liquid gasket sealant.

6. Installing the Seal Onto the Shaft

- 1 Apply a thin coating of lubricant or mineral oil based lithium grease (for example, Sealube S1 made by NOK) to the shaft surface and the chamfer area. The seal should be smoothly inserted onto the shaft. Take care not to cause lip turn-under during this operation.
- 2 Align the center of the seal with the shaft centerline, and carefully insert the shaft into the oil seal.
- 3 When installing a pre-assembled housing and seal onto a shaft, or inserting a long shaft into a preassembled seal/housing, the seal lip can be damaged due to shaft contact during this awkward operation. See sketch (A) in **Figures 11 and 12**. Avoid this damage by installing the seal only after the shaft and housing are assembled. If this is impossible, use an installation guide for the housing or shaft, as illustrated by (B) in **Figures 11 and 12**.

Figure 11: Assembling a Heavy or Awkward Housing

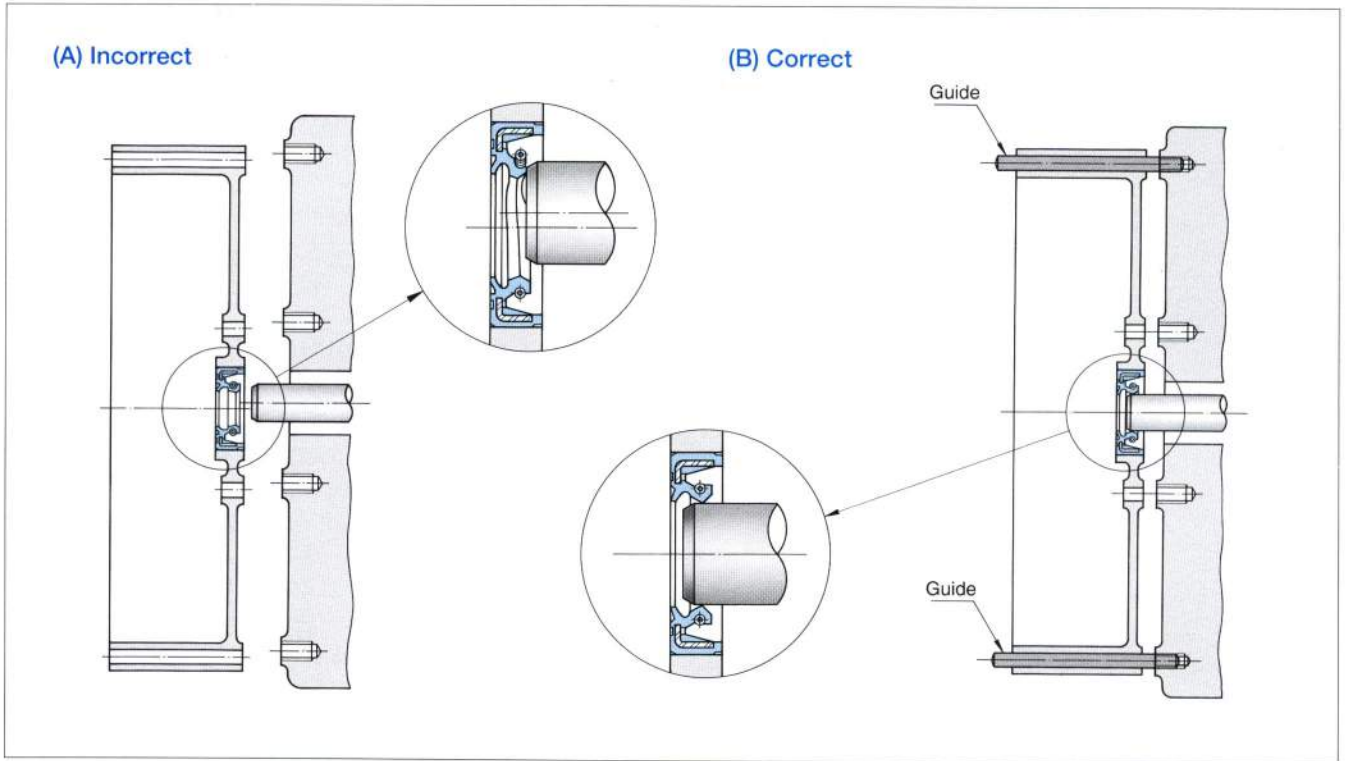

Note: When assembling a heavy housing by hand, as illustrated in (A), the shaft may come into contact with the lip and deform it, due to the difficulty of aligning the shaft and oil seal. For this reason, use a guide by taking advantage of the mounting bolt holes, as illustrated in (B).

Figure 12: Assembling a Long or Awkward Shaft

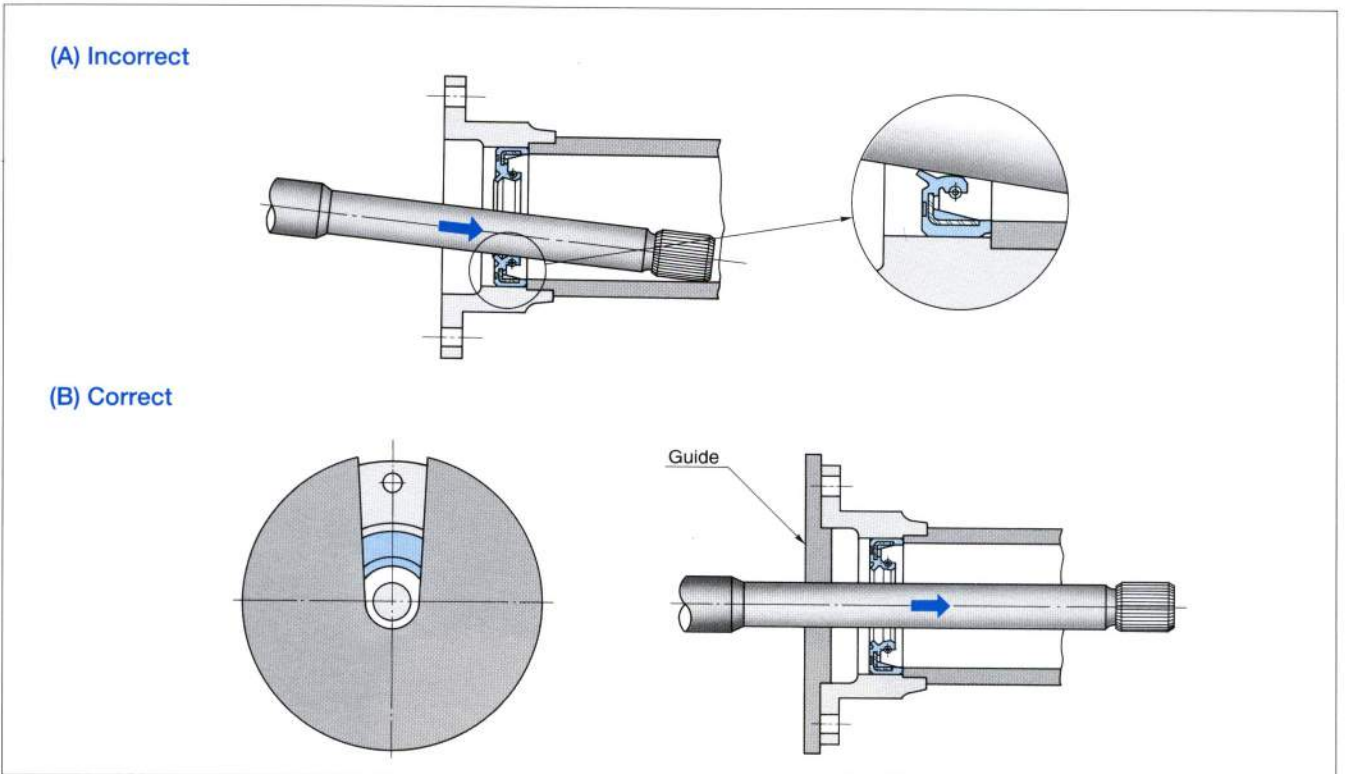

Note: If a guide is not used, part of the lip rubs against the shaft, damaging the sealing edge, as illustrated in (A). The use of the guide allows you to insert the shaft accurately, as illustrated in (B). Select a plastic guide to prevent the shaft surface from being scraped.

- ④ If the shaft has keyways or splines, the seal's lip edge may be damaged. Cover the shaft as illustrated in Fig. 13.

Figure 13: Protective Keyway/Spline Cover

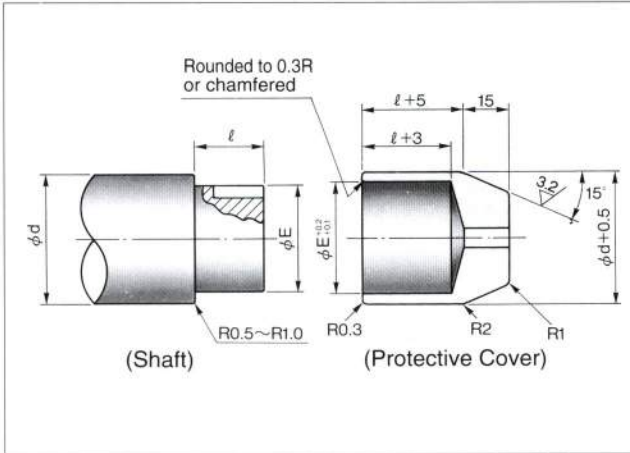

7. Oil Seal Replacement

- ① Always replace used oil seals when disassembling the oil seal area (i.e., removing the shaft).
- ② When removing an oil seal, take care not to damage the housing bore surface.
- ③ When replacing a new oil seal, place a 2mm shim in the housing hole in order to prevent the seal lip from riding in the same spot on the shaft as the previous seal.

8. Cleaning and Painting

- ① Cleaning the machine with oil or gasoline may cause the lip material of an exterior seal to swell, resulting in reduced seal performance.
- ② When painting the machine with an exterior seal, use care not to get paint on the oil seal or the shaft surface.

■ Handling NOK's General Oil Seals

The following explains how to handle general oil seals. Handle D-type oil seals in the same manner as standard oil seals.

J-Type (PTFE) Oil Seal

The sealing edge of a J type seal is more susceptible to installation damage than seals with standard synthetic rubber lips. Observe the following precautions when mounting J type oil seals onto the shaft.

- 1 Check that the shaft end is free of burrs or other defects.
- 2 Use an installation jig when there are keyways or splines on the shaft. (Refer to Fig. 8 on page G-8.)
- 3 Insert the shaft in the direction indicated in Fig. 14.

Figure 14: Shaft Assembly Direction

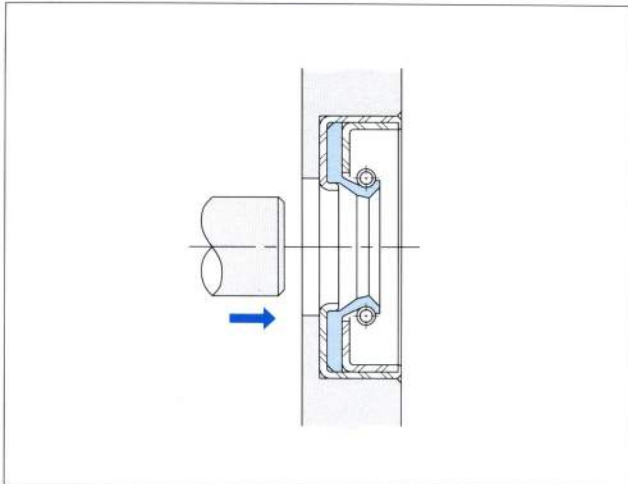

OC-Type Oil Seal

The seal lip and press-fit area of OC type seals are "inside out" (reversed) relative to those of standard oil seals. Nevertheless, handle this seal in the same manner as standard oil seals.

The lip is located on the outer circumference. Protect the outer peripheral lip during transit or storage.

QLFY-Type (With Integral Shaft) Oil Seal

The QLFY type seal has an integrated shaft (known as a unitized design). Mount this oil seal as a one-piece structure.

- 1 Use a jig as illustrated in Fig. 15 to press the QLFY seal into the housing bore.
- 2 Insert the shaft.

Figure 15: Mounting a QLFY-Type Seal

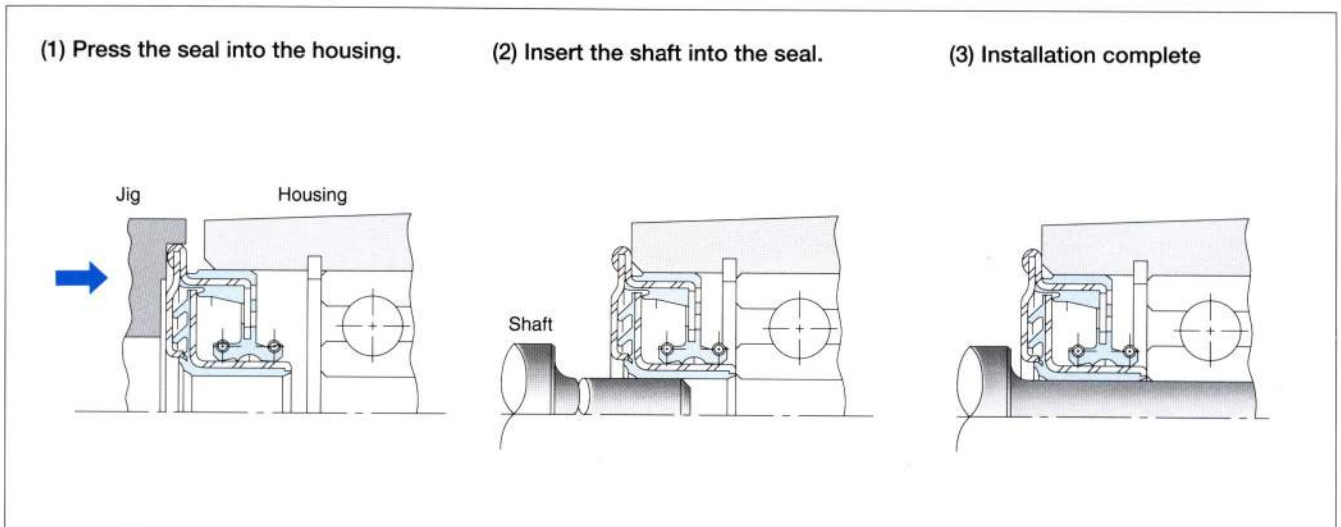

VR-Type (End Face) Seal

Mount the VR type seal so that the fluid to be sealed is outside the lip perimeter, as illustrated in Fig. 16. Apply a thin coating of grease to the sliding face of the lip before mounting. It is not necessary to put grease on the inner fixed face.

Figure 16: Proper Orientation of VR Type (End Face) Seals

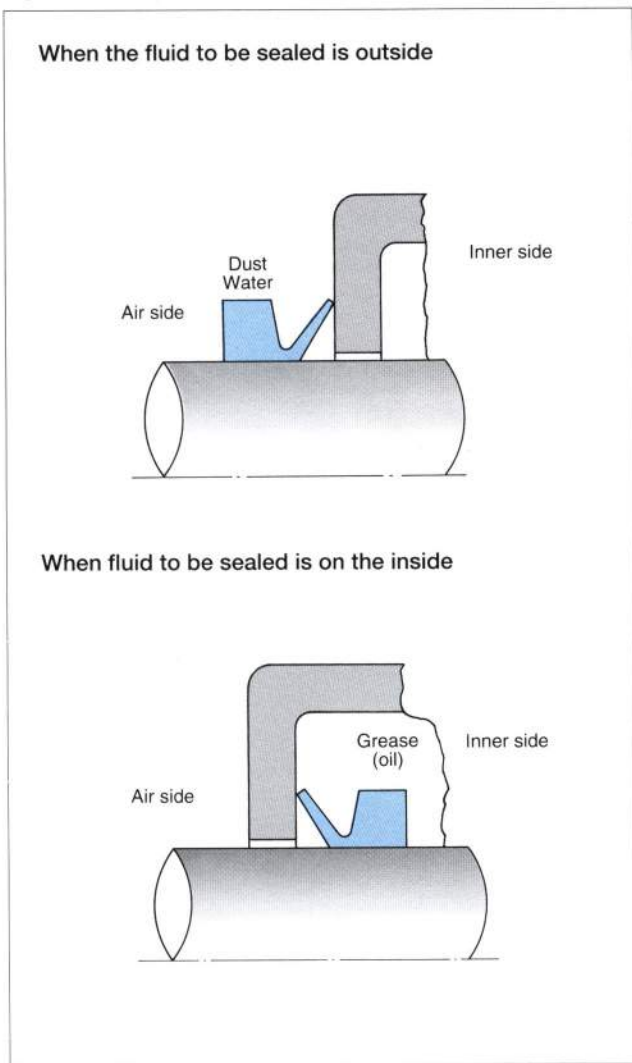

Z-Type Oil Seal

Mount the Z type seal into the grooves so that the perimeter of the oil seal is seated as evenly as possible. Do not apply a coating of grease or oil to the trapezoidal grooves of the housing or the OD of the oil seal.

After the oil seal is mounted in the housing grooves, apply a light coat of grease to the seal lip, and then assemble the structure onto the shaft.

SBB, Large-Diameter SB, Large-Diameter TB Type Oil Seals

① Assembly Into the Housing

Insert the entire circumference of the oil seal evenly by using a jig, as illustrated in Fig. 17.

Figure 17: Seal Installation

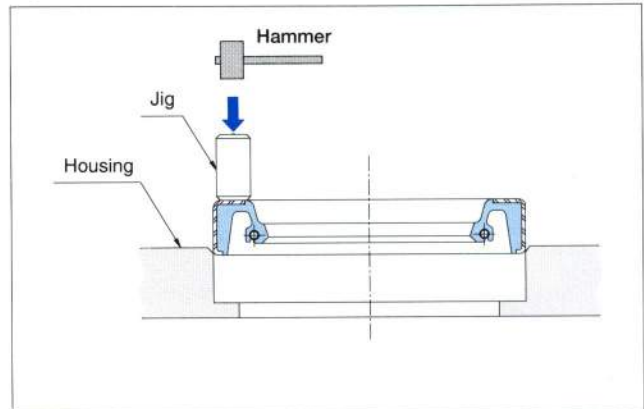

② Installing the Shaft

Apply a coat of oil or grease to the shaft surface to facilitate shaft installation and for initial lubrication. Use a jig as illustrated in Figure 18 when there are keyways or splines on the shaft, or when the shaft end cannot be chamfered properly.

Figure 18: Shaft Installation

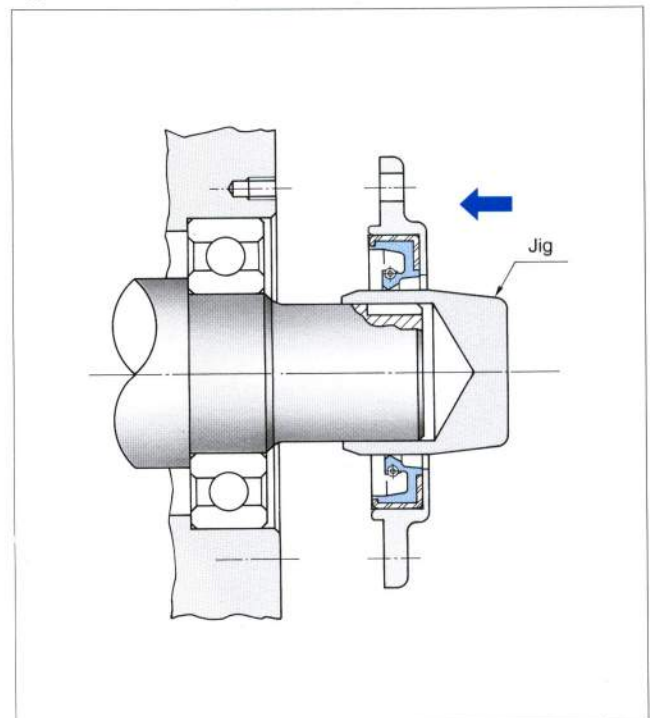

Installing an MG-Type Oil Seal

An MG type oil seal (Fig. 19) is installed after it is cut through its OD, giving it flexibility to be used where a full-round seal cannot. Cut the oil seal as illustrated in Fig. 20. Connect the hooks of the garter spring, then put the garter spring in the lip pocket.

Observe the following precautions when assembling an MG type oil seal.

- 1 Place the cut splice side of the oil seal at the top.
- 2 Rotate the garter spring hook 45 degrees from the splice cut.
- 3 Adjust the spliced ends as evenly as possible. Do not apply any liquid sealant to the splice joint.
- 4 Place the pressure plate and tighten the bolts evenly. If the pressure plate is a split-type design, stagger the split lines 90 degrees to the seal splice.

OKC3, MO, MOY Type Oil Seals

OKC3, MO, and MOY type oil seals are designed to seal by its outer diameter surfaces. Use care not to deform the outer lips or damage the sealing edges during transit or storage.

- 1 Do not transport the oil seal by rolling it.
- 2 Do not store the oil seal standing on its edges or leaning it against something.

Figure 19: MG Type Oil Seal



Figure 20: Cutting the MG Seal

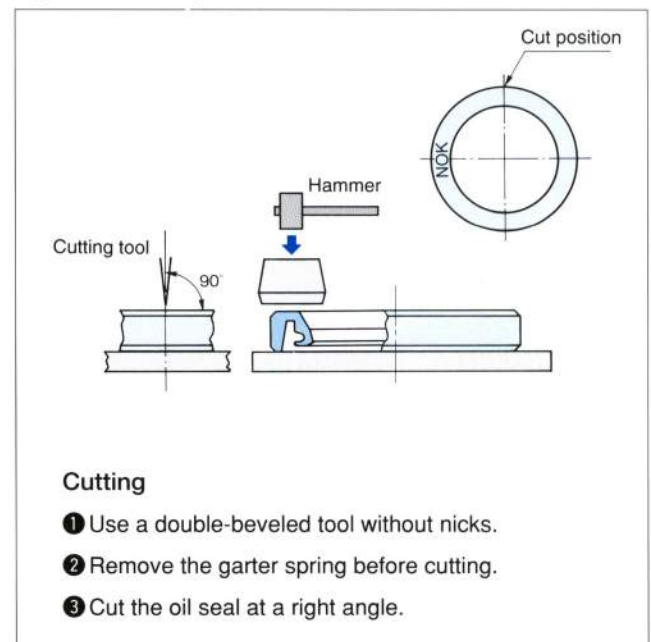

TO ORDER NOK OIL SEALS

Contact your nearest NOK sales office or agent.

- 1.** Please indicate the NOK part number and dimensions.
- 2.** Consult us when you need an oil seal not listed in this catalog, or if you are not sure which product to select for special working conditions.
- 3.** A quote will be provided to you for oil seals not listed in the catalog, or when you require a standard-dimension seals made from non-standard materials (e.g., rubber, metal case, garter spring).

Note: The cross-sectional shape of each oil seal listed in this catalog is shown with the standard profile.



Type & Size List of NOK Oil Seals

NOK Standard Oil Seals (shaft diameter 300 mm or smaller)

1. SC type, SB type	Nitrile rubber (NBR) oil seal	H- 2
	Acrylic rubber (ACM) oil seal	H-15
	Silicone rubber (VMQ) oil seal	H-18
	Fluorocarbon rubber (FKM) oil seal	H-21
2. TC type, TB type	Nitrile rubber (NBR) oil seal	H-25
	Acrylic rubber (ACM) oil seal	H-36
	Silicone rubber (VMQ) oil seal	H-39
	Fluorocarbon rubber (FKM) oil seal	H-42
3. TCK type (new fabric seal)	Nitrile rubber (NBR) oil seal	H-45
4. VC type, VB type	Nitrile rubber (NBR) oil seal	H-47
5. KC type, KB type	Nitrile rubber (NBR) oil seal	H-53
6. TCV type, TCN type	Nitrile rubber (NBR) oil seal	H-55
	Fluorocarbon rubber (FKM) oil seal	H-58
7. TC4 type, TB4 type	Nitrile rubber (NBR) oil seal	H-60

NOK General Oil Seals

8. TCJ type for CFCs (PTFE seal)	Nitrile rubber (NBR) and Acrylic rubber (ACM) oil seal	H-63
9. SA1J type, VAJ type, KA3J type	Rare CFCs (PTFE) oil seal	H-65
10. DC type, DB type	Nitrile rubber (NBR) and Acrylic rubber (ACM) oil seal	H-67
11. OC type	Nitrile rubber (NBR) oil seal	H-69
12. QLFY type	Nitrile rubber (NBR) oil seal	H-71
13. VR type	Nitrile rubber (NBR) and Fluorocarbon rubber (FKM) oil seal	H-73
14. ZF type, ZT type	Nitrile rubber (NBR) oil seal	H-77
15. SBB type, Large-diameter SB type	Nitrile rubber (NBR) oil seal	H-81
16. Large-diameter TB type	Nitrile rubber (NBR) oil seal	H-86
17. MG type	Nitrile rubber (NBR) oil seal	H-88
18. WT type, WTT type	Nitrile rubber (NBR) oil seal	H-92
19. OKC3 type	Nitrile rubber (NBR) oil seal	H-95
20. MO type (Mogoil seal)	Nitrile rubber (NBR) oil seal	H-97
21. MOY type (Meseta seal)	Nitrile rubber (NBR) and Acrylic rubber (ACM) oil seal	H-99

NOK Standard Oil Seals

SC Type, SB Type

Nitrile rubber (NBR) oil seals



- When ordering, please indicate the NOK part number and the relevant dimensions.
- Check the Guide to Allowable Operating Conditions on pages E-6 and E-7 for relevant information on the seal selected before use.

Lip Material	NOK A727: Shaft diameter class 150 mm or smaller NOK A941: Shaft diameter class 150 mm or larger
--------------	---

SC Type, SB Type

Material Nitrile (NBR)

● The sectional view on the right shows the typical profile of the seal type.

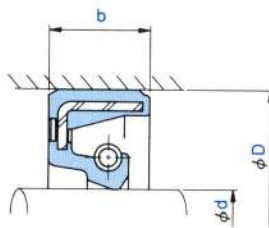

SC type

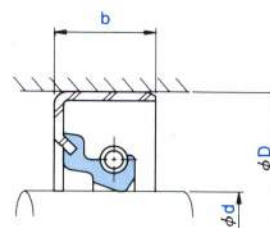

SB type

Shaft diameter d	Dimensions		Part Number	Part Number
	Outside diameter D	Width b		
6	16	7	AC 0052 E3	—
7	18	7	AC 0087 E0	—
7	20	7	AC 0090 A0	AB 0090 E0
8	18	7	AC 0145 E0	AB 0145 E0
8	18	9	—	AB 0147 F0
8	22	7	AC 0158 A8	AB 0158 E0
9	22	7	AC 0205 A0	AB 0205 E0
10	20	7	AC 0260 H0	AB 0260 E0
10	21	8	AC 0267 E0	AB 0267 E0
10	22	8	AC 0271 E0	AB 0271 F0
10	25	7	AC 0279 A0	AB 0279 E0
10	26	8	AC 0283 E0	—
10	28	8	AC 0285 E0	—
10	30	7	AC 0288 E0	AB 0288 E0
11	22	7	AC 0308 E1	AB 0308 E2
11	25	7	AC 0311 E0	AB 0311 E1
11	30	7	AC 0314 E0	—
12	22	7	AC 0371 E0	AB 0371 E0
12	25	7	AC 0382 A0	AB 0382 E0
12	28	7	AC 0387 E0	AB 0387 E0
12	30	9	AC 0393 E0	AB 0393 E0
12	32	6	—	AB 0398 E0
13	25	7	AC 0473 F0	AB 0473 E1
13	28	7	AC 0478 A0	AB 0478 E0
13	30	8	AC 0483 E1	—
14	24	6	AC 0514 E0	AB 0514 E0
14	25	7	AC 0519 E0	AB 0519 E1
14	28	7	AC 0526 A0	AB 0526 E0
14	32	9	AC 0536 E0	—
15	24	7	AC 0584 E1	AB 0584 E0
15	25	7	AC 0588 E5	AB 0588 F0
15	28	7	AC 0592 E1	AB 0592 E0
15	30	7	AC 0598 A0	AB 0598 E0
15	32	7	AC 0603 E0	AB 0603 E0
15	32	9	AC 0604 E0	AB 0604 E0
15	34	10	AC 0606 E0	—
15	35	7	AC 0610 F3	AB 0610 E0
15	35	8	AC 0611 E0	—
15	37	7	AC 0616 E0	—
16	26	7	AC 0678 E0	AB 0678 E0

SC Type, SB Type

Material Nitrile (NBR)

● The sectional view on the right shows the typical profile of the seal type.

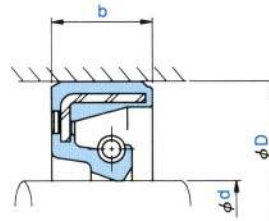

SC type

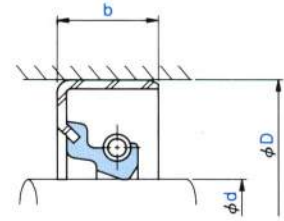

SB type

Dimensions			Part Number	Part Number
Shaft diameter d	Outside diameter D	Width b		
16	28	6	AC 0684 E1	—
16	28	7	AC 0685 F0	AB 0685 E0
16	30	7	AC 0687 A0	AB 0687 E0
16	32	8	AC 0691 E0	—
16	35	9	—	AB 0698 E0
17	28	7	—	AB 0736 F0
17	30	6	AC 0742 E0	AB 0742 G0
17	30	7	AC 0743 E0	—
17	30	8	AC 0745 E0	AB 0745 G0
17	32	7	AC 0750 E1	—
17	32	8	—	AB 0751 E0
17	35	6	AC 0758 E0	—
17	35	7	AC 0759 H0	AB 0759 E0
17	35	8	AC 0760 A0	—
17	38	7	AC 0768 E1	AB 0768 E0
17	40	8	AC 0771 F0	AB 0771 E1
17	40	10	AC 0773 E0	—
18	30	7	AC 0816 E0	AB 0816 E0
18	30	8	AC 0817 E0	AB 0817 E0
18	32	9	AC 0825 E0	—
18	35	7	AC 0828 E0	—
18	35	8	AC 0829 A0	AB 0829 E0
18	35	9	—	AB 0831 E0
18	38	7	AC 0838 E0	—
19	30	8	AC 0864 F0	AB 0864 E0
19	35	8	AC 0875 A0	—
19	38	7	—	AB 0880 E0
19	38	10	—	AB 0881 E0
19	40	10	AC 0883 E0	AB 0883 E0
20	30	7	AC 0984 E0	AB 0984 H0
20	30	9	AC 0987 E0	AB 0987 E0
20	32	8	AC 0997 E0	AB 0997 E0
20	34	7	AC 1003 E1	—
20	35	7	AC 1012 E0	AB 1012 E0
20	35	8	AC 1013 A0	AB 1013 E0
20	36	7	AC 1017 E0	AB 1017 F0
20	36	10	—	AB 1019 E0
20	40	7	AC 1029 E0	AB 1029 E0
20	40	8	AC 1030 E0	AB 1030 E3
20	40	10	AC 1032 F0	AB 1032 E0

SC Type, SB Type

Material Nitrile (NBR)

● The sectional view on the right shows the typical profile of the seal type.

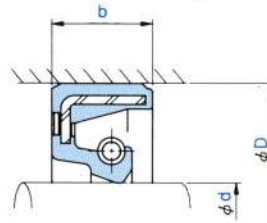

SC type

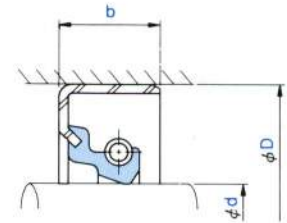

SB type

Dimensions			Part Number	Part Number
Shaft diameter d	Outside diameter D	Width b		
20	40	11	AC 1033 A0	AB 1033 F0
20	42	10	AC 1038 E0	AB 1038 E0
20	45	12	AC 1045 E0	AB 1045 E0
20	47	7	AC 1048 E0	—
21	35	7	AC 1084 E1	AB 1084 E0
22	32	7	AC 1116 E3	AB 1116 E0
22	35	7	AC 1126 F0	AB 1126 E0
22	35	8	AC 1127 E0	AB 1127 E0
22	36	10	AC 1130 E0	AB 1130 E0
22	37	8	AC 1131 E0	—
22	38	8	AC 1133 E0	AB 1133 E0
22	38	12	AC 1136 E0	—
22	40	8	AC 1138 E0	AB 1138 E1
22	40	10	AC 1140 E0	AB 1140 E0
22	42	7	AC 1145 E0	AB 1145 E0
22	42	10	AC 1147 E0	—
22	42	11	AC 1148 A0	AB 1148 E0
23	32	7	AC 1213 P1	—
23	42	7	—	AB 1223 E0
23	42	11	AC 1224 A0	AB 1224 E0
24	38	7	AC 1251 E0	—
24	38	8	AC 1252 E0	AB 1252 E0
24	38	10	—	AB 1255 E0
24	40	7	AC 1259 E0	—
24	40	8	AC 1260 A0	AB 1260 E0
24	45	7	—	AB 1265 E0
25	35	6	AC 1292 G0	—
25	37	8	AC 1302 F0	AB 1302 F0
25	38	7	AC 1306 E0	AB 1306 E0
25	38	8	—	AB 1307 E0
25	40	8	AC 1314 A0	AB 1314 F0
25	40	10	AC 1315 E0	AB 1315 E0
25	42	8	AC 1322 E0	AB 1322 E0
25	42	10	AC 1324 E0	—
25	42	11	AC 1325 E0	—
25	44	7	AC 1327 F0	—
25	45	7	AC 1334 E0	—
25	45	8	AC 1335 E0	AB 1335 F0
25	45	10	—	AB 1337 F0
25	45	11	AC 1338 A7	AB 1338 E0



SC Type, SB Type

Material Nitrile (NBR)

● The sectional view on the right shows the typical profile of the seal type.

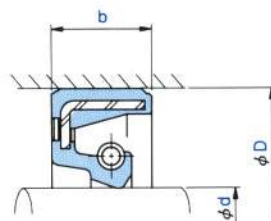

SC type

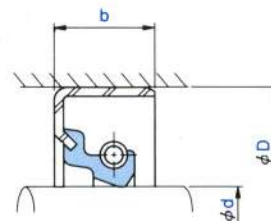

SB type

Shaft diameter d	Dimensions		Part Number	Part Number
	Outside diameter D	Width b		
25	47	6	AC 1348 E1	AB 1348 E0
25	47	7	AC 1350 E0	—
25	47	10	—	AB 1352 E0
25	48	8	AC 1357 E0	—
25	50	9	AC 1361 E0	AB 1361 E0
25	50	12	—	AB 1363 E0
25	52	8	AC 1374 E2	—
25	52	10	—	AB 1377 E0
25	52	12	—	AB 1379 E0
26	36	8	—	AB 1459 E0
26	38	8	AC 1464 E0	AB 1464 E0
26	40	8	AC 1468 E0	AB 1468 E0
26	42	8	AC 1474 A0	AB 1474 F0
27	40	8	—	AB 1508 E0
27	42	8	AC 1511 E0	—
27	43	9	AC 1512 E0	AB 1512 E0
27	47	11	AC 1518 A0	AB 1518 E0
28	38	7	AC 1531 F0	AB 1531 E0
28	38	8	—	AB 1532 E1
28	40	8	AC 1538 F0	AB 1538 E0
28	42	8	AC 1544 E0	AB 1544 E0
28	44	8	AC 1545 E0	—
28	44	11	AC 1546 E0	AB 1546 G1
28	45	8	AC 1550 E0	AB 1550 E0
28	48	11	AC 1563 A0	AB 1563 E0
28	50	8	AC 1569 E0	—
28	50	10	AC 1570 E0	—
30	39	7	—	AB 1651 F0
30	40	7	—	AB 1656 E0
30	42	8	AC 1666 E2	AB 1666 E0
30	44	9	AC 1673 E0	AB 1673 E0
30	45	7	AC 1677 E1	—
30	45	8	AC 1679 A0	AB 1679 G0
30	45	9	—	AB 1680 E0
30	45	11	AC 1681 E0	—
30	45	12	AC 1682 E0	AB 1682 E0
30	46	9	AC 1689 E0	AB 1689 E0
30	47	8	AC 1692 E0	AB 1692 F0
30	47	10	—	AB 1693 E0
30	47	12	—	AB 1695 E0

SC Type, SB Type

Material Nitrile (NBR)

● The sectional view on the right shows the typical profile of the seal type.

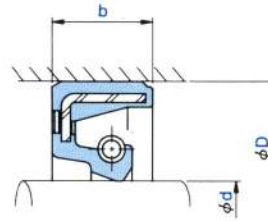

SC type

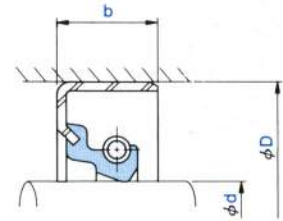

SB type

Dimensions			Part Number	Part Number
Shaft diameter d	Outside diameter D	Width b		
30	48	8	AC 1700 E0	AB 1700 E0
30	48	11	AC 1702 E0	AB 1702 E0
30	50	7	AC 1704 E0	AB 1704 F0
30	50	8	—	AB 1705 F0
30	50	9	AC 1706 E0	AB 1706 E0
30	50	10	AC 1708 E0	AB 1708 E0
30	50	11	AC 1709 A0	AB 1709 G0
30	52	7	AC 1719 E0	—
30	52	10	AC 1721 E0	AB 1721 E0
30	55	12	—	AB 1736 E0
31	47	7	AC 1797 E1	—
31	50	8	AC 1799 E0	—
32	43	10	—	AB 1869 E0
32	44	9	AC 1871 G1	AB 1871 E0
32	45	8	AC 1880 E0	AB 1880 E0
32	46	8	AC 1884 E0	AB 1884 E0
32	47	8	—	AB 1888 F0
32	48	7	AC 1893 E0	—
32	48	8	—	AB 1894 E0
32	51	10	AC 1898 E0	—
32	52	8	AC 1902 E0	AB 1902 E0
32	52	11	AC 1904 A0	AB 1904 E0
33	50	7	AC 1933 E0	AB 1933 E0
33	50	8	AC 1934 E0	—
33	52	7	AC 1937 E0	AB 1937 E0
33	56	12	AC 1939 E0	—
34	48	8	AC 1968 G1	AB 1968 E0
34	50	7	AC 1971 E0	—
34	54	11	AC 1978 A0	AB 1978 E0
35	47	7	AC 2041 E0	AB 2041 F0
35	48	8	AC 2048 E0	AB 2048 E0
35	50	7	AC 2056 E0	AB 2056 E0
35	50	8	AC 2057 A0	AB 2057 G0
35	50	10	—	AB 2059 E0
35	50	11	AC 2060 E0	—
35	52	7	AC 2066 E0	AB 2066 E0
35	52	8	AC 2067 E0	—
35	52	9	AC 2068 E0	—
35	52	10	AC 2069 E0	AB 2069 E0
35	52	12	—	AB 2072 F0

SC Type, SB Type

Material Nitrile (NBR)

● The sectional view on the right shows the typical profile of the seal type.

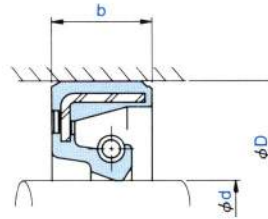

SC type

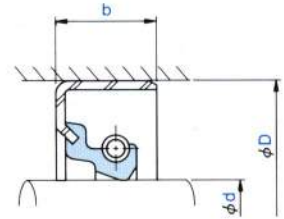

SB type

Dimensions			Part Number	Part Number
Shaft diameter d	Outside diameter D	Width b		
35	55	8	AC 2081 E0	AB 2081 E0
35	55	9	—	AB 2083 F0
35	55	11	AC 2085 A0	AB 2085 F0
35	56	10	AC 2094 E0	—
35	58	9	AC 2099 E0	AB 2099 E1
35	60	8	AC 2103 E1	—
35	60	12	AC 2107 E0	AB 2107 F0
35	62	10	AC 2118 E0	AB 2118 E0
35	62	12	AC 2121 E0	—
36	50	7	AC 2162 E0	AB 2162 E0
36	50	10	—	AB 2164 E0
36	54	8	AC 2166 E0	—
37	62	12	AC 2204 E0	—
38	47	10	—	AB 7101 E0
38	50	8	AC 2218 E0	AB 2218 E1
38	55	8	AC 2230 E0	AB 2230 E0
38	55	9	AC 2231 E0	AB 2231 E0
38	56	10	AC 2233 E1	—
38	58	7	—	AB 2238 E0
38	58	8	AC 2239 E0	AB 2239 E2
38	58	11	AC 2240 A7	AB 2240 G0
38	62	11	AC 2250 E0	AB 2250 E0
40	52	8	AC 2343 E4	AB 2343 E3
40	55	7	AC 2358 E1	—
40	55	8	AC 2359 E0	—
40	55	9	AC 2361 E0	AB 2361 G0
40	55	10	AC 2362 E0	—
40	56	8	AC 2365 E0	—
40	58	7	AC 2368 E0	—
40	58	8	AC 2369 A0	AB 2369 F0
40	60	8	AC 2375 E0	AB 2375 E0
40	60	10	AC 2377 E0	AB 2377 E0
40	60	12	—	AB 2379 F0
40	62	7	AC 2385 E0	AB 2385 E0
40	62	8	AC 2386 E0	AB 2386 E0
40	62	11	AC 2388 A0	AB 2388 F0
40	62	12	AC 2390 E0	AB 2390 H0
40	65	10	AC 2402 E0	AB 2402 E0
40	65	12	AC 2403 E0	AB 2403 E0
40	65	14	AC 2405 E0	—

SC Type, SB Type

Material Nitrile (NBR)

● The sectional view on the right shows the typical profile of the seal type.

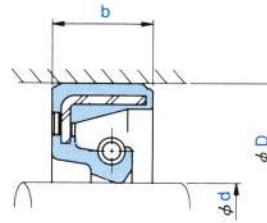

SC type

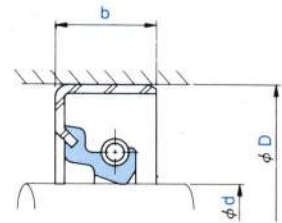

SB type

Dimensions			Part Number	Part Number
Shaft diameter d	Outside diameter D	Width b		
42	55	9	—	AB 2483 E0
42	58	10	AC 2491 E0	—
42	60	9	AC 2493 E0	AB 2493 F0
42	60	12	—	AB 2495 E0
42	62	10	AC 2499 E0	—
42	65	9	AC 2504 E0	AB 2504 E0
42	65	12	AC 2507 A0	AB 2507 E0
43	52	10	—	BB 2041 E0
43	60	10	AC 2539 E0	—
44	56	7	—	AB 2551 E0
45	60	7	—	AB 2641 E0
45	60	9	AC 2643 E0	AB 2643 F0
45	61	9	—	AB 2647 G0
45	62	9	AC 2651 A8	AB 2651 F0
45	62	10	AC 2652 E0	AB 2652 E0
45	62	12	AC 2653 E0	AB 2653 E0
45	65	10	AC 2658 E0	AB 2658 E0
45	65	12	AC 2659 E0	—
45	68	9	AC 2666 E0	AB 2666 F0
45	68	10	AC 2667 E0	—
45	68	12	AC 2668 A0	AB 2668 F0
45	70	12	AC 2676 E0	—
45	70	14	AC 2677 E0	AB 2677 E0
45	72	10	AC 2684 E0	—
45	72	12	AC 2685 E0	AB 2685 E0
46	65	9	AC 2717 E0	—
47	70	12	AC 2735 E0	AB 2735 E0
48	62	9	—	AB 2775 E0
48	65	9	AC 2780 E0	AB 2780 G0
48	68	10	AC 2785 E0	—
48	70	9	AC 2788 E0	AB 2788 E0
48	70	12	AC 2791 A0	AB 2791 E0
50	64	10	—	AB 2834 E0
50	65	9	AC 2838 G2	AB 2838 E0
50	68	9	AC 2847 E0	AB 2847 G0
50	68	10	AC 2848 E0	—
50	70	10	AC 2854 E0	AB 2854 G0
50	70	12	AC 2857 E0	AB 2857 E0
50	72	9	AC 2861 E0	AB 2861 E0
50	72	10	—	AB 2862 E0

SC Type, SB Type

Material Nitrile (NBR)

● The sectional view on the right shows the typical profile of the seal type.

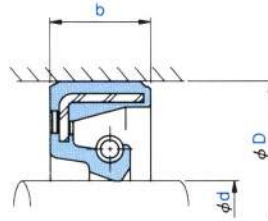

SC type

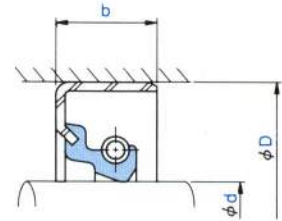

SB type

Dimensions			Part Number	Part Number
Shaft diameter d	Outside diameter D	Width b		
50	72	12	AC 2864 K0	AB 2864 G0
50	72	13	AC 2865 E0	—
50	74	12	AC 2872 E0	AB 2872 E0
50	80	10	—	AB 2886 E0
50	80	12	AC 2887 E0	AB 2887 F0
50	80	14	AC 2888 E0	AB 2888 E0
51	62	7	—	AB 8924 E1
52	70	9	AC 2959 E0	AB 2959 F0
52	72	10	AC 2961 E0	—
52	75	9	AC 2965 E0	AB 2965 E0
52	75	12	AC 2967 A5	AB 2967 E0
54	72	12	AC 3014 E0	AB 3014 E1
54	82	10	AC 3021 E1	—
55	70	9	AC 3036 E0	AB 3036 F0
55	72	9	AC 3040 A0	AB 3040 G0
55	78	9	AC 3053 E1	AB 3053 E0
55	78	12	AC 3055 A0	AB 3055 J0
55	80	12	AC 3062 E0	AB 3062 E0
55	85	14	AC 3072 E0	AB 3072 F0
56	78	12	AC 3094 E0	AB 3094 E0
57	78	10	AC 3107 E1	—
58	75	9	AC 3148 E0	AB 3148 E0
58	80	9	AC 3152 E0	AB 3152 G0
58	80	12	AC 3154 A9	AB 3154 E0
60	75	9	AC 3193 E2	AB 3193 F0
60	75	10	—	AB 3195 F0
60	78	9	AC 3204 E0	AB 3204 F0
60	80	10	AC 3211 E0	AB 3211 E0
60	80	12	AC 3213 E0	AB 3213 E0
60	82	9	AC 3220 E0	AB 3220 E0
60	82	12	AC 3222 A0	AB 3222 G0
60	85	12	AC 3234 E0	AB 3234 E0
60	90	14	—	AB 3244 E0
62	80	9	AC 3290 E0	AB 3290 F0
62	85	9	AC 3295 E0	—
62	85	12	AC 3297 A0	AB 3297 E0
63	80	9	AC 3316 E0	AB 3316 E0
63	85	9	—	AB 3320 E0
63	85	12	AC 3321 E0	AB 3321 E1
65	82	10	AC 3389 E0	AB 3389 E0

SC Type, SB Type

Material Nitrile (NBR)

● The sectional view on the right shows the typical profile of the seal type.

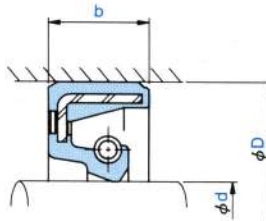

SC type

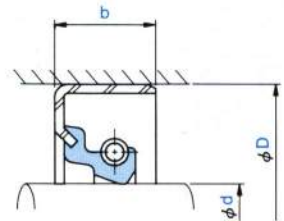

SB type

Shaft diameter d	Dimensions		Part Number	Part Number
	Outside diameter D	Width b		
65	82	12	AC 3390 E0	—
65	85	10	AC 3394 E1	—
65	85	12	AC 3395 E0	AB 3395 E0
65	88	12	AC 3400 A0	AB 3400 F0
65	90	10	AC 3406 E0	AB 3406 E0
65	90	12	AC 3408 E0	—
65	90	13	AC 3409 A0	AB 3409 F0
65	95	12	AC 3413 E0	—
65	95	14	AC 3414 F0	AB 3414 E0
66	86	10	AC 3427 E0	—
67	90	10	AC 3451 E0	—
68	90	12	AC 3459 A4	AB 3459 F0
68	95	13	AC 3463 E0	AB 3463 E0
70	88	12	AC 3505 E0	AB 3505 E0
70	90	10	—	AB 3512 E0
70	90	12	AC 3513 E1	AB 3513 E0
70	92	12	AC 3519 A0	AB 3519 G0
70	95	13	AC 3527 A0	AB 3527 G0
70	100	10	—	AB 3530 E0
70	100	14	AC 3532 E0	AB 3532 G0
71	95	13	AC 3549 E1	AB 3549 E0
72	100	12	AC 3562 E0	AB 3562 G0
75	100	13	AC 3618 E0	AB 3618 H0
75	105	12	AC 3628 E0	AB 3628 E0
75	105	15	AC 3631 E0	AB 3631 E0
80	100	9	AC 3731 E0	—
80	100	10	AC 3732 E1	AB 3732 E0
80	100	13	—	AB 3734 E0
80	105	13	AC 3744 A0	AB 3744 H0
80	115	15	AC 3761 E0	AB 3761 F0
82	105	13	AC 3786 E0	AB 3786 E0
85	105	15	—	AB 3837 E0
85	110	13	AC 3842 G0	AB 3842 H0
85	120	15	AC 3855 E0	AB 3855 E0
88	115	13	AC 3879 E0	AB 3879 E0
90	110	13	—	AB 3921 E0
90	115	13	AC 3932 A0	AB 3932 H0
90	115	15	—	AB 3934 E0
90	120	13	AC 3938 E0	AB 3938 E0
90	125	15	AC 3944 E0	AB 3944 E0

SC Type, SB Type

Material Nitrile (NBR)

● The sectional view on the right shows the typical profile of the seal type.

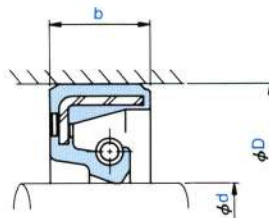

SC type

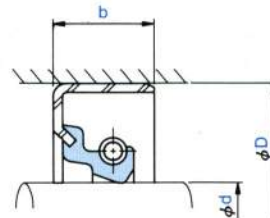

SB type

Dimensions			Part Number	Part Number
Shaft diameter d	Outside diameter D	Width b		
90	130	13	—	AB 3948 E0
95	115	13	—	AB 3984 E0
95	120	13	AC 3994 E0	AB 3994 F0
95	125	14	—	AB 4000 E0
95	130	15	AC 4007 E0	AB 4007 E0
98	120	15	—	AB 4033 E0
100	120	12	—	AB 4055 E0
100	120	13	—	AB 4056 E0
100	125	13	AC 4063 G2	AB 4063 A0
100	125	15	—	AB 4065 E0
100	130	13	—	AB 4073 E1
100	130	15	—	AB 4074 E0
105	125	15	—	AB 4146 E0
105	130	13	—	AB 4150 E0
105	135	14	AC 4153 F0	AB 4153 E0
105	140	15	—	AB 4161 E0
110	140	14	AC 4212 E0	AB 4212 E0
110	140	15	—	AB 4213 E0
110	145	14	—	AB 4220 E0
110	145	15	—	AB 4221 E0
112	145	14	—	AB 4237 F0
115	145	14	AC 4282 F0	AB 4282 A0
115	150	16	—	AB 4292 E0
120	140	13	—	AB 4330 E1
120	150	14	AC 4346 F0	AB 4346 A0
120	155	16	AC 4355 E0	AB 4355 E0
125	155	14	AC 4399 E1	AB 4399 A0
125	160	16	AC 4404 E0	AB 4404 E0
128	153	18	—	AB 4433 E0
130	160	14	AC 4451 F2	AB 4451 A0
130	160	15	—	AB 4452 E0
130	160	16	—	AB 4453 E0
130	170	15	—	AB 4464 E0
130	170	16	AC 4465 E0	AB 4465 E0
135	165	14	AC 4498 E0	AB 4498 E0
135	170	15	—	AB 4503 E0
140	170	14	AC 4542 E0	AB 4542 A0
140	185	16	AC 4558 E0	AB 4558 E0
145	175	14	AC 4581 E0	AB 4581 A0
145	190	16	AC 4588 E0	AB 4588 E0

SC Type, SB Type

Material Nitrile (NBR)

● The sectional view on the right shows the typical profile of the seal type.

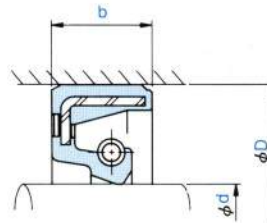

SC type

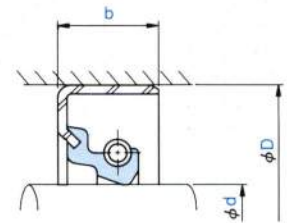

SB type

Shaft diameter d	Dimensions		Part Number	Part Number
	Outside diameter D	Width b		
150	180	14	AC 4624 E1	AB 4624 A0
150	195	20	—	AB 4635 E0
155	180	15	—	AB 4666 E0
155	185	15	—	AB 4669 E0
155	190	14	AC 4672 E0	—
155	200	20	—	AB 4678 E1
160	190	14	—	AB 4711 E0
160	190	15	AC 4712 E0	AB 4712 E0
160	190	16	AC 4713 E3	AB 4713 A0
160	195	18	AC 4717 E2	—
160	200	14	—	AB 4719 E0
160	200	20	—	AB 4721 E0
160	210	20	AC 4724 E3	AB 4724 E0
165	220	20	—	AB 4753 E0
170	200	16	—	AB 4795 A0
170	210	15	AC 4804 E0	—
170	225	20	AC 4815 E0	AB 4815 E0
175	230	20	—	AB 4855 E0
180	210	15	AC 4897 F0	—
180	210	16	AC 4898 E0	AB 4898 A0
180	215	16	—	AB 4904 E0
180	220	15	—	AB 4908 E1
180	220	20	AC 4911 E1	—
180	225	20	—	AB 4913 E0
180	235	20	—	AB 4915 E2
190	220	14	—	AB 4974 F0
190	220	15	AC 4975 E4	AB 4975 E0
190	225	15	AC 4982 E0	—
190	225	16	—	AB 4983 E0
190	245	22	AC 4993 E0	AB 4993 E0
200	230	14	AC 5052 E0	—
200	230	15	AC 5053 E1	AB 5053 P2
200	230	16	AC 5054 E0	AB 5054 G0
200	230	18	—	AB 5056 E0
200	235	16	—	AB 5060 E6
200	240	16	—	AB 5065 E0
200	240	20	AC 5068 E4	AB 5068 A0
200	242	20	AC 5070 E1	—
200	250	16	AC 5075 E0	—
200	255	22	—	AB 5079 E0



SC Type, SB Type

Material Nitrile (NBR)

● The sectional view on the right shows the typical profile of the seal type.

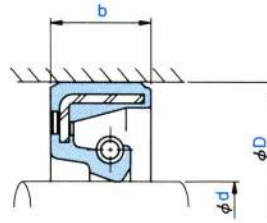

SC type

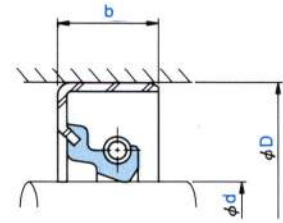

SB type

Dimensions			Part Number	Part Number
Shaft diameter d	Outside diameter D	Width b		
205	260	23	—	AB 5113 E0
210	240	15	AC 5133 E0	AB 5133 E0
210	250	16	—	AB 5138 E0
210	250	18	—	AB 5139 E0
210	250	20	AC 5140 E0	AB 5140 A0
210	265	23	—	AB 5146 E0
210	265	25	AC 5147 E1	—
220	250	15	AC 5204 E6	AB 5204 E0
220	255	16	AC 5207 E0	AB 5207 E0
220	259	22	AC 5210 E0	—
220	260	22	—	AB 5216 A0
220	275	23	AC 5224 E0	AB 5224 E0
230	260	15	AC 5281 E0	—
230	260	20	—	AB 5283 A0
230	285	23	AC 5296 E0	AB 5296 E0
240	270	15	AC 5339 E0	—
240	275	16	AC 5346 E2	—
240	280	19	—	AB 5351 A0
250	280	15	AC 5398 E1	AB 5398 E7
250	310	25	AC 5412 E5	AB 5412 A0
260	300	20	AC 5461 E6	—
260	320	25	—	AB 5471 A0
270	330	25	—	AB 5523 A0
280	316	18	AC 5558 E1	—
280	320	18	—	AB 5560 E0
280	330	24	AC 5568 E0	—
280	340	28	—	AB 5572 A0
290	330	18	—	AB 5586 E0
290	350	25	—	AB 5597 A0
300	345	22	—	AB 5631 E0
300	360	25	—	AB 5640 A0

NOK Standard Oil Seals

SC_{Type}, SB_{Type}

Acrylic rubber (ACM) oil seal



H

- When ordering, please indicate the NOK part number and the relevant dimensions.
- Check the Guide to Allowable Operating Conditions on pages E-6 and E-7 for relevant information on the seal selected before use.

Lip Material	NOK T303
--------------	----------

SC Type, SB Type

Material Acrylic (ACM)

● The sectional view on the right shows the typical profile of the seal type.

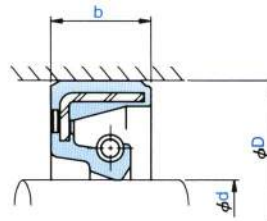

SC type

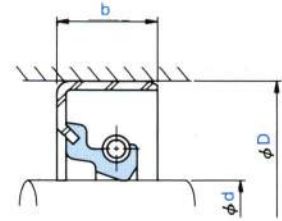

SB type

Dimensions			Part Number	Part Number
Shaft diameter d	Outside diameter D	Width b		
10	22	7	AC 0270 E1	—
10	25	7	AC 0279 A1	—
12	25	7	AC 0382 A1	—
15	30	7	AC 0598 G0	—
16	30	7	AC 0687 F1	—
17	30	8	AC 0745 G0	—
18	30	8	AC 0817 G0	—
20	35	8	AC 1013 A1	—
22	42	10	—	AB 1147 F0
25	40	8	AC 1314 A1	—
25	45	10	—	AB 1337 G0
28	40	8	AC 1538 H0	—
28	48	11	AC 1563 A1	—
30	45	8	AC 1679 A1	AB 1679 F0
30	50	11	AC 1709 A1	—
32	52	11	AC 1904 A1	—
35	50	8	AC 2057 A1	—
35	55	11	AC 2085 A1	—
38	58	11	AC 2240 A1	AB 2240 F0
40	58	8	AC 2369 E0	AB 2369 G0
42	60	9	—	AB 2493 E0
45	61	9	—	AB 2647 F0
45	62	9	AC 2651 A1	—
45	68	12	AC 2668 A1	AB 2668 G0
48	70	12	—	AB 2791 F0
50	72	12	AC 2864 A1	AB 2864 H0
55	78	12	AC 3055 A1	AB 3055 G0
58	80	12	—	AB 3154 F0
60	78	9	—	AB 3204 G0
60	82	12	AC 3222 A1	AB 3222 H0
62	85	12	AC 3297 A1	—
65	88	12	—	AB 3400 E1
65	90	13	—	AB 3409 H0
68	90	12	—	AB 3459 G0
70	92	12	—	AB 3519 F1
70	95	13	AC 3527 A1	—
75	95	10	AC 3609 F0	—
75	100	13	AC 3618 A1	AB 3618 A4
80	100	10	AC 3732 G0	—
80	105	13	AC 3744 A1	AB 3744 A4

NOK Standard Oil Seals

SC_{Type}, SB_{Type}

Silicone rubber (VMQ) oil seal

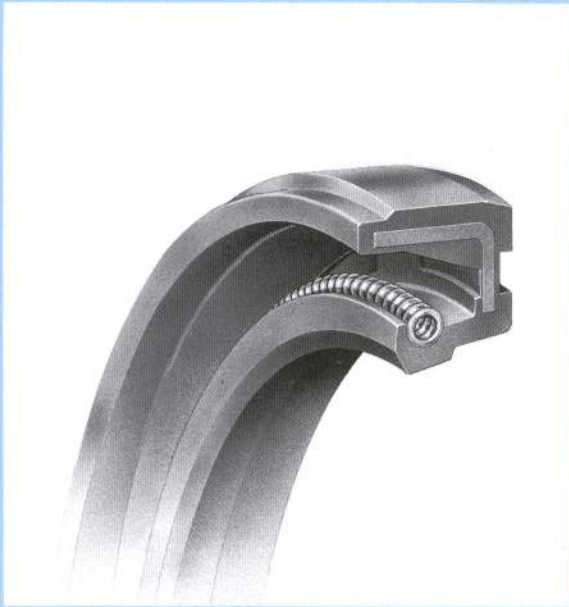

- When ordering, please indicate the NOK part number and the relevant dimensions.
- Check the Guide to Allowable Operating Conditions on pages E-6 and E-7 for relevant information on the seal selected before use.

Lip Material	NOK S728
--------------	----------

SC Type, SB Type

Material Silicone (VMQ)

● The sectional view on the right shows the typical profile of the seal type.

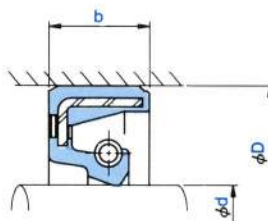

SC type

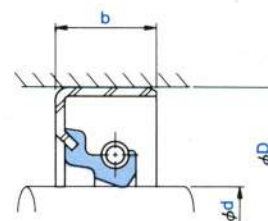

SB type

Dimensions			Part Number	Part Number
Shaft diameter d	Outside diameter D	Width b		
8	22	7	AC 0158 A9	—
10	25	7	AC 0279 A6	—
12	25	7	AC 0382 A6	—
14	28	7	AC 0526 E1	—
15	30	7	AC 0598 A5	—
15	35	7	AC 0610 E2	—
16	30	7	AC 0687 A2	—
17	35	8	AC 0760 A2	—
18	35	8	AC 0829 A4	—
20	35	7	AC 1012 G1	—
20	35	8	AC 1013 A2	—
20	36	7	AC 1017 F0	—
22	38	8	—	AB 1133 F0
25	40	8	AC 1314 A2	AB 1314 H0
25	45	11	AC 1338 A2	AB 1338 G2
26	42	8	AC 1474 A2	—
27	47	11	AC 1518 A2	—
30	45	8	AC 1679 A5	AB 1679 E1
30	50	8	—	AB 1705 E0
30	50	11	AC 1709 A2	—
30	52	12	AC 1724 E1	—
32	52	11	AC 1904 A4	—
35	50	7	—	AB 2056 I0
35	50	8	AC 2057 A7	—
35	55	9	—	AB 2083 E0
35	55	11	—	AB 2085 H0
38	55	8	—	AB 2230 F0
38	58	11	AC 2240 A2	—
40	58	8	AC 2369 A9	—
40	62	11	AC 2388 A2	—
40	62	12	AC 2390 F0	AB 2390 G2
42	65	12	AC 2507 E0	AB 2507 H1
45	61	9	—	AB 2647 E0
45	62	9	AC 2651 A2	AB 2651 H0
45	68	12	—	AB 2668 K3
48	70	12	AC 2791 A2	AB 2791 F1
50	68	9	AC 2847 A2	AB 2847 F2
50	70	10	—	AB 2854 E0
50	72	12	AC 2864 A2	—
55	72	9	AC 3040 A7	AB 3040 F0



SC Type, SB Type

Material Silicone (VMQ)

● The sectional view on the right shows the typical profile of the seal type.

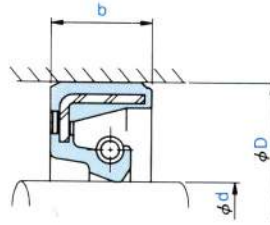

SC type

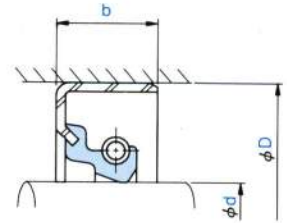

SB type

Dimensions			Part Number	Part Number
Shaft diameter d	Outside diameter D	Width b		
55	78	12	AC 3055 F0	—
58	80	9	—	AB 3152 E0
60	78	9	—	AB 3204 E3
60	80	10	AC 3211 F1	—
60	82	12	AC 3222 A2	AB 3222 I3
60	90	14	—	AB 3244 F1
62	85	12	AC 3297 A4	—
65	88	12	AC 3400 A2	AB 3400 E0
65	90	13	AC 3409 A2	AB 3409 E0
68	95	13	—	AB 3463 F1
70	92	12	AC 3519 A2	AB 3519 F2
70	95	13	—	AB 3527 F2
70	100	14	—	AB 3532 E0
72	100	12	—	AB 3562 E0
75	100	13	AC 3618 A4	AB 3618 A7
80	105	13	AC 3744 A2	AB 3744 F2
85	110	13	AC 3842 A2	—
90	115	13	AC 3932 F1	AB 3932 G8
90	125	15	—	AB 3944 F0
95	120	13	AC 3994 A2	AB 3994 G2
100	125	13	AC 4063 F1	AB 4063 E0
105	135	14	—	AB 4153 F3
110	140	14	—	AB 4212 G0
110	145	15	—	AB 4221 F0
115	145	14	AC 4282 E2	AB 4282 E1
120	150	14	—	AB 4346 A2
125	155	14	—	AB 4399 E0
130	160	14	—	AB 4451 E0
135	165	14	—	AB 4498 F1
140	170	14	—	AB 4542 E1
145	175	14	—	AB 4581 A2
150	180	14	AC 4624 F2	AB 4624 E0
160	190	16	—	AB 4713 H2
180	210	16	—	AB 4898 E2

NOK Standard Oil Seals

SC_{Type}, SB_{Type}

Fluorocarbon rubber (FKM) oil seal



H

- When ordering, please indicate the NOK part number and the relevant dimensions.
- Check the Guide to Allowable Operating Conditions on pages E-6 and E-7 for relevant information on the seal selected before use.

Lip Material	NOK F585
--------------	----------

SC Type, SB Type

Material Fluorocarbon (FKM)

● The sectional view on the right shows the typical profile of the seal type.

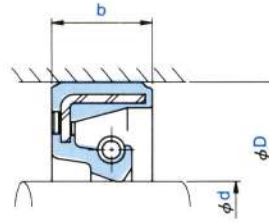

SC type

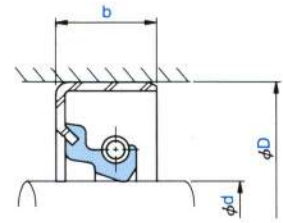

SB type

Dimensions			Part Number	Part Number
Shaft diameter d	Outside diameter D	Width b		
7	20	7	AC 0090 E3	—
8	22	7	AC 0158 F2	AB 0158 A3
10	25	7	—	AB 0279 A3
12	22	7	AC 0371 G1	—
12	25	7	—	AB 0382 A5
12	32	7	AC 0399 E1	—
13	30	9	AC 0484 F2	—
15	30	7	AC 0598 E0	AB 0598 A4
15	35	7	AC 0610 E3	—
16	30	7	—	AB 0687 A4
17	30	7	AC 0743 F0	—
17	30	8	AC 0745 F2	—
17	35	8	—	AB 0760 A3
18	30	8	AC 0817 F1	—
18	35	8	—	AB 0829 A3
19	35	8	AC 0875 F0	AB 0875 A4
20	35	8	AC 1013 E1	AB 1013 A3
20	40	8	AC 1030 F0	—
20	40	11	AC 1033 E4	AB 1033 A3
22	42	10	AC 1147 F0	—
24	40	8	—	AB 1260 A4
25	40	8	AC 1314 F0	AB 1314 A3
25	45	11	AC 1338 G1	AB 1338 A3
28	48	11	—	AB 1563 A3
30	45	8	—	AB 1679 A3
30	45	9	AC 1680 E1	—
30	45	12	AC 1682 F1	—
30	50	11	AC 1709 E3	AB 1709 A3
32	45	8	AC 1880 H1	—
32	52	11	AC 1904 E4	AB 1904 G1
35	50	8	AC 2057 E4	AB 2057 A7
35	52	10	AC 2069 F0	—
35	55	8	AC 2081 G0	—
35	55	11	AC 2085 E2	AB 2085 A3
38	58	11	AC 2240 E2	AB 2240 A3
40	58	8	—	AB 2369 A3
40	60	12	AC 2379 F1	—
40	62	11	—	AB 2388 A3
40	62	12	AC 2390 G6	—
42	65	12	—	AB 2507 A6

SC Type, SB Type

Material Fluorocarbon (FKM)

● The sectional view on the right shows the typical profile of the seal type.

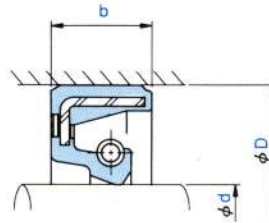

SC type

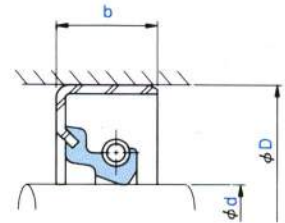

SB type

Dimensions			Part Number	Part Number
Shaft diameter d	Outside diameter D	Width b		
45	62	9	—	AB 2651 A3
45	68	12	AC 2668 E1	AB 2668 A5
48	70	12	AC 2791 E0	AB 2791 A3
50	68	9	AC 2847 F3	AB 2847 A3
50	72	12	AC 2864 G5	AB 2864 A3
52	75	12	—	AB 2967 A3
55	72	9	—	AB 3040 A3
55	78	12	AC 3055 H2	AB 3055 A6
58	80	9	—	AB 3152 F0
58	80	12	AC 3154 A7	AB 3154 A5
60	78	9	AC 3204 F2	—
60	80	10	AC 3211 G1	—
60	82	12	AC 3222 E8	AB 3222 A3
60	90	13	AC 3243 E1	—
62	85	12	—	AB 3297 A3
65	88	12	—	AB 3400 A3
65	90	13	AC 3409 G2	AB 3409 G1
65	95	14	AC 3414 E0	—
68	90	12	—	AB 3459 A3
70	92	12	AC 3519 G6	AB 3519 A3
70	95	13	—	AB 3527 A3
72	100	12	—	AB 3562 F0
75	100	13	AC 3618 F5	AB 3618 A3
80	105	13	AC 3744 I2	AB 3744 A3
85	110	13	AC 3842 F1	AB 3842 A3
90	115	13	AC 3932 E5	AB 3932 A5
95	120	13	AC 3994 A5	AB 3994 A3
100	125	13	AC 4063 H0	AB 4063 E1
105	135	14	AC 4153 E6	AB 4153 A3
110	140	14	AC 4212 F6	AB 4212 A3
115	145	14	—	AB 4282 A3
120	150	14	AC 4346 E0	AB 4346 A3
125	155	14	—	AB 4399 A3
130	160	14	—	AB 4451 A3
135	165	14	AC 4498 F4	AB 4498 A3
140	170	14	—	AB 4542 A3
145	175	14	AC 4581 G1	AB 4581 A3
150	180	14	AC 4624 G1	AB 4624 A3
160	190	16	—	AB 4713 F0
160	200	15	AC 4720 E1	—

NOK Standard Oil Seals

TC_{Type}, TB_{Type}

Nitrile rubber (NBR) oil seal

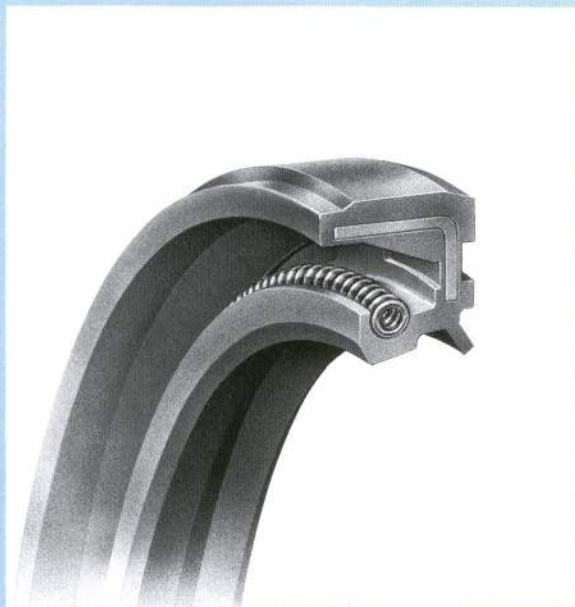

- When ordering, please indicate the NOK part number and the relevant dimensions.
- Check the Guide to Allowable Operating Conditions on pages E-6 and E-7 for relevant information on the seal selected before use.

Lip Material	NOK A727: Shaft diameter class 150 mm or smaller NOK A941: Shaft diameter class 150 mm or larger
--------------	---

TC Type, TB Type

Material Nitrile (NBR)

● The sectional view on the right shows the typical profile of the seal type.

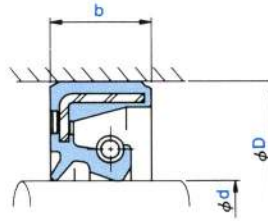

TC type

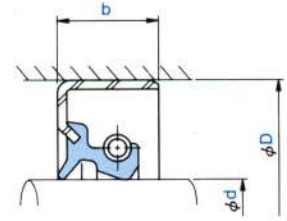

TB type

Dimensions			Part Number	Part Number
Shaft diameter d	Outside diameter D	Width b		
7	20	7	AE 0090 A0	—
8	22	7	AE 0158 A4	AD 0158 E0
8	25	8	AE 0164 E0	—
8	34	8	AE 0169 E0	—
9	22	7	AE 0205 A0	—
9	28	8	AE 0210 E0	—
10	20	7	AE 0260 J0	AD 0260 E1
10	25	7	AE 0279 A6	AD 0279 E0
10	28	8	AE 0285 E0	—
11	25	7	AE 0311 E0	AD 0311 E0
11	30	10	AE 0315 E0	—
12	22	7	AE 0371 E0	AD 0371 E0
12	23	8	AE 0375 E0	—
12	25	7	AE 0382 A0	AD 0382 E0
12	28	7	AE 0387 E0	—
12	30	9	AE 0393 E0	—
12	32	7	AE 0399 E1	—
13	25	7	AE 0473 F0	AD 0473 E0
13	28	7	AE 0478 A0	—
13	30	8	AE 0483 G0	—
14	25	7	AE 0519 E0	—
14	28	7	AE 0526 A0	AD 0526 E0
14	28	11	AE 0529 E0	—
14	32	9	AE 0536 E0	—
15	25	7	AE 0588 K1	AD 0588 G0
15	30	7	AE 0598 A0	AD 0598 G0
15	30	10	AE 0600 E0	—
15	32	9	AE 0604 E0	AD 0604 E0
15	35	7	AE 0610 F0	—
15	35	8	AE 0611 E1	—
16	26	7	AE 0678 F1	AD 0678 F0
16	28	7	AE 0685 G0	AD 0685 F0
16	30	7	AE 0687 A0	AD 0687 H0
16	35	9	AE 0698 E0	—
17	28	6	—	AD 0735 P0
17	30	7	AE 0743 E0	—
17	30	8	AE 0745 E8	AD 0745 E1
17	32	7	AE 0750 E0	—
17	32	8	AE 0751 H6	AD 0751 F0
17	35	7	AE 0759 E0	AD 0759 E0

TC Type, TB Type

Material Nitrile (NBR)

● The sectional view on the right shows the typical profile of the seal type.

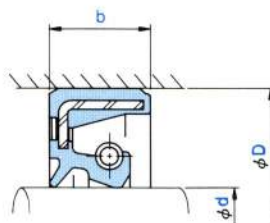

TC type

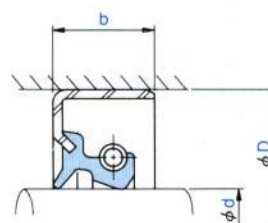

TB type

Dimensions			Part Number	Part Number
Shaft diameter d	Outside diameter D	Width b		
17	35	8	AE 0760 H5	AD 0760 E1
17	35	10	AE 0761 F0	—
17	38	7	AE 0768 E0	AD 0768 E0
17	40	9	AE 0772 E1	—
18	30	8	AE 0817 E0	—
18	32	7	AE 0823 E0	AD 0823 E0
18	35	8	AE 0829 A0	AD 0829 F0
18	35	9	AE 0831 E0	—
18	38	7	AE 0838 E0	—
19	32	8	AE 0870 E0	—
19	35	7	AE 0874 E1	—
19	35	8	AE 0875 A0	AD 0875 E0
19	36	7	AE 0879 E0	—
19	38	7	AE 0880 E0	AD 0880 E0
19	38	10	AE 0881 E0	AD 0881 E0
20	30	7	AE 0984 H0	—
20	32	6	AE 0995 E0	—
20	32	8	AE 0997 E0	AD 0997 I1
20	34	7	AE 1003 E2	—
20	35	7	AE 1012 G0	AD 1012 F2
20	35	8	AE 1013 A4	AD 1013 E0
20	35	10	AE 1015 F0	AD 1015 F0
20	36	7	AE 1017 F0	AD 1017 E0
20	37	7	AE 1020 E1	—
20	37	9	AE 1022 E1	—
20	37	10	AE 6758 E0	—
20	38	7	AE 1024 F0	—
20	40	7	AE 1029 E0	AD 1029 F0
20	40	8	AE 1030 E1	—
20	40	9	AE 1031 E0	—
20	40	10	AE 1032 G0	AD 1032 F0
20	40	11	AE 1033 A0	AD 1033 F0
20	42	8	AE 1037 E0	—
20	44	12	AE 1042 E0	—
20	45	8	AE 1043 E1	—
20	45	12	AE 1045 E0	AD 1045 E0
21	38	8	AE 1089 E0	—
21	40	7	AE 1092 E2	—
22	35	8	AE 1127 E0	AD 1127 E0
22	38	8	AE 1133 E0	AD 1133 F1



TC Type, TB Type

Material Nitrile (NBR)

● The sectional view on the right shows the typical profile of the seal type.

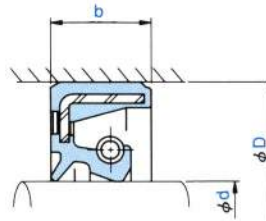

TC type

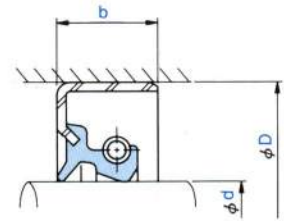

TB type

Dimensions			Part Number	Part Number
Shaft diameter d	Outside diameter D	Width b		
22	40	11	AE 1141 E0	—
22	42	7	AE 1145 E0	AD 1145 E0
22	42	10	AE 1147 E0	AD 1147 F0
22	42	11	AE 1148 A5	AD 1148 F0
23	42	11	AE 1224 A0	AD 1224 E4
24	38	8	AE 1252 E0	AD 1252 E0
24	38	10	AE 1255 E1	—
24	40	8	AE 1260 A0	AD 1260 E0
24	45	7	AE 1265 E3	—
24	45	10	AE 1266 E0	AD 1266 F0
25	35	6	AE 1292 G0	—
25	38	7	AE 1306 K0	AD 1306 H1
25	38	8	AE 1307 E1	AD 1307 E0
25	40	7	AE 1313 E2	AD 1313 E3
25	40	8	AE 1314 A0	AD 1314 F0
25	40	10	AE 1315 F0	—
25	42	8	AE 1322 F2	—
25	42	11	AE 1325 E0	—
25	45	7	AE 1334 E0	—
25	45	8	AE 1335 E0	AD 1335 E0
25	45	10	AE 1337 F0	AD 1337 G0
25	45	11	AE 1338 A0	AD 1338 E2
25	45	12	AE 1339 E0	—
25	46	7	AE 1344 E0	—
25	47	7	AE 1350 E1	—
25	47	8	AE 1351 E2	AD 1351 E1
25	48	7	AE 1356 E0	AD 1356 E0
25	49	12	AE 1358 E0	—
25	50	12	AE 1363 E0	—
25	50	14	—	AD 1364 E0
25	52	10	AE 1377 F0	—
26	38	7	AE 1463 E0	—
26	40	7	AE 1467 E0	AD 1467 E0
26	40	8	—	AD 1468 E0
26	40	9	—	AD 1469 E0
26	42	8	AE 1474 A0	AD 1474 E0
26	48	11	AE 1481 E0	AD 1481 E0
26	52	8	AE 1484 E1	—
27	42	7	AE 1510 E0	—
27	47	11	AE 1518 A0	AD 1518 H0

TC Type, TB Type

Material Nitrile (NBR)

● The sectional view on the right shows the typical profile of the seal type.

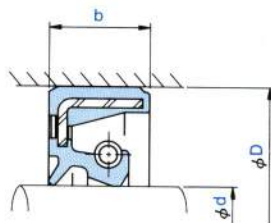

TC type

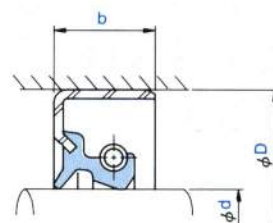

TB type

Dimensions			Part Number	Part Number
Shaft diameter d	Outside diameter D	Width b		
28	40	8	AE 1538 E5	AD 1538 E0
28	42	7	AE 1543 E1	—
28	42	8	AE 1544 F0	—
28	44	8	AE 1545 F0	AD 1545 E0
28	44	11	AE 1546 E0	AD 1546 E0
28	45	8	AE 1550 F4	AD 1550 F0
28	45	11	AE 1553 F0	—
28	47	7	AE 1557 E1	—
28	47	8	AE 1558 F0	—
28	48	8	AE 1562 F1	AD 1562 E0
28	48	11	AE 1563 A0	AD 1563 E0
29	45	9	AE 1630 E0	—
30	42	8	AE 1666 F0	AD 1666 E0
30	44	7	—	AD 1671 G0
30	45	8	AE 1679 A0	AD 1679 G0
30	45	11	AE 1681 E1	AD 1681 E0
30	46	7	AE 1688 E0	—
30	46	9	AE 1689 E1	—
30	46	10	AE 1690 E0	—
30	47	8	AE 1692 E1	—
30	47	10	AE 1693 E1	—
30	48	7	AE 1699 E1	AD 1699 E0
30	48	8	AE 1700 E0	—
30	48	11	AE 1702 E0	—
30	50	7	AE 1704 E0	—
30	50	8	AE 1705 G0	AD 1705 E0
30	50	11	AE 1709 A0	AD 1709 E0
30	50	13	AE 1712 E0	—
30	52	8	AE 1720 E0	AD 1720 E0
30	52	11	AE 1723 F0	AD 1723 E0
30	52	12	AE 1724 E0	—
30	55	12	AE 1736 E1	—
30	55	14	AE 1738 E0	—
31	45	9	AE 1794 E0	—
32	45	8	—	AD 1880 E0
32	48	8	AE 1894 G0	AD 1894 E0
32	52	8	AE 1902 E0	AD 1902 E1
32	52	11	AE 1904 A0	AD 1904 F0
32	54	10	AE 1910 E0	—
33	44	8	—	AD 1929 F1



TC Type, TB Type

Material Nitrile (NBR)

● The sectional view on the right shows the typical profile of the seal type.

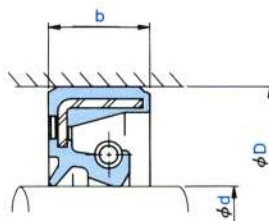

TC type

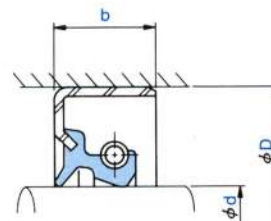

TB type

Dimensions			Part Number	Part Number
Shaft diameter d	Outside diameter D	Width b		
33	50	11	AE 1935 E1	—
34	52	11	AE 1975 E0	—
34	54	11	AE 1978 A0	AD 1978 E0
35	48	8	AE 2048 K0	AD 2048 F0
35	50	7	AE 2056 E0	—
35	50	8	AE 2057 A0	AD 2057 G2
35	50	12	AE 2061 E0	—
35	52	7	AE 2066 E0	AD 2066 E0
35	52	8	AE 2067 E1	—
35	52	9	AE 2068 E0	—
35	52	11	AE 2071 F0	AD 2071 E1
35	52	12	AE 2072 E0	AD 2072 E0
35	55	8	AE 2081 E0	AD 2081 F0
35	55	9	AE 2083 E1	AD 2083 E0
35	55	10	AE 2084 E0	—
35	55	11	AE 2085 A0	AD 2085 G0
35	55	12	AE 2086 E1	—
35	60	12	AE 2107 E1	AD 2107 E0
35	60	14	AE 2108 E0	AD 2108 F0
35	62	12	AE 2121 F1	—
36	58	12	AE 2170 E0	—
37	53	7	AE 2196 E0	—
38	50	8	AE 2218 E0	—
38	55	8	AE 2230 E0	AD 2230 I0
38	55	9	AE 2231 F0	AD 2231 E0
38	58	7	AE 2238 E0	—
38	58	8	AE 2239 E0	AD 2239 E0
38	58	11	AE 2240 A0	AD 2240 I0
38	58	13	AE 2242 E0	—
38	60	11	AE 2245 E0	—
38	62	9	AE 2249 E0	—
38	62	11	AE 2250 E0	—
40	52	8	AE 2343 E0	AD 2343 E0
40	55	8	AE 2359 H0	AD 2359 G0
40	55	9	AE 2361 E0	—
40	56	10	AE 2366 E0	—
40	58	8	AE 2369 A0	AD 2369 F0
40	58	12	AE 2372 E0	—
40	60	12	AE 2379 E0	AD 2379 E0
40	62	8	AE 2386 H1	AD 2386 E0

TC Type, TB Type

Material Nitrile (NBR)

● The sectional view on the right shows the typical profile of the seal type.

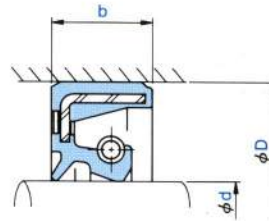

TC type

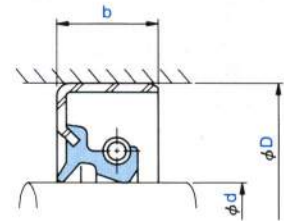

TB type

Dimensions			Part Number	Part Number
Shaft diameter d	Outside diameter D	Width b		
40	62	11	AE 2388 A0	AD 2388 E0
40	62	12	AE 2390 K0	AD 2390 I0
40	63	7	AE 2396 F0	—
40	65	10	AE 2402 E0	—
40	65	12	AE 2403 F0	AD 2403 E0
40	65	14	AE 2405 E1	AD 2405 E0
40	68	11	—	AD 7424 E0
42	55	9	AE 2483 E0	—
42	60	9	AE 2493 E0	AD 2493 E0
42	65	9	AE 2504 F0	AD 2504 E0
42	65	12	AE 2507 A0	AD 2507 I0
44	60	9	AE 2557 E2	—
44	62	10	AE 2560 E0	—
45	60	9	AE 2643 E1	AD 2643 G0
45	62	9	AE 2651 A0	AD 2651 G0
45	62	12	—	AD 2653 E0
45	68	9	A E2666 E0	AD 2666 G1
45	68	12	AE 2668 A0	AD 2668 G0
45	68	14	AE 2670 E0	—
45	70	12	AE 2676 E0	AD 2676 E0
45	70	14	AE 2677 E0	AD 2677 E0
45	72	12	AE 2685 H0	AD 2685 E0
46	64	11	AE 2716 E0	—
48	62	9	AE 2775 E0	—
48	65	9	AE 2780 F0	AD 2780 G0
48	70	9	AE 2788 H1	AD 2788 E0
48	70	12	AE 2791 A0	AD 2791 E0
48	70	14	AE 2793 E0	—
49	70	11	AE 2808 E0	—
50	65	9	—	AD 2838 F0
50	68	9	AE 2847 A0	AD 2847 F0
50	68	10	AE 2848 G0	—
50	70	10	AE 2854 E0	AD 2854 F0
50	70	11	AE 2856 E0	—
50	70	12	AE 2857 E0	—
50	72	9	AE 2861 E1	AD 2861 E2
50	72	10	AE 2862 E1	AD 2862 E0
50	72	12	AE 2864 A0	AD 2864 G0
50	72	14	—	AD 2867 F0
50	80	12	AE 2887 E0	—

TC Type, TB Type

Material Nitrile (NBR)

● The sectional view on the right shows the typical profile of the seal type.

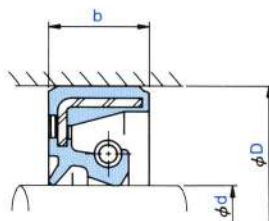

TC type

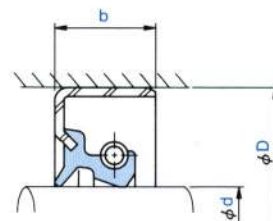

TB type

Dimensions			Part Number	Part Number
Shaft diameter d	Outside diameter D	Width b		
50	80	14	AE 2888 E0	AD 2888 F0
52	70	9	AE 2959 H1	AD 2959 F0
52	75	9	AE 2965 F1	—
52	75	12	AE 2967 A0	AD 2967 E0
52	75	14	AE 2969 E0	—
52	78	12	AE 2972 E0	—
54	70	9	AE 3010 E0	—
55	72	9	AE 3040 A0	AD 3040 F0
55	72	12	AE 3042 E2	AD 3042 E0
55	75	9	AE 3045 E0	—
55	78	9	—	AD 3053 E0
55	78	12	AE 3055 A0	AD 3055 H0
55	78	14	AE 3056 E0	—
55	79	13	AE 3059 E0	—
55	80	10	AE 3061 E0	—
55	80	12	AE 3062 E1	AD 3062 E0
55	85	14	AE 3072 F0	AD 3072 E0
56	72	9	AE 3092 E2	AD 3092 E0
56	78	9	AE 3093 E0	—
56	78	12	AE 3094 E0	AD 3094 E0
58	75	9	AE 3148 F1	—
58	80	9	AE 3152 E0	AD 3152 E0
58	80	12	AE 3154 A6	AD 3154 F0
58	90	11	AE 3159 E0	—
60	75	9	AE 3193 F0	AD 3193 F0
60	78	9	AE 3204 E0	AD 3204 F0
60	80	12	AE 3213 E5	AD 3213 F0
60	80	13	AE 3215 E0	—
60	82	9	AE 3220 E0	AD 3220 E0
60	82	12	AE 3222 A0	AD 3222 I0
60	82	14	AE 3224 E0	AD 3224 E0
60	85	12	AE 3234 F2	—
60	90	11	AE 3241 E1	—
60	90	13	AE 3243 E0	—
60	90	14	AE 3244 E0	AD 3244 E0
62	80	9	AE 3290 E3	AD 3290 E0
62	85	9	AE 3295 E0	AD 3295 E0
62	85	12	AE 3297 A0	AD 3297 F4
63	80	9	AE 3316 F0	AD 3316 E0
63	85	12	AE 3321 E0	AD 3321 E2

TC Type, TB Type

Material Nitrile (NBR)

● The sectional view on the right shows the typical profile of the seal type.

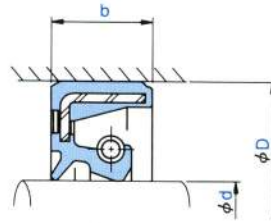

TC type

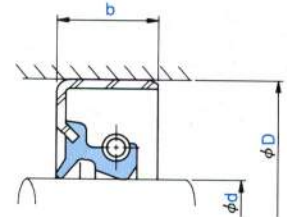

TB type

Dimensions			Part Number	Part Number
Shaft diameter d	Outside diameter D	Width b		
65	88	12	AE 3400 A0	AD 3400 I0
65	88	14	AE 3402 E0	AD 3402 E0
65	90	13	AE 3409 A0	AD 3409 J0
65	95	14	AE 3414 F1	—
65	95	16	—	AD 3415 E0
68	90	12	AE 3459 A5	AD 3459 H0
68	95	13	AE 3463 F0	AD 3463 E9
70	88	12	AE 3505 F3	AD 3505 H0
70	90	12	AE 3513 E0	—
70	92	12	AE 3519 A0	AD 3519 K0
70	92	14	AE 3521 E0	AD 3521 G0
70	95	13	AE 3527 E0	AD 3527 H0
70	100	13	AE 8520 E2	—
70	100	14	—	AD 3532 E0
71	95	13	AE 3549 E0	AD 3549 E0
72	94	10	—	BD 1423 E1
75	95	13	AE 3611 E0	—
75	100	13	AE 3618 A0	AD 3618 I0
75	105	15	—	AD 3631 F0
75	110	13	—	AD 3636 E0
78	100	13	—	AD 3694 E0
80	100	12	AE 3733 E0	—
80	100	13	AE 3734 E0	—
80	105	13	AE 3744 A0	AD 3744 J0
80	105	15	AE 3746 F0	AD 3746 E0
80	115	15	AE 3761 E0	AD 3761 E1
85	110	13	AE 3842 A0	AD 3842 I0
85	110	15	AE 3844 E0	AD 3844 F0
85	115	15	AE 3852 E0	AD 3852 E0
85	120	15	AE 3855 E0	AD 3855 E0
90	110	13	—	AD 3921 E0
90	115	13	AE 3932 A9	AD 3932 J0
90	115	15	AE 3934 E0	—
90	120	13	AE 3938 E0	—
90	120	15	AE 3939 E0	—
90	125	15	AE 3944 F0	AD 3944 E0
90	125	17	AE 3945 E0	AD 3945 E0
90	135	15	AE 3951 E0	—
95	115	13	AE 3984 E0	—
95	120	13	AE 3994 A0	AD 3994 G0



TC Type, TB Type

Material Nitrile (NBR)

● The sectional view on the right shows the typical profile of the seal type.

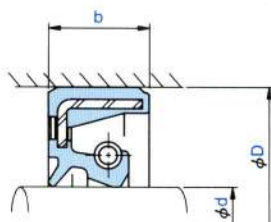

TC type

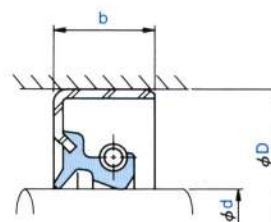

TB type

Dimensions			Part Number	Part Number
Shaft diameter <i>d</i>	Outside diameter <i>D</i>	Width <i>b</i>		
95	120	15	AE 3995 E0	—
95	130	15	AE 4007 E0	AD 4007 E3
95	130	17	—	AD 4008 E0
100	114	12	—	AD 7700 E0
100	125	13	AE 4063 F0	AD 4063 A0
100	125	15	AE 4065 E0	AD 4065 F0
100	130	13	—	AD 4073 E1
100	135	15	AE 4079 E0	AD 4079 E0
100	135	17	—	AD 4081 E0
105	135	14	AE 4153 E0	AD 4153 A0
105	135	16	—	AD 4154 E0
105	140	15	AE 4161 E0	—
110	140	14	AE 4212 H7	AD 4212 A0
110	140	16	—	AD 4214 E0
110	145	15	AE 4221 E0	AD 4221 E0
110	145	17	—	AD 4222 E0
112	145	14	AE 4237 E0	AD 4237 E0
115	140	15	AE 4279 E0	—
115	145	14	AE 4282 E0	AD 4282 A0
115	145	16	—	AD 4284 E0
115	150	16	—	AD 4292 E0
120	150	14	AE 4346 H0	AD 4346 A0
120	150	16	—	AD 4349 F0
120	155	16	AE 4355 E0	AD 4355 E0
120	155	18	—	AD 4356 E0
125	155	14	AE 4399 F0	AD 4399 A0
125	155	16	AE 4400 F0	AD 4400 F0
125	160	16	—	AD 4404 E0
125	160	18	—	AD 4405 E0
130	160	14	AE 4451 F0	AD 4451 A0
130	160	16	—	AD 4453 E0
135	160	14	—	AD 4494 E0
135	165	14	AE 4498 E2	AD 4498 A0
135	175	16	—	AD 4506 E0
140	160	14	AE 4535 G0	—
140	170	14	AE 4542 E0	AD 4542 A0
140	180	16	—	AD 4555 E0
140	185	16	AE 4558 E0	—
145	175	14	AE 4581 E0	AD 4581 A0
145	175	16	—	AD 4582 E0
145	176	14	—	AD 4584 E0

TC Type, TB Type

Material Nitrile (NBR)

● The sectional view on the right shows the typical profile of the seal type.

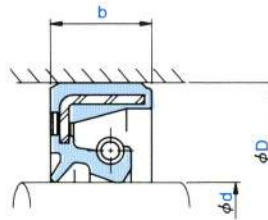

TC type

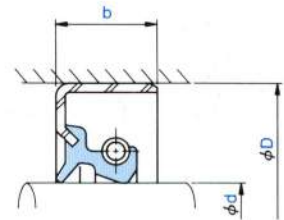

TB type

Shaft diameter d	Dimensions		Part Number	Part Number
	Outside diameter D	Width b		
145	190	16	AE 4588 E0	—
150	180	14	AE 4624 F6	AD 4624 A0
150	180	16	AE 4626 F0	AD 4626 E0
155	180	15	AE 4666 E0	—
155	200	20	AE 4678 E0	AD 4678 F0
160	190	15	AE 4712 E1	—
160	190	16	—	AD 4713 A4
160	196	20	—	AD 4718 E0
170	200	16	AE 4795 E0	AD 4795 A0
170	205	16	AE 4800 E0	—
170	225	20	—	AD 4815 F1
180	210	16	AE 4898 E5	AD 4898 A9
180	215	18	—	AD 4905 E0
185	210	15	AE 4943 E1	—
190	225	16	AE 4983 P2	AD 4983 A9
200	230	15	AE 5053 E2	—
200	235	18	—	AD 5061 X4
200	240	17	—	AD 5066 X0
200	240	20	AE 5068 E2	AD 5068 A8
210	250	16	—	AD 5138 E0
210	250	20	—	AD 5140 A5
220	250	16	AE 5205 E1	—
220	255	18	AE 5208 G3	—
220	260	22	—	AD 5216 A9
220	275	23	AE 5224 E0	—
220	275	26	—	AD 5225 E0
230	260	20	—	AD 5283 A0
230	270	16	AE 5289 E0	—
230	270	20	AE 5290 E0	—
240	270	20	AE 5341 E0	—
240	275	16	AE 5346 E0	—
240	275	18	—	AD 5347 X3
240	280	19	—	AD 5351 A6
250	285	18	—	AD 5404 E0
250	310	25	—	AD 5412 A0
260	320	25	—	AD 5471 A0
270	330	25	—	AD 5523 A0
280	320	22	—	AD 5562 E3
280	340	28	—	AD 5572 A0
290	350	25	—	AD 5597 A0
300	360	25	—	AD 5640 A6

NOK Standard Oil Seals

TC_{Type}, TB_{Type}

Acrylic rubber (ACM) oil seal



- When ordering, please indicate the NOK part number and the relevant dimensions.
- Check the Guide to Allowable Operating Conditions on pages E-6 and E-7 for relevant information on the seal selected before use.

Lip Material	NOK T303
--------------	----------

TC Type, TB Type

Material Acrylic (ACM)

● The sectional view on the right shows the typical profile of the seal type.

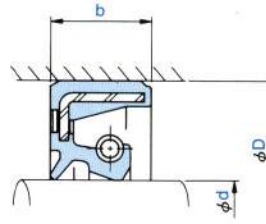

TC type

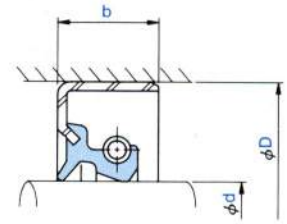

TB type

Dimensions			Part Number	Part Number
Shaft diameter d	Outside diameter D	Width b		
9	22	7	AE 0205 E0	—
12	22	7	AE 0371 L0	—
15	30	7	AE 0598 A1	—
16	30	7	AE 0687 A1	—
18	35	8	—	AD 0829 E0
20	35	7	AE 1012 J0	AD 1012 G0
20	35	8	AE 1013 E0	—
22	38	8	AE 1133 F0	—
22	40	9	AE 1139 E0	—
22	42	10	—	AD 1147 G0
24	40	8	AE 1260 A1	—
25	40	8	AE 1314 A1	AD 1314 E0
25	45	10	—	AD 1337 H0
26	42	8	AE 1474 A1	—
28	45	8	AE 1550 E0	—
28	48	11	—	AD 1563 F0
30	45	8	AE 1679 A1	AD 1679 F0
30	50	8	AE 1705 F0	—
30	50	11	—	AD 1709 F0
32	50	10	AE 1896 E0	—
32	52	8	AE 1902 G0	—
32	52	11	AE 1904 A1	—
35	50	8	AE 2057 H0	AD 2057 F0
35	55	11	AE 2085 A1	AD 2085 F0
38	55	8	AE 2230 H0	—
38	58	11	AE 2240 A1	—
40	58	8	AE 2369 A1	—
40	62	11	AE 2388 A1	AD 2388 P0
40	64	12	AE 2398 E0	—
42	60	9	AE 2493 F0	—
42	65	12	AE 2507 A1	—
45	62	9	AE 2651 A1	AD 2651 F0
45	68	12	AE 2668 A1	AD 2668 I0
48	70	12	AE 2791 A1	—
50	68	9	AE 2847 A7	—
50	72	12	AE 2864 A1	AD 2864 H0
52	75	12	AE 2967 A1	—
55	72	9	AE 3040 A1	—
55	78	12	AE 3055 A1	AD 3055 I0
55	80	12	—	AD 3062 F0



TC Type, TB Type

Material Acrylic (ACM)

● The sectional view on the right shows the typical profile of the seal type.

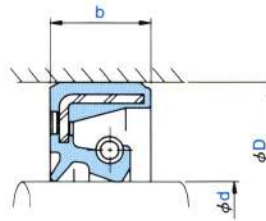

TC type

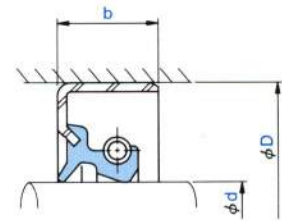

TB type

Dimensions			Part Number	Part Number
Shaft diameter d	Outside diameter D	Width b		
58	80	12	AE 3154 A7	—
60	82	12	AE 3222 A1	AD 3222 S0
60	85	12	AE 3234 E0	—
62	85	12	AE 3297 A1	AD 3297 E0
65	88	12	AE 3400 A1	AD 3400 K0
65	90	13	AE 3409 A1	AD 3409 H0
68	90	12	AE 3459 A1	AD 3459 E0
70	92	12	AE 3519 A1	AD 3519 G0
70	95	13	AE 3527 A1	AD 3527 G1
75	100	13	AE 3618 A1	AD 3618 J0
80	100	13	AE 3734 F0	—
80	105	13	AE 3744 A1	AD 3744 H0
85	110	13	AE 3842 A1	AD 3842 H1
90	115	13	AE 3932 A1	AD 3932 I 1
90	125	17	—	AD 3945 F0
95	120	13	AE 3994 A1	AD 3994 J0
100	125	13	AE 4063 G0	AD 4063 A1
105	135	14	—	AD 4153 A1
110	140	14	AE 4212 F1	AD 4212 A1
115	145	14	—	AD 4282 G0
120	150	14	—	AD 4346 A1
125	155	14	—	AD 4399 A5
130	160	14	—	AD 4451 A1
135	165	14	—	AD 4498 A1
140	170	14	—	AD 4542 A1
145	175	14	—	AD 4581 A1
150	180	14	—	AD 4624 A1
170	200	16	—	AD 4795 E0
170	225	16	—	AD 4814 X0
180	210	16	—	AD 4898 E1
200	235	18	—	AD 5061 X0
210	265	25	—	AD 5147 E2
240	275	18	—	AD 5347 X0

NOK Standard Oil Seals

TC_{Type}, TB_{Type}

Silicone rubber (VMQ) oil seal



- When ordering, please indicate the NOK part number and the relevant dimensions.
- Check the Guide to Allowable Operating Conditions on pages E-6 and E-7 for relevant information on the seal selected before use.

Lip Material	NOK S728
--------------	----------

TC Type, TB Type

Material Silicone (VMQ)

● The sectional view on the right shows the typical profile of the seal type.

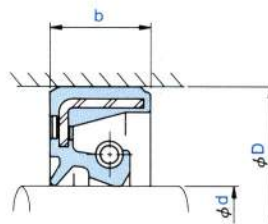

TC type

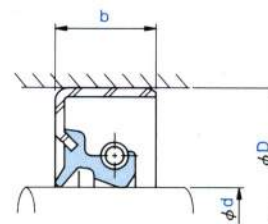

TB type

Dimensions			Part Number	Part Number
Shaft diameter d	Outside diameter D	Width b		
8	22	7	AE 0158 A2	—
10	25	7	AE 0279 A2	—
12	25	7	AE 0382 A2	—
16	30	7	AE 0687 A7	AD 0687 F1
17	32	8	—	AD 0751 E0
17	35	8	AE 0760 A2	—
18	35	8	AE 0829 A2	—
20	35	8	AE 1013 A2	—
20	36	7	AE 1017 G1	—
22	42	11	AE 1148 A2	—
25	40	8	AE 1314 A8	—
25	45	11	AE 1338 A2	—
28	48	11	AE 1563 A2	—
30	45	8	AE 1679 A4	—
30	50	11	AE 1709 A2	—
32	52	11	AE 1904 A7	—
35	50	8	AE 2057 F1	—
35	55	11	AE 2085 Q2	AD 2085 N1
38	58	11	AE 2240 A7	—
40	58	8	AE 2369 A9	—
40	62	11	AE 2388 A6	AD 2388 J1
42	65	12	AE 2507 A2	AD 2507 K1
45	62	9	AE 2651 A8	—
45	68	12	AE 2668 H0	—
48	70	12	AE 2791 A2	—
50	72	12	AE 2864 A9	—
52	70	9	AE 2959 E0	—
52	75	12	AE 2967 A2	—
55	72	9	AE 3040 A7	—
55	78	12	AE 3055 A9	AD 3055 J2
57	77	12	AE 3106 E2	—
60	82	12	AE 3222 A2	—
65	88	12	AE 3400 A7	AD 3400 J2
65	90	13	AE 3409 A6	AD 3409 G1
70	88	12	—	AD 3505 J1
70	92	12	AE 3519 A7	—
70	95	13	AE 3527 A9	AD 3527 G4
75	100	13	AE 3618 A2	AD 3618 G2
80	100	12	AE 3733 G1	—
80	105	13	AE 3744 A7	AD 3744 F3

NOK Standard Oil Seals

TC_{Type}, TB_{Type}

Fluorocarbon rubber (FKM) oil seal



- When ordering, please indicate the NOK part number and the relevant dimensions.
- Check the Guide to Allowable Operating Conditions on pages E-6 and E-7 for relevant information on the seal selected before use.

Lip Material	NOK F585
--------------	----------

TC Type, TB Type

Material Fluorocarbon (FKM)

● The sectional view on the right shows the typical profile of the seal type.

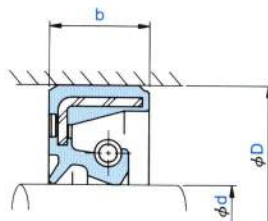

TC type

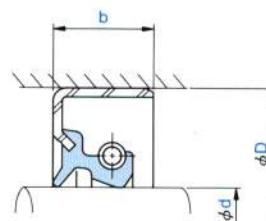

TB type

Dimensions			Part Number	Part Number
Shaft diameter d	Outside diameter D	Width b		
8	22	7	AE 0158 F2	AD 0158 A3
10	25	7	—	AD 0279 A3
12	25	7	AE 0382 K1	AD 0382 A3
14	28	7	AE 0526 F0	AD 0526 A4
15	30	7	—	AD 0598 A3
16	30	7	—	AD 0687 A3
17	35	8	AE 0760 F0	AD 0760 A3
19	35	8	—	AD 0875 A3
20	35	8	AE 1013 F2	AD 1013 A3
20	40	11	—	AD 1033 A3
22	42	11	—	AD 1148 A4
24	40	8	—	AD 1260 A3
25	40	8	AE 1314 J1	AD 1314 A3
25	45	11	AE 1338 G2	AD 1338 A3
28	48	11	—	AD 1563 A6
30	45	8	—	AD 1679 A3
30	50	11	AE 1709 J2	AD 1709 A3
32	52	11	—	AD 1904 A3
35	50	8	—	AD 2057 A5
35	55	11	AE 2085 K4	AD 2085 A3
38	58	11	—	AD 2240 A3
40	55	8	—	AD 2359 H1
40	58	8	—	AD 2369 A5
40	62	11	—	AD 2388 F3
42	65	12	—	AD 2507 A3
45	62	9	AE 2651 F4	AD 2651 A3
45	68	12	—	AD 2668 A4
48	70	12	—	AD 2791 A3
50	68	9	—	AD 2847 A6
50	72	12	AE 2864 J1	AD 2864 A3
52	75	12	—	AD 2967 A3
55	72	9	—	AD 3040 A6
55	78	12	AE 3055 E2	AD 3055 A3
58	80	12	—	AD 3154 A3
60	78	9	AE 3204 G2	—
60	82	12	AE 3222 G0	AD 3222 A3
65	88	12	AE 3400 F1	AD 3400 A3
65	90	13	AE 3409 F4	AD 3409 A5
68	95	13	AE 3463 E0	—
70	88	12	AE 3505 G3	—



TC Type, TB Type

Material Fluorocarbon (FKM)

● The sectional view on the right shows the typical profile of the seal type.

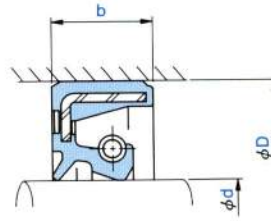

TC type

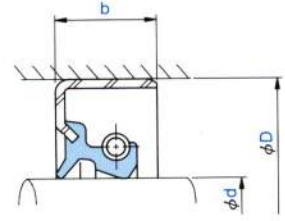

TB type

Dimensions			Part Number	Part Number
Shaft diameter d	Outside diameter D	Width b		
70	92	12	AE 3519 M3	AD 3519 A3
70	95	13	—	AD 3527 A3
75	100	13	AE 3618 F3	AD 3618 A5
80	105	13	—	AD 3744 A3
85	110	13	—	AD 3842 A3
90	115	13	AE 3932 A6	AD 3932 H0
95	120	13	—	AD 3994 A3
100	125	13	AE 4063 I0	AD 4063 A4
100	135	15	AE 4079 F1	—
105	135	14	—	AD 4153 A5
110	140	14	—	AD 4212 A3
115	145	14	—	AD 4282 A3
120	150	14	—	AD 4346 A9
125	155	14	—	AD 4399 E1
130	160	14	—	AD 4451 A3
135	165	14	—	AD 4498 A6
140	170	14	—	AD 4542 A3
145	175	14	—	AD 4581 F0
150	180	14	—	AD 4624 A3
160	190	16	—	AD 4713 A9
170	200	16	—	AD 4795 A3
180	210	16	—	AD 4898 A3
190	225	16	—	AD 4983 A4
200	240	20	—	AD 5068 A3
210	250	20	—	AD 5140 A3
220	260	22	—	AD 5216 A5
230	260	20	—	AD 5283 E0
240	280	19	—	AD 5351 A3
250	310	25	—	AD 5412 A3
260	320	25	—	AD 5471 A3
280	340	28	—	AD 5572 A3
290	350	25	—	AD 5597 A3
300	360	25	—	AD 5640 A7

NOK Standard Oil Seals

TCK_{Type} (new fabric seal)

Nitrile rubber (NBR) +
New fabric (FH) oil seal



H

- When ordering, please indicate the NOK part number and the relevant dimensions.
- Check the Guide to Allowable Operating Conditions on pages E-6 and E-7 for relevant information on the seal selected before use.

Lip Material	NOK A727 + NOK 31FH
--------------	---------------------

NOK Standard Oil Seals

VC_{Type}, VB_{Type}

Nitrile rubber (NBR) oil seals

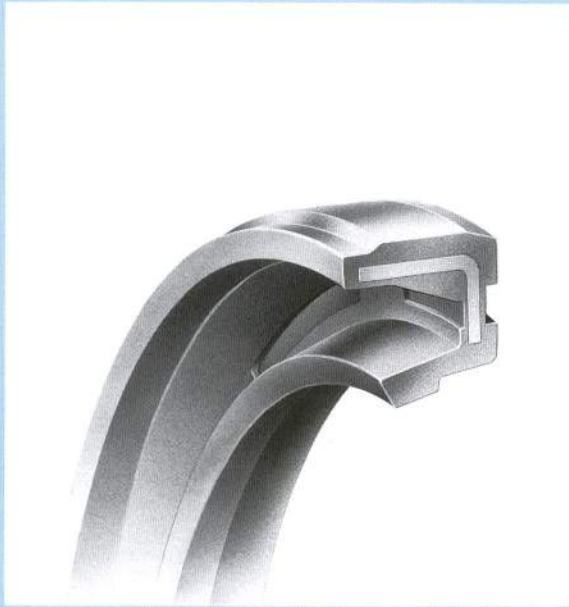

H

- When ordering, please indicate the NOK part number and the relevant dimensions.
- Check the Guide to Allowable Operating Conditions on pages E-6 and E-7 for relevant information on the seal selected before use.

Lip Material	NOK A727: Shaft diameter class 150 mm or smaller NOK A941: Shaft diameter class 150 mm or larger
--------------	---

VC Type, VB Type

Material Nitrile (NBR)

● The sectional view on the right shows the typical profile of the seal type.

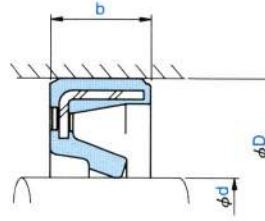

VC type

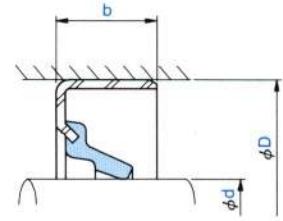

VB type

Dimensions			Part Number	Part Number
Shaft diameter d	Outside diameter D	Width b		
7	16	6	—	AF 0082 E2
7	20	5	AG 0089 A0	AF 0089 E3
8	14	4	AG 0123 E2	AF 0123 F2
8	18	4	AG 0141 E2	—
8	22	5	AG 0156 A0	—
9	22	5	AG 0204 A0	—
10	20	4	AG 0256 E0	AF 0256 E0
10	25	5	AG 0276 A0	AF 0276 E0
12	22	4	AG 0369 E0	AF 0369 E2
12	25	5	AG 0380 A0	AF 0380 E0
12	30	6	AG 0391 E0	AF 0391 E0
12	32	5	AG 0397 E0	—
13	28	5	AG 0477 A0	—
14	24	4	—	AF 0511 F0
14	24	6	AG 0514 E0	AF 0514 E0
14	28	5	AG 0524 A0	AF 0524 E0
14	34	6	AG 0538 E0	—
15	25	4	AG 0585 E0	AF 0585 E0
15	30	4	AG 0595 F0	AF 0595 E0
15	30	5	AG 0596 A0	AF 0596 E0
15	32	6	AG 0602 E0	AF 0602 E0
15	35	6	AG 0608 E0	AF 0608 E0
16	24	4	AG 0668 E0	AF 0668 E0
16	28	4	—	AF 0682 E2
16	30	5	AG 0686 A4	—
17	30	5	—	AF 0741 F1
17	30	7	AG 0743 E0	—
17	32	6	AG 0749 E0	AF 0749 E0
17	35	5	AG 0757 A0	—
18	30	5	—	AF 0814 E0
18	35	6	AG 0827 A0	—
18	38	7	AG 0838 E0	—
19	35	6	AG 0873 A0	AF 0873 E0
19	40	6	—	AF 0882 F0
20	26	6	—	AF 0964 F1
20	32	5	AG 0994 E1	AF 0994 G0
20	34	5	AG 1001 E0	—
20	35	6	AG 1010 A0	AF 1010 F0
20	40	5	AG 1027 A0	AF 1027 E0
20	40	7	AG 1029 E0	—

VC Type, VB Type

Material Nitrile (NBR)

● The sectional view on the right shows the typical profile of the seal type.

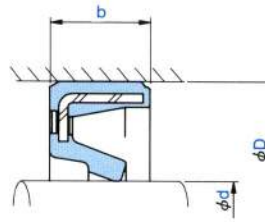

VC type

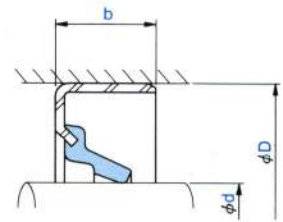

VB type

Dimensions			Part Number	Part Number
Shaft diameter d	Outside diameter D	Width b		
20	42	6	AG 1035 E0	—
20	47	6	—	AF 1047 E0
21	40	7	AG 1092 E0	—
22	32	5	—	AF 1113 E2
22	34	5	AG 1119 E0	—
22	35	5	AG 1124 F0	AF 1124 E0
22	38	6	AG 1132 E0	AF 1132 E0
22	42	5	AG 1144 A0	AF 1144 E0
22	47	7	AG 1161 E0	—
23	32	7	AG 1213 E8	—
23	42	6	AG 1222 A5	—
24	38	5	AG 1250 E0	AF 1250 E0
24	40	6	AG 1258 A0	AF 1258 G0
24	47	5	AG 1268 E0	—
25	35	5	AG 1291 E0	AF 1291 E0
25	38	5	AG 1303 E0	AF 1303 F2
25	40	5	AG 1311 A0	AF 1311 G0
25	40	6	AG 1312 A0	AF 1312 E0
25	41	6	AG 1317 E0	—
25	42	5	AG 1321 E0	—
25	45	5	AG 1333 E0	AF 1333 E0
25	45	7	AG 1334 E0	AF 1334 E0
25	47	5	AG 1347 E0	AF 1347 E0
25	47	6	AG 1348 E1	AF 1348 E0
25	50	5	AG 1359 E1	AF 1359 E0
26	40	5	AG 1466 E0	—
26	42	6	AG 1473 A0	—
26	48	6	AG 1479 E0	AF 1479 E0
27	42	7	AG 1510 E0	—
27	47	8	AG 1517 A0	AF 1517 E0
28	40	5	AG 1535 E0	AF 1535 G0
28	45	6	AG 1548 E0	AF 1548 E0
28	47	5	AG 1556 E0	AF 1556 E0
28	48	5	—	AF 1560 E0
28	48	6	AG 6759 A0	—
28	50	6	AG 1568 E0	AF 1568 F0
30	40	5	AG 1654 E0	AF 1654 E0
30	42	5	AG 1663 F0	AF 1663 E0
30	45	6	AG 1676 A0	AF 1676 E0
30	46	5	AG 1686 E0	AF 1686 E0
30	48	6	AG 1698 E0	—

VC Type, VB Type

Material Nitrile (NBR)

● The sectional view on the right shows the typical profile of the seal type.

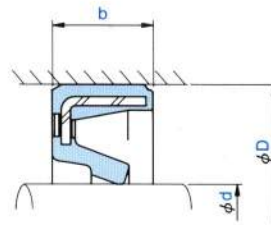

VC type

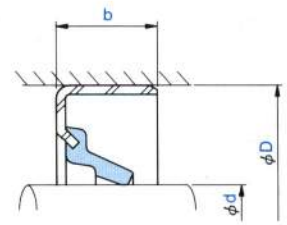

VB type

Dimensions			Part Number	Part Number
Shaft diameter d	Outside diameter D	Width b		
30	50	5	AG 1703 A0	AF 1703 E0
30	50	8	AG 1705 E0	AF 1705 E0
30	52	5	AG 1717 E0	AF 1717 E0
30	55	5	AG 1731 E0	AF 1731 E0
30	56	5	AG 1741 E0	AF 1741 E1
32	45	5	AG 1876 E0	AF 1876 E0
32	48	6	AG 1892 E0	—
32	52	5	AG 1899 A0	AF 1899 E0
34	54	8	AG 6760 A0	—
35	45	5	—	AF 2033 E0
35	47	5	AG 2039 E0	AF 2039 E0
35	48	5	AG 2044 E1	—
35	50	5	AG 2053 E0	AF 2053 E0
35	50	6	AG 2055 A0	AF 2055 E0
35	52	5	AG 2064 E0	AF 2064 E0
35	55	5	AG 2079 A0	AF 2079 F0
35	55	8	AG 2081 E0	AF 2081 E0
35	60	5	AG 2102 E0	AF 2102 E0
35	62	6	AG 2115 E0	—
38	50	5	—	AF 2215 E0
38	54	6	AG 2228 E0	—
38	55	6	AG 2229 E1	AF 2229 E0
38	58	5	AG 2237 E0	—
38	58	8	AG 2239 A0	AF 2239 E0
38	64	5	—	AF 2253 E0
40	52	5	AG 2340 E0	AF 2340 F0
40	55	5	AG 2357 E1	AF 2357 E0
40	58	6	AG 2367 A0	AF 2367 E0
40	60	5	AG 2373 E0	AF 2373 E0
40	62	5	AG 2382 E0	AF 2382 E3
40	62	6	AG 2383 A0	AF 2383 E0
40	62	8	AG 2386 E0	AF 2386 E0
40	65	5	AG 2399 E0	AF 2399 E0
40	65	6	AG 2400 E0	AF 2400 E0
42	55	6	AG 2480 E1	AF 2480 E0
42	55	7	—	AF 2481 E0
42	60	7	AG 2492 F0	AF 2492 E0
42	65	9	AG 2504 A0	AF 2504 E0
45	60	6	AG 2640 E1	AF 2640 E0
45	62	7	AG 2649 A0	AF 2649 E0
45	65	5	—	AF 2655 E0

VC Type, VB Type

Material Nitrile (NBR)

● The sectional view on the right shows the typical profile of the seal type.

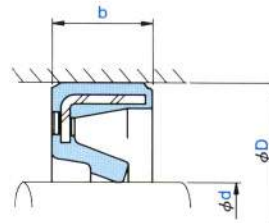

VC type

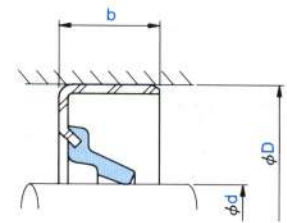

VB type

Dimensions			Part Number	Part Number
Shaft diameter d	Outside diameter D	Width b		
45	68	6	AG 2664 A0	AF 2664 E0
45	68	9	AG 2666 A0	AF 2666 E0
45	70	6	AG 2674 E0	—
45	72	6	AG 2682 E0	AF 2682 E0
48	62	6	AG 2772 E0	—
48	62	8	AG 2774 E0	—
48	65	7	AG 2779 E0	AF 2779 E0
48	70	6	AG 2787 A0	AF 2787 E2
50	65	6	AG 2835 E0	AF 2835 E0
50	68	7	AG 2846 A0	AF 2846 E0
50	72	5	AG 2859 E0	—
50	72	6	AG 2860 A0	AF 2860 E0
50	72	9	AG 2861 E0	—
50	80	6	AG 2883 E0	AF 2883 E0
50	80	7	AG 2884 E0	AF 2884 E0
52	65	6	AG 2954 E0	—
52	70	7	AG 2958 E0	AF 2958 E0
52	75	9	AG 2965 A0	—
55	70	6	AG 3034 E0	AF 3034 E2
55	72	7	AG 3038 A4	AF 3038 E0
55	74	6	—	AF 3044 E0
55	78	9	AG 3053 A0	—
56	70	6	AG 3088 E1	AF 3088 E0
58	72	6	AG 3143 E0	—
58	75	7	AG 3147 E2	AF 3147 E0
58	80	5	—	AF 3150 E0
58	80	6	AG 3151 E0	—
58	80	9	AG 3152 A0	AF 3152 E0
60	75	6	AG 3191 E1	AF 3191 E0
60	78	7	AG 3203 E0	AF 3203 G0
60	82	6	AG 3217 A4	AF 3217 E0
60	82	9	AG 3220 E0	AF 3220 E0
60	85	6	AG 3230 E1	AF 3230 E0
60	90	7	AG 3240 E0	AF 3240 E0
62	75	6	AG 3283 E1	—
62	85	6	AG 3293 A0	AF 3293 E0
63	80	7	AG 3315 E1	AF 3315 F0
65	85	9	AG 3393 E0	—
65	88	5	AG 3397 E3	—
65	88	6	AG 3398 A0	AF 3398 E0
68	90	7	AG 6761 A0	—

VC Type, VB Type

Material Nitrile (NBR)

● The sectional view on the right shows the typical profile of the seal type.

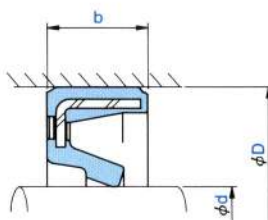

VC type

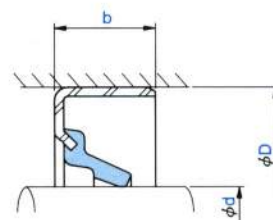

VB type

Dimensions			Part Number	Part Number
Shaft diameter d	Outside diameter D	Width b		
70	88	7	AG 3503 E0	—
70	90	10	AG 3512 E1	AF 3512 E0
70	92	5	AG 3515 E0	—
70	92	7	AG 3516 A0	AF 3516 E0
70	92	12	AG 3519 E0	—
70	95	7	AG 6762 A0	—
74	95	7	AG 3584 A0	—
75	100	7	AG 3613 A4	AF 3613 E0
75	100	8	AG 3614 E0	AF 3614 E0
80	95	6	AG 3723 E1	AF 3723 E0
80	100	7	AG 3729 E1	AF 3729 E0
80	105	7	AG 3739 A4	—
80	110	7	AG 3752 E1	—
85	100	9	AG 3830 E0	—
85	105	9	AG 3833 F0	—
85	110	7	AG 3939 A4	—
85	110	8	—	AF 3840 E0
90	115	5	AG 3926 E0	—
90	115	13	AG 3932 F0	—
95	115	9	AG 3982 E0	—
95	120	8	AG 3990 E0	AF 3990 E0
95	135	13	AG 4010 E0	—
100	125	8	AG 4059 E0	AF 4059 E1
105	150	12	—	AF 4166 E0
110	140	8	AG 4208 E2	—
110	150	15	—	AF 4225 E0
112	130	7	AG 4233 E0	—
115	135	8	AG 4275 E0	—
115	140	13	—	AF 4278 E0
120	150	14	—	AF 4346 E0
135	165	14	AG 4498 E0	—
140	165	15	—	AF 4539 E0
140	170	10	—	AF 4540 E0
140	170	14	AG 4542 E0	—
165	190	13	—	AF 4736 E1
195	220	15	—	AF 5018 E0
200	230	16	—	AF 5054 E2
220	255	12	AG 5206 E1	—
240	280	15	AG 5349 E0	—

NOK Standard Oil Seals

KC_{Type}, KB_{Type}

Nitrile rubber (NBR) oil seals

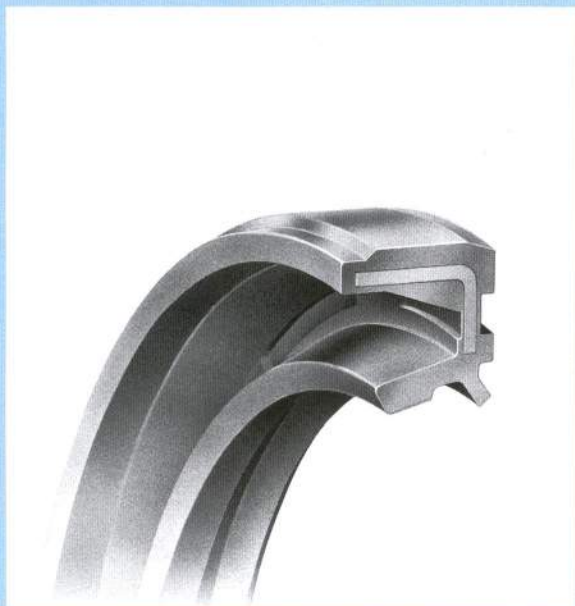

- When ordering, please indicate the NOK part number and the relevant dimensions.
- Check the Guide to Allowable Operating Conditions on pages E-6 and E-7 for relevant information on the seal selected before use.

Lip Material	NOK A727
--------------	----------

NOK Standard Oil Seals

TCV Type, TCN Type

Nitrile rubber (NBR) oil seal

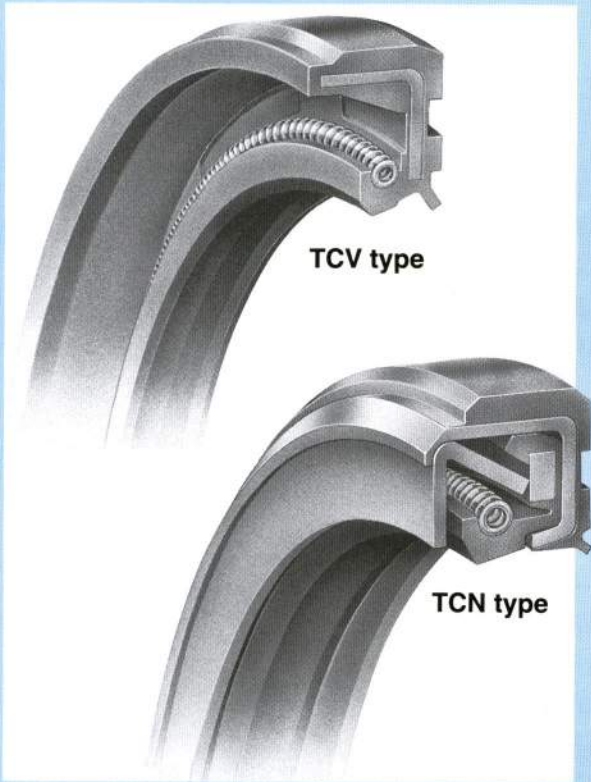

- When ordering, please indicate the NOK part number and the relevant dimensions.
- Check the Guide to Allowable Operating Conditions on pages E-6 and E-7 for relevant information on the seal selected before use.

Lip Material	NOK A795
--------------	----------

TCV_{Type}, TCN_{Type}

Material Nitrile (NBR)

● The sectional view on the right shows the typical profile of the seal type.

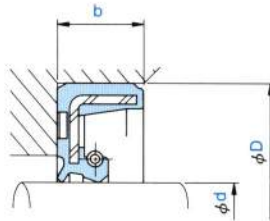

TCV type

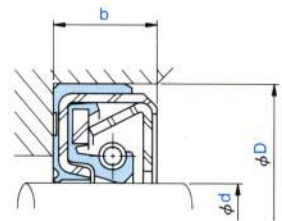

TCN type

Dimensions			Part Number	Part Number
Shaft diameter d	Outside diameter D	Width b		
7	20	7	AP 0090 E0	—
8	18	7	AP 0145 E0	—
8	22	7	AP 0158 F0	—
10	25	7	AP 0279 E0	—
12	25	7	AP 0382 E0	—
13	28	7	AP 0478 E0	—
14	28	7	AP 0526 F0	—
15	30	7	AP 0598 A0	—
16	30	7	AP 0687 F0	—
17	35	8	AP 0760 E0	—
18	35	8	AP 0829 E0	—
19	35	8	AP 0875 E0	—
20	32	8	AP 0997 E0	—
20	40	11	AP 1033 A0	—
22	35	8	AP 1127 E0	—
22	42	11	AP 1148 E0	—
23	42	11	AP 1224 E0	—
24	40	8	AP 1260 E0	—
25	40	8	AP 1314 H0	—
25	45	11	AP 1338 A0	AP 1338 F0
26	42	8	AP 1474 F0	—
27	47	11	AP 1518 F0	—
28	48	11	AP 1563 K0	AP 1563 J4
30	42	7	AP 1665 E0	—
30	50	11	AP 1709 A0	AP 1709 H4
32	52	11	AP 1904 G0	AP 1904 F3
34	54	11	AP 1978 F0	AP 1978 G1
35	55	11	AP 2085 A0	AP 2085 G1
38	58	11	AP 2240 A0	AP 2240 G4
40	62	11	AP 2388 A0	AP 2388 E5
42	65	12	AP 2507 G0	AP 2507 H2
45	68	12	AP 2668 A0	AP 2668 G4
48	70	12	AP 2791 F0	AP 2791 G0
50	72	12	AP 2864 A0	AP 2864 I3
52	75	12	AP 2967 F0	—
55	78	12	AP 3055 G0	AP 3055 F3
58	80	12	AP 3154 E0	—
60	82	12	AP 3222 G0	AP 3222 B6
62	85	12	AP 3297 F0	AP 3297 G3
65	90	13	—	AP 3409 F1

NOK Standard Oil Seals

TCV Type, TCN Type

Fluorocarbon rubber (FKM) oil seal

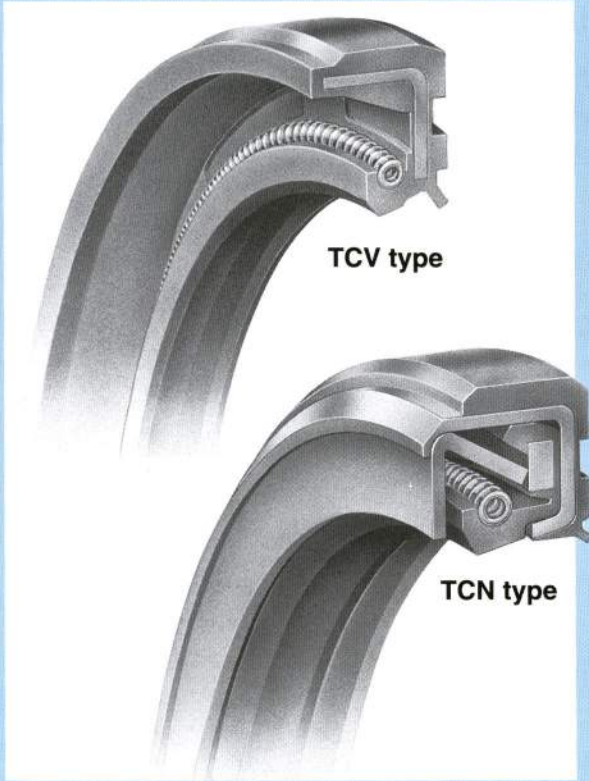

- When ordering, please indicate the NOK part number and the relevant dimensions.
- Check the Guide to Allowable Operating Conditions on pages E-6 and E-7 for relevant information on the seal selected before use.

Lip Material	NOK F548
--------------	----------

NOK Standard Oil Seals

TC4_{Type}, TB4_{Type}

Nitrile rubber (NBR) oil seal

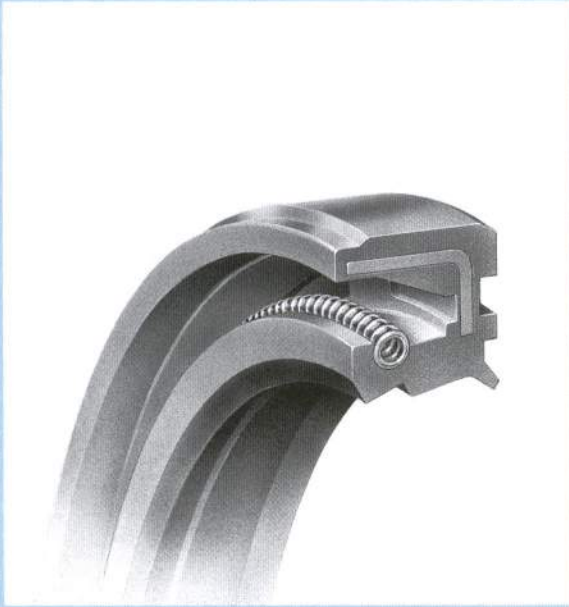

- When ordering, please indicate the NOK part number and the relevant dimensions.
- Check the Guide to Allowable Operating Conditions on pages E-6 and E-7 for relevant information on the seal selected before use.

Lip Material	NOK A795
--------------	----------

TC4 Type, TB4 Type

Material Nitrile (NBR)

● The sectional view on the right shows the typical profile of the seal type.

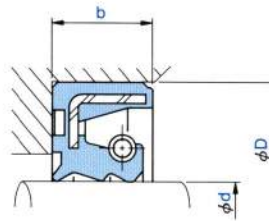

TC4 type

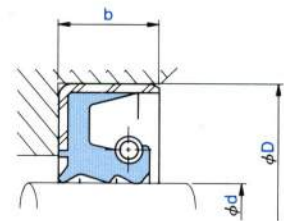

TB4 type

Dimensions			Part Number	Part Number
Shaft diameter d	Outside diameter D	Width b		
8	18	7	AR 0145 F2	—
10	20	7	AR 0260 F2	—
12	25	7	AR 0382 E1	—
14	24	7	AR 0515 G0	—
15	30	10	—	AR 0600 E1
16	30	7	—	AR 0687 E5
16	32	10	AR 0693 E1	—
17	38	7	—	AR 0768 E1
18	35	11	AR 0832 E2	—
20	35	7	AR 1012 F3	AR 1012 E2
20	40	10	—	AR 1032 E1
22	38	8	—	AR 1133 E2
22	40	10	AR 1140 E1	—
22	42	11	—	AR 1148 F2
25	38	7	AR 1306 F0	—
25	40	8	—	AR 1314 E2
25	45	10	—	AR 1337 E8
28	45	8	AR 1550 F1	AR 1550 E1
28	48	11	—	AR 1563 E1
30	50	11	AR 1709 F1	AR 1709 E0
32	52	11	—	AR 1904 E1
35	52	12	—	AR 2072 E2
35	55	11	—	AR 2085 E2
36	52	11	—	AR 2165 E1
38	55	8	AR 2230 E1	—
38	60	12	—	AR 2246 E1
40	55	9	—	AR 2361 E1
40	62	12	AR 2390 H1	AR 2390 E0
45	68	12	AR 2668 F1	AR 2668 E0
48	70	12	AR 2791 E1	AR 2791 F0
50	68	9	AR 2847 E1	—
50	72	12	—	AR 2864 E3
52	75	12	—	AR 2967 E0
55	72	9	—	AR 3040 E3
55	78	12	—	AR 3055 E2
55	80	14	—	AR 3063 E0
60	78	9	—	AR 3204 E1
60	82	12	—	AR 3222 E1
60	82	14	—	AR 3224 E0
65	88	12	—	AR 3400 E0



TC4 Type, TB4 Type

Material Nitrile (NBR)

● The sectional view on the right shows the typical profile of the seal type.

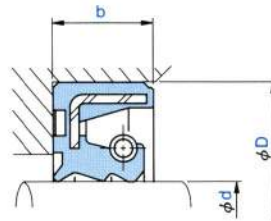

TC4 type

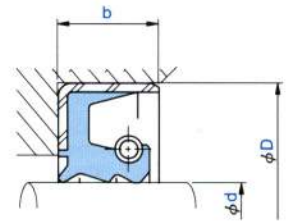

TB4 type

Dimensions			Part Number	Part Number
Shaft diameter d	Outside diameter D	Width b		
65	90	14	—	AR 3410 E0
68	95	13	—	AR 3463 F1
70	88	12	—	AR 3505 E1
70	95	14	—	AR 3528 E1
75	95	10	—	AR 3609 E0
75	100	14	—	AR 3619 F1
78	100	13	—	AR 3694 E1
80	100	14	—	AR 3735 E0
80	105	14	—	AR 3745 E1
80	110	13	—	AR 3756 E0
85	110	14	—	AR 3843 E0
90	115	14	—	AR 3933 E0
95	120	13	—	AR 3994 E1
100	125	14	—	AR 4064 E0
105	135	14	—	AR 4153 E1
110	135	14	—	AR 4207 E2
110	140	14	—	AR 4212 E2
120	145	14	—	AR 4336 E1
120	150	14	AR 4346 G1	AR 4346 F1
125	150	14	—	AR 4396 E1
125	155	14	AR 4399 E1	—
130	155	14	—	AR 4445 E0
140	165	14	—	AR 4538 E2
145	175	14	—	AR 4581 E1
150	180	14	AR 4624 F1	AR 4624 G1
160	185	14	—	AR 4708 E0
160	190	14	AR 4711 E1	—
190	215	14	—	AR 4971 E1
220	245	14	—	AR 5201 E0
230	270	20	—	AR 5290 E1
250	290	20	—	AR 5407 E1

NOK General Oil Seals

TCJ Type (special PTFE)

Nitrile rubber (NBR) oil seal

Acrylic rubber (ACM) oil seal



H

- When ordering, please indicate the NOK part number and the relevant dimensions.
- Check the Guide to Allowable Operating Conditions on pages E-8 and E-9 for relevant information on the seal selected before use.

Lip Material	NBR : NOK A103 + NOK 31BF ACM : NOK T302 + NOK 31BF
Reference	The lip of this PTFE seal is easily scratched. Handle with care. Be sure to refer to Chapter F for information on the design of the shaft and housing.

TCJ Type

H

Material	Nitrile (NBR) + (PTFE)
	Acrylic (ACM) + (PTFE)

●The sectional view on the right shows the typical profile of the seal type.

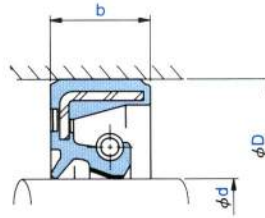

Dimensions			Part Number	
Shaft diameter d	Outside diameter D	Width b	Nitrile rubber (NBR)	Acrylic rubber (ACM)
20	35	8	GJ 1013 P1	GJ 1013 Q0
20	40	11	GJ 1033 P0	—
25	40	8	GJ 1314 P0	GJ 1314 Q0
25	45	11	GJ 1338 P0	GJ 1338 Q0
30	45	8	GJ 1679 P0	GJ 1679 Q0
30	50	11	GJ 1709 P0	GJ 1709 Q0
35	50	8	GJ 2057 P0	GJ 2057 Q0
35	55	11	GJ 2085 P0	GJ 2085 Q0
40	58	8	GJ 2369 P0	GJ 2369 Q0
40	62	11	GJ 2388 P0	GJ 2388 Q0
45	62	9	GJ 2651 P0	GJ 2651 Q0
45	68	12	—	GJ 2668 Q0
50	68	9	GJ 2847 P0	GJ 2847 Q0
50	72	12	GJ 2864 P0	GJ 2864 Q0
55	72	9	GJ 3040 P0	GJ 3040 Q0
55	78	12	GJ 3055 P0	GJ 3055 Q0
60	82	12	GJ 3222 P0	GJ 3222 Q0
65	88	12	GJ 3400 P0	GJ 3400 Q0
70	92	12	GJ 3519 P0	GJ 3519 Q0
70	95	13	GJ 3527 P0	—
75	100	13	GJ 3618 P0	GJ 3618 Q0
80	105	13	GJ 3744 P0	—
85	110	13	GJ 3842 P0	GJ 3842 Q0
90	115	13	GJ 3932 P0	—
95	120	13	GJ 3994 P0	GJ 3994 Q0
100	125	13	GJ 4063 P0	GJ 4063 Q0
105	135	14	GJ 4153 P0	GJ 4153 Q0
110	140	14	GJ 4212 P0	GJ 4212 Q0
115	145	14	GJ 4282 P0	GJ 4282 Q0
120	150	14	GJ 4346 P0	GJ 4346 Q0

NOK General Oil Seals

SA1J_{Type,}
VAJ_{Type,} **KA3J**_{Type}
(PTFE) seal

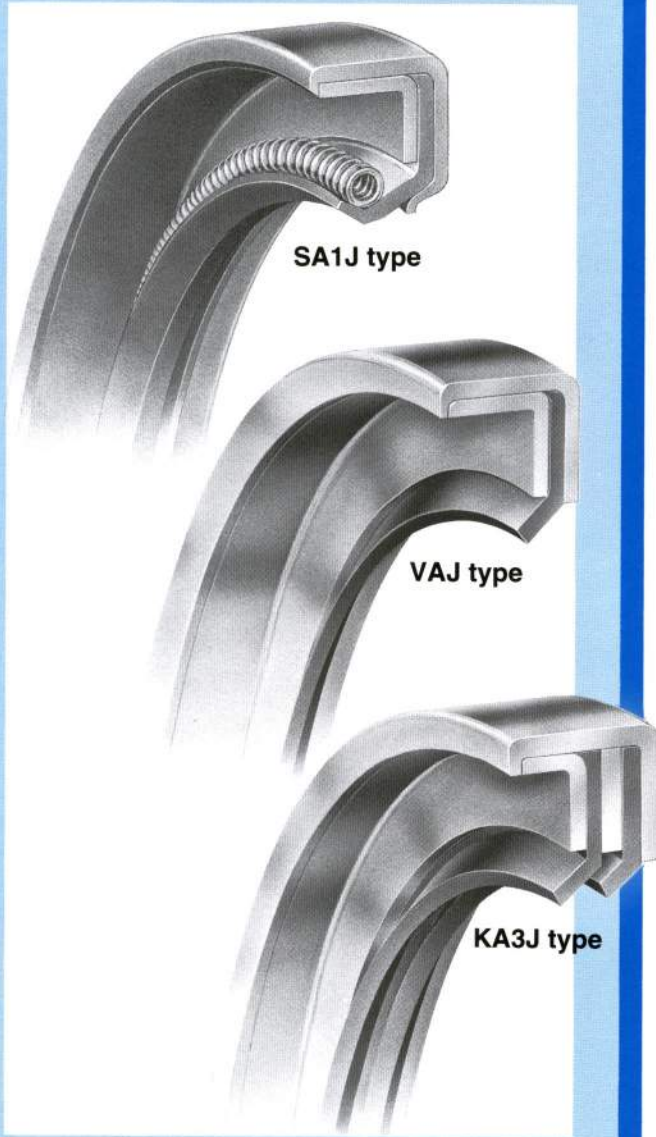

- When ordering, please indicate the NOK part number and the relevant dimensions.
- Check the Guide to Allowable Operating Conditions on pages E-8 and E-9 for relevant information on the seal selected before use.

Lip Material	NOK 31BF
Reference	The lip of this PTFE seal is easily scratched. Handle with care. Be sure to refer to Chapter F for information on the design of the shaft and housing.

SA1J Type, VAJ Type, KA3J Type

Material (PTFE)

●The sectional view on the right shows the typical profile of the seal type.

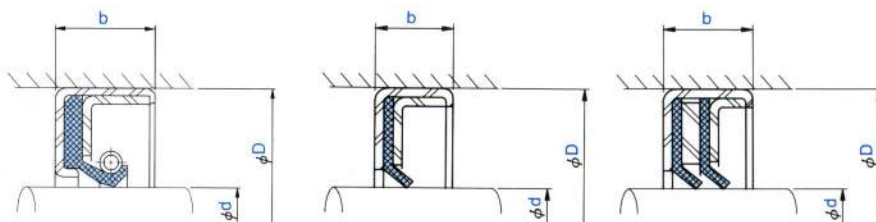

SA1J type

VAJ type

KA3J type

Dimensions			Part Number	Part Number	Part Number
Shaft diameter d	Outside diameter D	Width b			
20	40	11	—	GJ 1033 E0	GJ 1033 F0
25	45	11	—	—	GJ 1338 H0
28	48	11	—	—	GJ 1563 F0
30	50	11	GJ 1709 H0	GJ 1709 I0	GJ 1709 E1
32	52	11	—	—	GJ 1904 G0
35	55	11	GJ 2085 F0	GJ 2085 H0	GJ 2085 I0
40	62	11	—	GJ 2388 H0	GJ 2388 I0
42	65	12	—	GJ 2507 F0	GJ 2507 G0
45	68	12	GJ 2668 F2	GJ 2668 I0	GJ 2668 J0
50	72	12	GJ 2864 H2	GJ 2864 I0	GJ 2864 J0
55	78	12	GJ 3055 I1	GJ 3055 K0	GJ 3055 F0
60	82	12	GJ 3222 J2	GJ 3222 K0	GJ 3222 I0
62	85	12	GJ 3297 H0	—	—
65	90	13	GJ 3409 F0	GJ 3409 G0	GJ 3409 H0
70	95	13	GJ 3527 F0	GJ 3527 H0	GJ 3527 G0
75	100	13	GJ 3618 J1	GJ 3618 K0	GJ 3618 L0
80	105	13	GJ 3744 J5	GJ 3744 G1	GJ 3744 H0
85	110	13	GJ 3842 J1	—	GJ 3842 I0
90	115	13	GJ 3932 E2	GJ 3932 J0	GJ 3932 K0
95	120	13	GJ 3994 G4	—	GJ 3994 K0
100	125	13	GJ 4063 J0	GJ 4063 H0	GJ 4063 I0
105	135	14	GJ 4153 L0	GJ 4153 E2	—
110	140	14	GJ 4212 T0	—	—
115	145	14	GJ 4282 F2	—	GJ 4282 H0
120	150	14	GJ 4346 S0	—	GJ 4346 I0
125	155	14	GJ 4399 H0	—	GJ 4399 G0
130	160	14	GJ 4451 J0	GJ 4451 G0	GJ 4451 H0
135	165	14	GJ 4498 J1	GJ 4498 I0	—
140	170	14	GJ 4542 I0	—	GJ 4542 F1
145	175	14	GJ 4581 H0	—	—
150	180	14	GJ 4624 J0	GJ 4624 I0	—
160	190	16	GJ 4713 H0	GJ 4713 F0	—
170	200	16	GJ 4795 G0	—	—
180	210	16	GJ 4898 H0	—	GJ 4898 E0
190	225	16	GJ 4983 G0	—	—
200	240	20	GJ 5068 I0	—	—

NOK General Oil Seals

DC Type, DB Type

Nitrile rubber (NBR) oil seal
Acrylic rubber (ACM) oil seal

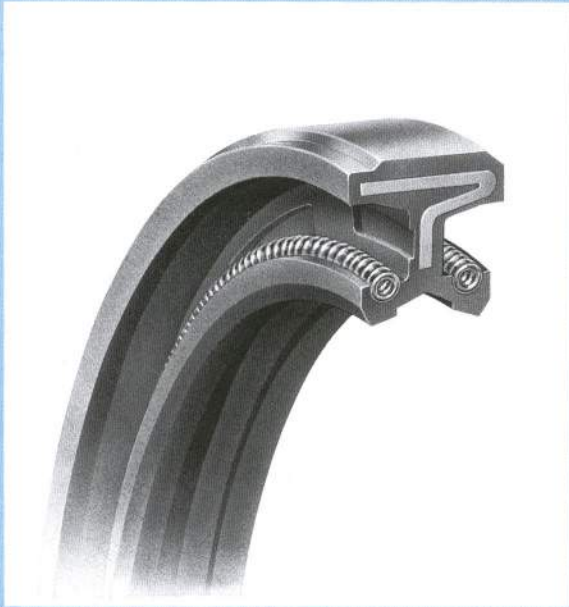

H

- When ordering, please indicate the NOK part number and the relevant dimensions.
- Check the Guide to Allowable Operating Conditions on pages E-8 and E-9 for relevant information on the seal selected before use.

Lip Material	NBR : NOK A727 ACM : NOK T303
Reference	If you wish to use the D type oil seal with non-standard dimensions, use two S Type oil seals together instead.

NOK General Oil Seals

OC_{Type}

Nitrile rubber (NBR) oil seal



H

- When ordering, please indicate the NOK part number and the relevant dimensions.
- Check the Guide to Allowable Operating Conditions on pages E-8 and E-9 for relevant information on the seal selected before use.

Lip Material	NOK A727
Reference	The seal lip edge of the OC type seal contacts the ID of the housing bore. Refer to Chapter F for details on machining the bore and the required surface roughness.

NOK General Oil Seals

QLFY_{Type}

Nitrile rubber (NBR) oil seal



H

- When ordering, please indicate the NOK part number and the relevant dimensions.
- Check the Guide to Allowable Operating Conditions on pages E-8 and E-9 for relevant information on the seal selected before use.

Lip Material	NOK A571
--------------	----------

NOK General Oil Seals

VR_{Type}

Nitrile rubber (NBR) oil seal

Fluorocarbon rubber (FKM) oil seal



H

- When ordering, please indicate the NOK part number and the relevant dimensions.
- Check the Guide to Allowable Operating Conditions on pages E-8 and E-9 for relevant information on the seal selected before use.

Lip Material	NBR : NOK A134 ACM : NOK F129
--------------	----------------------------------

VR Type

Material	Nitrile (NBR)
	Fluorocarbon (FKM)

● The sectional view on the right shows the typical profile of the seal type.

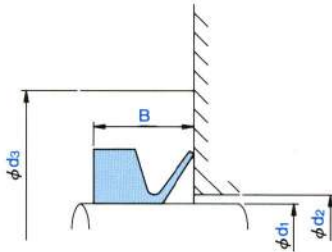

Note: This oil seal may be used with shaft diameters in the ranges shown. However, we recommend using it at the recommended nominal shaft diameter.

Nominal number	Recommended shaft diameter d_1	(See Note) Usable shaft diameter	Area required for seal			Part Number				
			Width B	Maximum diameter d_2	Required minimum face diameter b_3	Nitrile rubber (NBR)	Fluorocarbon rubber (FKM)			
VR 3A	3	2.7~3.5	2.5	$d_1 + 1$	$d_1 + 4$	BM 1201 A0	BM 1201 A3			
VR 4A	4	3.5~4.5	3	$d_1 + 1$	$d_1 + 6$	BM 1202 A0	BM 1202 A3			
VR 5A	5	4.5~5.5				BM 1203 A0	BM 1203 A3			
VR 6A	6	5.5~6.5				BM 1204 A0	BM 1204 A3			
VR 7A	7	6.5~7.5				BM 1205 A0	BM 1205 A3			
VR 8A	8	7.5~8.5				BM 1206 A0	BM 1206 A3			
VR 10A	10	9.5~11.5	4.5	$d_1 + 2$	$d_1 + 9$	BM 1207 A0	BM 1207 A3			
VR 12A	12	11.5~12.5				BM 1208 A0	BM 1208 A3			
VR 13A	13	12.5~13.5				BM 1209 A0	BM 1209 A3			
VR 14A	14	13.5~15.5				BM 1210 A0	BM 1210 A3			
VR 16A	16	15.5~17.5				BM 1211 A0	BM 1211 A3			
VR 18A	18	17.5~19				BM 1212 A0	BM 1212 A3			
VR 20A	20	19~21				6	$d_1 + 3$	$d_1 + 12$	BM 1213 A0	BM 1213 A3
VR 22A	22	21~24	BM 1214 A0	BM 1214 A3						
VR 25A	25	24~27	BM 1215 A0	BM 1215 A3						
VR 28A	28	27~29	BM 1216 A0	BM 1216 A3						
VR 30A	30	29~31	BM 1217 A0	BM 1217 A3						
VR 32A	32	31~33	BM 1218 A0	BM 1218 A3						
VR 35A	35	33~36	BM 1219 A0	BM 1219 A3						
VR 38A	37	36~38	BM 1220 A0	BM 1220 A3						
VR 40A	40	38~43	7	$d_1 + 3$	$d_1 + 15$				BM 1221 A0	BM 1221 A3
VR 45A	45	43~48							BM 1222 A0	BM 1222 A3
VR 50A	50	48~53				BM 1223 A0	BM 1223 A3			
VR 55A	55	53~58				BM 1224 A0	BM 1224 A3			
VR 60A	60	58~63				BM 1225 A0	BM 1225 A3			
VR 65A	65	63~68				BM 1226 A0	BM 1226 A3			
VR 70A	70	68~73				9	$d_1 + 4$	$d_1 + 18$	BM 1227 A0	BM 1227 A3
VR 75A	75	73~78							BM 1228 A0	BM 1228 A3
VR 80A	80	78~83	BM 1229 A0	BM 1229 A3						
VR 85A	85	83~88	BM 1230 A0	BM 1230 A3						
VR 90A	90	88~93	BM 1231 A0	BM 1231 A3						
VR 95A	95	93~98	BM 1232 A0	BM 1232 A3						
VR100A	100	98~105	BM 1233 A0	BM 1233 A3						
VR110A	110	105~115	10.5	$d_1 + 4$	$d_1 + 21$	BM 1234 A0	BM 1234 A3			
VR120A	120	115~125				BM 1235 A0	BM 1235 A3			
VR130A	130	125~135				BM 1236 A0	BM 1236 A3			
VR140A	140	135~145				BM 1237 A0	BM 1237 A3			
VR150A	150	145~155				BM 1238 A0	BM 1238 A3			
VR160A	160	155~165	12	$d_1 + 5$	$d_1 + 24$	BM 1239 A0	BM 1239 A3			
VR170A	170	165~175				BM 1240 A0	BM 1240 A3			

VR Type

Material	Nitrile (NBR)
	Fluorocarbon (FKM)

● The sectional view on the right shows the typical profile of the seal type.

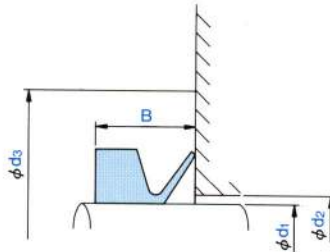

Note: This oil seal may be used with shaft diameters in the ranges shown. However, we recommend using it at the recommended nominal shaft diameter.

Nominal number	Recommended shaft diameter d_1	(See Note) Usable shaft diameter	Area required for seal			Part Number	
			Width B	Maximum diameter d_2	Required minimum face diameter b_3	Nitrile rubber (NBR)	Fluorocarbon rubber (FKM)
VR 180A	180	175~185	12	$d_1 + 5$	$d_1 + 24$	BM 1241 A0	BM 1241 A3
VR 190A	190	185~195				BM 1242 A0	BM 1242 A3
VR 199A	199	195~210				BM 1243 A0	BM 1243 A3
VR 200A	200	190~210				BM 1244 A0	BM 1244 A3
VR 220A	220	210~235				BM 1245 A0	BM 1245 A3
VR 250A	250	235~265				BM 1246 A0	BM 1246 A3
VR 275A	275	265~290				BM 1247 A0	BM 1247 A3
VR 300A	300	290~310				BM 1248 A0	BM 1248 A3
VR 325A	325	310~335				BM 1249 A0	BM 1249 A3
VR 350A	350	335~365				BM 1250 A0	BM 1250 A3
VR 375A	375	365~390				BM 1251 A0	BM 1251 A3
VR 400A	400	390~430				BM 1252 A0	BM 1252 A3
VR 450A	450	430~480				BM 1253 A0	BM 1253 A3
VR 500A	500	480~530				BM 1254 A0	BM 1254 A3
VR 550A	550	530~580				BM 1255 A0	BM 1255 A3
VR 600A	600	580~630				BM 1256 A0	BM 1256 A3
VR 650A	650	630~665				BM 1257 A0	BM 1257 A3
VR 700A	700	665~705	BM 1258 A0	BM 1258 A3			
VR 725A	725	705~745	20	$d_1 + 10$	$d_1 + 45$	BM 1259 A0	BM 1259 A3
VR 750A	750	745~785				BM 1260 A0	BM 1260 A3
VR 800A	800	785~830				BM 1261 A0	BM 1261 A3
VR 850A	850	830~875				BM 1262 A0	BM 1262 A3
VR 900A	900	875~920				BM 1263 A0	BM 1263 A3
VR 950A	950	920~965				BM 1264 A0	BM 1264 A3
VR1000A	1000	965~1015				BM 1265 A0	BM 1265 A3
VR1050A	1050	1015~1065				BM 1266 A0	BM 1266 A3
VR1100A	1100	1065~1115				BM 1267 A0	BM 1267 A3
VR1150A	1150	1115~1165				BM 1268 A0	BM 1268 A3
VR1200A	1200	1165~1215				BM 1269 A0	BM 1269 A3
VR1250A	1250	1215~1270				BM 1270 A0	BM 1270 A3
VR1300A	1300	1270~1320				BM 1271 A0	BM 1271 A3
VR1350A	1350	1320~1370				BM 1272 A0	BM 1272 A3
VR1400A	1400	1370~1420				BM 1273 A0	BM 1273 A3
VR1450A	1450	1420~1470				BM 1274 A0	BM 1274 A3
VR1500A	1500	1470~1520				BM 1275 A0	BM 1275 A3
VR1550A	1550	1520~1570	BM 1276 A0	BM 1276 A3			
VR1600A	1600	1570~1620	BM 1277 A0	BM 1277 A3			
VR1650A	1650	1620~1670	BM 1278 A0	BM 1278 A3			
VR1700A	1700	1670~1720	BM 1279 A0	BM 1279 A3			
VR1750A	1750	1720~1770	BM 1280 A0	BM 1280 A3			

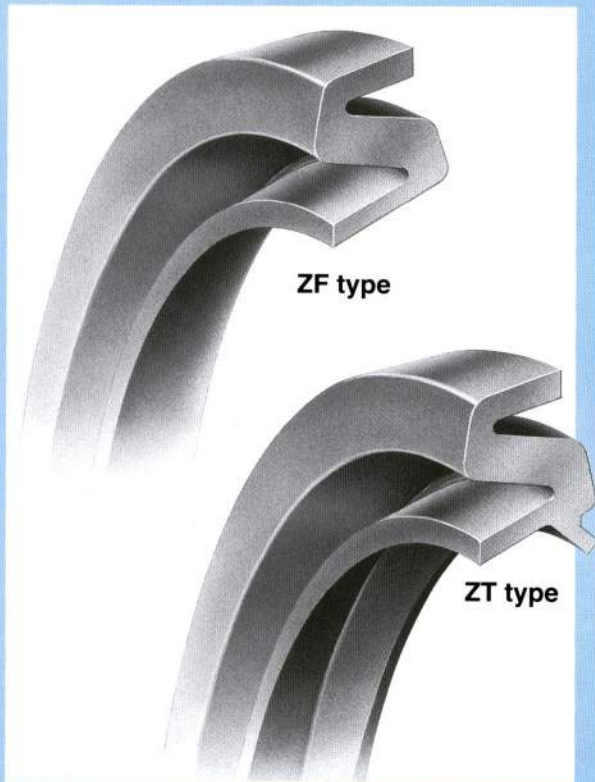

- When ordering, please indicate the NOK part number and the relevant dimensions.
- Check the Guide to Allowable Operating Conditions on pages E-8 and E-9 for relevant information on the seal selected before use.

Lip Material	NOK A103
--------------	----------

ZF_{Type}

Material Nitrile (NBR)

● The sectional view on the right shows the typical profile of the seal type.

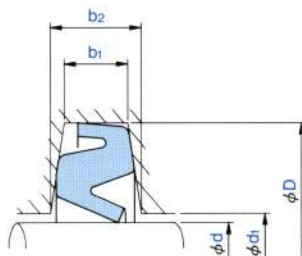

Nominal number	Shaft diameter d	Groove dimensions				Part Number	Nominal number for plumber block
		D	d ₁	b ₁	b ₂		
1	10	21	11	3	4.2	AZ 0264 E0	—
2	12	23	13	3	4.2	AZ 0373 E0	—
3	15	26	16	3	4.2	AZ 0589 F0	—
4	17	28	18	3	4.2	AZ 0733 F0	SN504, SN604
5	19.05	31	20	3	4.4	AZ 0906 E0	S505E, S605E
5	20	31	21.5	3	4.2	AZ 0992 G0	SN505, SN605
6	25	38	26.5	4	5.4	AZ 1304 H0	SN506, SN606
7	28.58	43	29.6	4	5.6	AZ 1602 E0	S507S, S607S
7	30	43	31.5	4	5.4	AZ 1670 H0	SN507, SN607
7	30.16	43	31.2	4	5.4	AZ 1670 H0	S507A, S607A
8	31.75	48	32.8	4	5.9	AZ 1833 E0	S508E, S608E
8	34.92	48	35.9	4	5.5	AZ 2045 G0	S508S, S608S
8	35	48	36.5	4	5.4	AZ 2045 G0	SN508, SN608
9	38.1	53	39.1	4	5.7	AZ 2275 E0	SS509E, S609E
9	40	53	41.5	4	5.4	AZ 2347 G0	SN509E, SN609
10	44.45	58	45.5	4	5.5	AZ 2578 E0	S510E, S610E
10	45	58	46.5	4	5.4	AZ 2636 G0	SN510, SN610
11	49.21	67	50.2	5	7.1	AZ 2845 F0	S511A, S611A
11	50	67	51.5	5	6.9	AZ 2845 F0	SN511, SN611
11	50.8	67	51.8	5	6.9	AZ 2914 E0	S511E, S611E
12	55	72	56.5	5	6.9	AZ 3038 G0	SN512, SN612
13	57.15	77	58.7	5	7.2	AZ 3126 E0	S513E, S613E
13	60	77	62	5	6.8	AZ 3199 G0	SN513, SN613
13	60.32	77	61.8	5	6.9	AZ 3199 G0	—
15	63.5	82	65	5	7.1	AZ 3334 E0	S515E, S615E
15	65	82	67	5	6.8	AZ 3388 F0	SN515, SN615
16	69.85	89	71.4	6	8.2	AZ 3508 F0	S516E, S616E
16	70	89	72	6	8.1	AZ 3508 F0	SN516, SN616
17	74.61	94	76.1	6	8.2	AZ 3606 F0	S517A, S617A
17	75	94	77	6	8.1	AZ 3606 F0	SN517, SN617
18	79.38	99	80.9	6	8.2	AZ 3727 F0	S518S, S618S
18	80	99	82	6	8.1	AZ 3727 F0	SN518, S618
19	85	104	87	6	8.1	AZ 3832 F0	S619
20	88.9	111	90.9	7	9.5	AZ 3887 E0	S520E, S620E
20	90	111	92	7	9.3	AZ 3923 F0	SN520, S620
21	95	116	97	7	9.3	AZ 3987 E0	—
21	95.25	116	97.2	7	9.3	AZ 3987 E0	—
22	100	125	102	8	10.8	AZ 4061 F0	SN522, S622
22	100.01	125	102	8	10.8	AZ 4061 F0	S522A, S622A
23	105	130	107	8	10.8	AZ 4149 E0	—

ZF Type

Material Nitrile (NBR)

● The sectional view on the right shows the typical profile of the seal type.

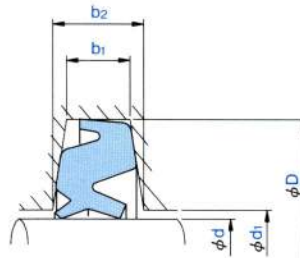

Nominal number	Shaft diameter d	Groove dimensions				Part Number	Nominal number for plumber block
		D	d ₁	b ₁	b ₂		
3	15	26	16	3	4.2	AZ 0589 G0	—
5	20	31	21.5	3	4.2	AZ 0992 E0	SN505, SN605
6	25	38	26.5	4	5.4	AZ 1304 E0	SN506, SN606
7	30	43	31.5	4	5.4	AZ 1670 E0	SN507, SN607
8	35	48	36.5	4	5.4	AZ 2045 E0	SN508, SN608
9	40	53	41.5	4	5.4	AZ 2347 I0	SN509, SN609
10	45	58	46.5	4	5.4	AZ 2636 F0	SN510, SN610
11	50	67	51.5	5	6.9	AZ 2845 E0	SN511, SN611
12	55	72	56.5	5	6.9	AZ 3038 F0	SN512, SN612
13	60	77	62	5	6.8	AZ 3199 F0	SN513, SN613
15	65	82	67	5	6.8	AZ 3388 E0	SN515, SN615
16	70	89	72	6	8.1	AZ 3508 E0	SN516, SN616
17	75	94	77	6	8.1	AZ 3606 E0	SN517, SN617
18	80	99	82	6	8.1	AZ 3727 E0	SN518, S618
19	85	104	87	6	8.1	AZ 3832 E0	S619
20	90	111	92	7	9.3	AZ 3923 E0	SN520, S620
21	95	116	97	7	9.3	AZ 3988 E1	—
22	100	125	102	8	10.8	AZ 4061 E0	SN522, S622
23	105	130	107	8	10.8	AZ 4149 F0	—
24	110	135	113	8	10.7	AZ 4206 E0	S524, S624
26	115	140	118	8	10.7	AZ 4276 E0	SN526, S626
27	120	149	123	9	12.2	AZ 4342 E0	—
28	125	154	128	9	12.2	AZ 4397 F0	SN528, S628
29	130	159	133	9	12.2	AZ 4448 F0	—
30	135	164	138	9	12.2	AZ 4497 E0	SN530, S630
32	140	173	143	10	13.7	AZ 4549 F0	SN532, S632
34	150	183	153	10	13.7	AZ 4629 E0	SD534, SD3134
36	160	193	163	10	13.7	AZ 4716 H0	SD536, SD3136
38	170	203	173	10	13.7	AZ 4799 E0	SD538, SD3138
40	180	213	183	10	13.7	AZ 4902 E0	SD540, SD3140
42	190	223	193	10	13.7	AZ 4980 F0	—
44	200	240	203	11	15.5	AZ 5064 F0	SD544, SD3144
48	220	260	223	11	15.5	AZ 5213 F0	SD548, SD3148
52	240	286	243	12	17.3	AZ 5355 G0	SD552, SD3152

NOK General Oil Seals

SBB Type, Large-diameter SB Type

Nitrile rubber (NBR) oil seal

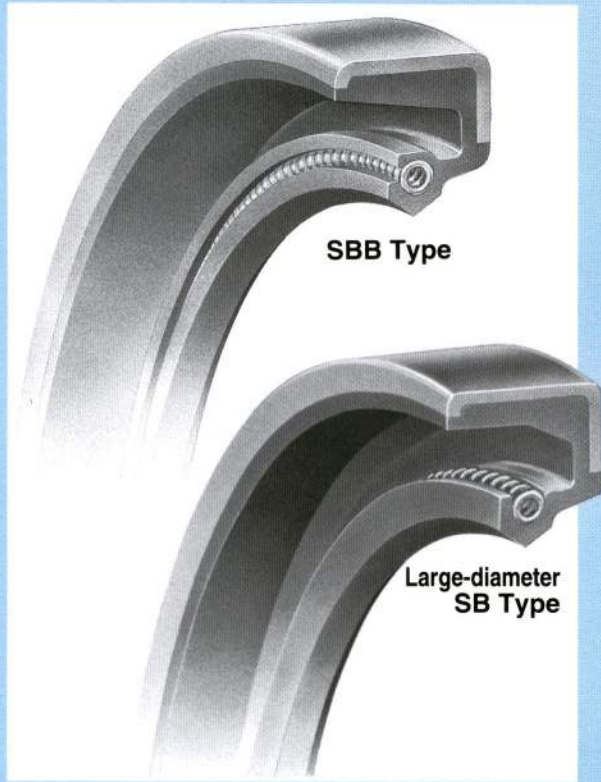

- When ordering, please indicate the NOK part number and the relevant dimensions.
- Check the Guide to Allowable Operating Conditions on pages E-10 and E-11 for relevant information on the seal selected before use.

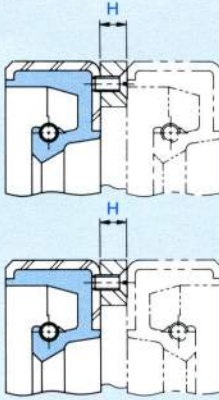
Lip Material	NOK A941								
Special order	<p>When ordering an oil seal with an attached spacer, please indicate the spacer width (H) after the NOK part number.</p> <p>Example: AB 5660 A0 Spacer attached (H=4)</p> <p>Quantity of spacers</p> <table border="1" data-bbox="548 1802 1027 1986"> <thead> <tr> <th>Nominal outside diameter of oil seal</th> <th>Number of spacers (equally spaced)</th> </tr> </thead> <tbody> <tr> <td>Up to 500</td> <td>4</td> </tr> <tr> <td>Over 500 to 800</td> <td>6</td> </tr> <tr> <td>Over 800</td> <td>8</td> </tr> </tbody> </table> 	Nominal outside diameter of oil seal	Number of spacers (equally spaced)	Up to 500	4	Over 500 to 800	6	Over 800	8
Nominal outside diameter of oil seal	Number of spacers (equally spaced)								
Up to 500	4								
Over 500 to 800	6								
Over 800	8								

SBB Type, Large-diameter SB Type

Material Nitrile (NBR)

● The sectional view on the right shows the typical profile of the seal type.

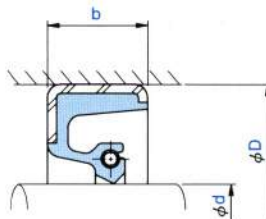

SBB Type

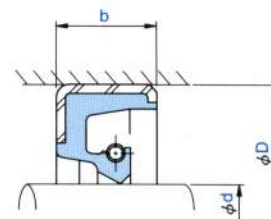

Large-diameter SB Type

Dimensions			Part Number	Part Number
Shaft diameter d	Outside diameter D	Width b		
304.80	355.60	25.4	—	AB 5653 E0
305	355	23	—	AB 5660 A0
310	370	25	AB 5675 A0	—
311.15	349.25	17.5	AB 5681 E0	—
315	355.60	16	—	AB 5688 E0
317.50	355.60	23	AB 5702 E0	—
320	358	20	—	AB 5709 E0
320	360	25	AB 5712 A0	—
320	380	25	—	AB 5718 A0
320.68	371.48	25.4	AB 5726 A0	—
325	375	25	—	AB 5737 A0
330	370	20	AB 5746 A0	—
330	390	25	—	AB 5753 A0
340	380	20	—	AB 9104 E0
340	400	25	—	AB 5784 A0
342.90	381.00	17.5	AB 5795 E0	—
350	390	20	AB 5814 E0	—
350	400	25	AB 5817 E0	—
350	410	25	—	AB 5822 E4
360	400	17	AB 5841 A0	—
360	420	25	—	AB 5846 A0
361.95	412.75	22.2	AB 5850 E0	—
365	405	18	—	AB 5855 E0
370	415	20	AB 5866 A0	—
370	430	25	AB 5868 E0	—
375	420	18	—	AB 5876 A5
380	440	25	AB 5888 A0	—
390	430	18	AB 9434 E0	—
390	450	25	—	AB 5909 A0
395	430	18	—	AB 5917 A5
400	450	15.6	—	AB 9388 E0
400	460	25	—	AB 5930 A0
400.05	438.15	17.5	AB 5935 E1	—
406.40	457.20	23	AB 5947 E1	—
410	450	20	AB 5952 A0	—
410	470	25	AB 5955 E2	—
415	475	23	—	AB 9406 E1
419.10	457.20	19	AB 5965 E0	—
420	470	20	—	AB 5971 E0
420	480	25	AB 5978 A0	—

SBB Type, Large-diameter SB Type

Material Nitrile (NBR)

● The sectional view on the right shows the typical profile of the seal type.

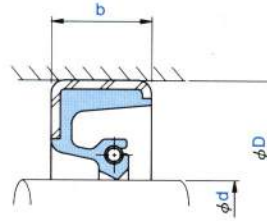

SBB Type

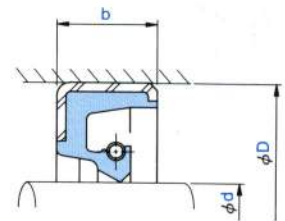

Large-diameter SB Type

Dimensions			Part Number	Part Number
Shaft diameter d	Outside diameter D	Width b		
430	470	20	AB 5993 A0	—
430	480	25	—	AB 5994 A9
438.15	476.25	19	AB 6014 E0	—
440	480	20	—	AB 6022 E0
440	490	25	—	AB 6025 A0
440	500	25	AB 6026 A0	—
450	480	17.5	—	AB 6046 E0
450	510	25	AB 6057 A0	—
454.02	504.82	19	—	AB 6062 E0
460	520	25	AB 6079 A0	—
469.90	520.70	23	—	AB 6092 E0
470	520	22	—	AB 9444 E0
470	530	25	AB 6096 A0	—
480	530	22	—	AB 6107 E1
480	540	25	—	AB 6111 A0
482.60	520.70	19	AB 6115 E1	—
490	550	25	—	AB 6125 E3
500	540	20	AB 6141 E0	—
500	560	25	AB 6144 A0	—
510	560	25	AB 6159 A0	—
520	560	20	AB 6166 A0	—
520	580	25	—	AB 6173 A0
520.70	571.50	22.2	AB 6175 E0	—
530	580	22	—	AB 6183 E0
540	590	25	—	AB 6193 A0
546.10	596.90	20.6	AB 6199 E5	—
550	610	25	—	AB 6207 A0
558.80	609.60	22.2	AB 6214 E0	—
560	610	22	AB 6223 A0	—
560	620	25	AB 6226 E0	—
570	620	22	AB 6235 A0	—
570	630	25	AB 6236 A0	—
580	640	25	—	AB 6245 A0
600	660	25	—	AB 6267 A0
610	670	23	AB 6281 A0	—
620	670	25	—	AB 6284 A0
620	680	23	—	AB 9528 E0
622.30	673.10	22.2	—	AB 6288 E0
630	670	20	AB 6292 A0	—
635	685	25	AB 6301 A0	—



SBB Type, Large-diameter SB Type

Material Nitrile (NBR)

● The sectional view on the right shows the typical profile of the seal type.

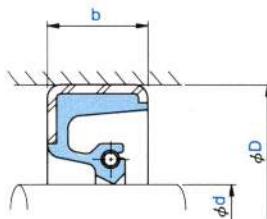

SBB Type

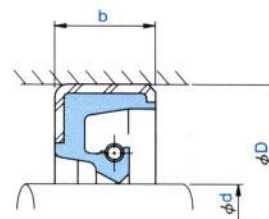

Large-diameter SB Type

Dimensions			Part Number	Part Number
Shaft diameter d	Outside diameter D	Width b		
640	690	25	—	AB 6303 A0
650	710	25	AB 6313 A0	—
650	720	25	—	AB 6315 A0
660.40	711.20	22.2	AB 6323 E1	—
670	720	25	—	AB 6330 E5
673.10	711.20	19	AB 6335 E0	—
685	745	25	—	AB 9001 E3
685.80	736.60	22.2	—	AB 6340 E0
690	730	20	—	AB 9036 E4
698.50	749.30	22.2	—	AB 6353 E0
700	750	20	—	AB 6356 E7
710	760	25	AB 6366 A0	—
710	770	25	AB 6369 A0	—
711.20	762.00	22.2	AB 6375 E0	—
720	768	22	—	AB 6384 E0
723.90	774.70	22.2	AB 6388 E0	—
730	790	25	—	AB 6392 A0
735	795	25	—	AB 6394 A0
740	790	25	AB 6398 A0	—
749.30	825.50	22.2	AB 6406 E0	—
750	800	25	—	AB 6407 E5
760	813	22	—	AB 6419 A0
774.70	825.50	22.2	AB 6437 E0	—
780	830	25	—	AB 6446 A0
800	870	25	—	AB 6459 A0
806.45	857.25	22.2	AB 6463 E0	—
810	870	25	—	AB 6465 A0
838.20	889.00	22.2	—	AB 6483 E0
840	910	25	—	AB 6485 A0
850	900	25	AB 6488 A0	—
850.90	914.40	22.2	AB 6496 E0	—
870	920	25	AB 6507 A0	—
876.30	927.10	22.2	AB 6512 E0	—
882.65	933.45	22.2	—	AB 6515 E2
890	950	25	AB 6519 A0	—
900	950	25	AB 6527 A0	—
914.40	977.90	25.4	—	AB 6535 E0
940	1000	25	AB 6544 A0	—
950	1000	23	—	AB 6546 A9
952.50	1003.30	22.2	AB 6551 E2	—

NOK General Oil Seals

Large-diameter **TB** Type

Nitrile rubber (NBR) oil seal

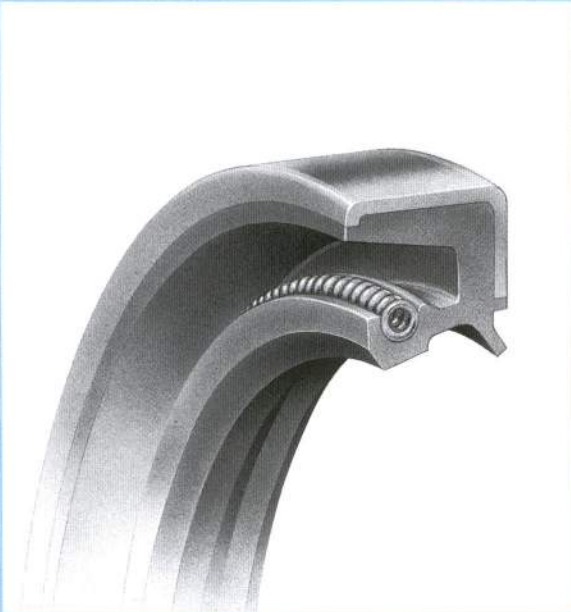

- When ordering, please indicate the NOK part number and the relevant dimensions.
- Check the Guide to Allowable Operating Conditions on pages E-10 and E-11 for relevant information on the seal selected before use.

Lip Material	NOK A941
--------------	----------

Large-diameter TB Type

Material Nitrile (NBR)

● The sectional view on the right shows the typical profile of the seal type.

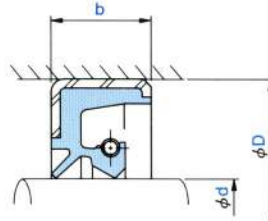

Dimensions			Part Number
Shaft diameter d	Outside diameter D	Width b	
310	370	28	AD 5676 A0
320	360	20	AD 5711 A4
320	380	28	AD 5720 A0
325	365	25	AD 5734 E2
330	370	25	AD 5747 E1
330	390	28	AD 5754 A0
340	400	28	AD 5785 A0
350	410	28	AD 5823 A0
360	400	25	AD 5843 E1
360	420	28	AD 5847 A0
370	415	20	AD 5866 E0
370	430	28	AD 5869 A0
380	440	28	AD 5889 A0
390	440	25	AD 5908 A0
390	450	28	AD 5910 A0
400	460	28	AD 5931 A0
410	470	28	AD 5956 A0
420	480	28	AD 5979 A0
425	475	22	AD 5984 E0
430	470	20	AD 5993 A0
430	480	25	AD 5994 A0
440	500	25	AD 6026 E0
450	500	25	AD 6055 A0
450	510	28	AD 6058 A0
465	510	20	AD 6085 E0
480	540	28	AD 6112 E0
490	550	28	AD 6126 E0
500	560	28	AD 6145 A0
540	600	25	AD 6195 A0
550	610	28	AD 6208 A4
560	620	30	AD 6227 E0
580	640	30	AD 6246 E2
600	650	25	AD 6263 E1
640	690	25	AD 6303 E1
660	740	45	AD 6322 E1
710	770	30	AD 9651 E1
810	870	25	AD 6465 E1
820	900	35	AD 6471 E1



NOK General Oil Seals

MG_{Type}

Nitrile rubber (NBR) oil seal

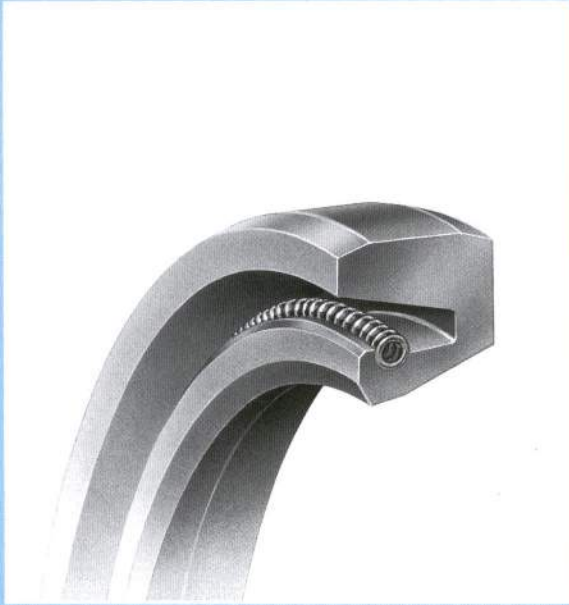

- When ordering, please indicate the NOK part number and the relevant dimensions.
- Check the Guide to Allowable Operating Conditions on pages E-10 and E-11 for relevant information on the seal selected before use.
- Normally, these seals are shipped without any radial cuts. A description for making radial cuts is on page 65.

Lip Material	NOK A103(Press-fit Area A103) NOK A104(Press-fit Area A104)
--------------	--

MG Type

Material Nitrile (NBR)

● The sectional view on the right shows the typical profile of the seal type.

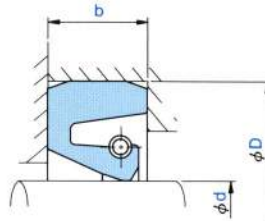

H

Dimensions			Part Number
Shaft diameter d	Outside diameter D	Width b	
17	35	7	AM 0759 E1
19	40	6	AM 0882 A0
20	44	12	AM 1042 A0
22	42	12	AM 1149 A0
25	45	11	AM 1338 A0
25	49	12	AM 1358 E0
25	50	10	AM 1362 E1
28	55	8	AM 1574 E1
30	54	12	AM 1728 A0
32	52	11	AM 1904 A0
35	59	12	AM 2101 E0
35	60	12	AM 2107 A0
36	58	10	AM 2169 A5
38	60	12	AM 2246 E1
40	62	12	AM 2390 E0
40	65	12	AM 2403 A0
40	67	14	AM 2413 E0
42	66	12	AM 2512 A0
45	65	12	AM 2659 E1
45	68	12	AM 2668 E0
45	70	14	AM 2677 E0
45	72	14	AM 2686 E0
45	75	14	AM 2692 A0
50	72	12	AM 2864 G0
50	75	13	AM 2876 E0
50	77	14	AM 2878 E0
50	80	14	AM 2888 A0
55	78	12	AM 3055 E0
55	80	12	AM 3062 E1
55	82	14	AM 3066 E0
55	85	14	AM 3072 A0
58	80	14	AM 3156 A0
60	82	12	AM 3222 A0
60	87	14	AM 3238 E0
60	90	14	AM 3244 F0
65	92	14	AM 3411 G0
65	95	16	AM 3415 A0
70	86	9	AM 3497 E0
70	92	12	AM 3519 E1
70	100	16	AM 3533 A0

Dimensions			Part Number
Shaft diameter d	Outside diameter D	Width b	
75	100	13	AM 3618 E0
75	105	16	AM 3632 A0
80	105	13	AM 3744 E1
80	110	16	AM 3757 A0
85	110	13	AM 3842 E0
85	115	16	AM 3853 A0
90	120	16	AM 3940 A0
95	125	16	AM 4002 A0
100	130	16	AM 4076 A0
100	133	18	AM 4077 E0
100	135	15	AM 4079 F0
105	138	18	AM 4159 E0
105	140	13	AM 4160 A0
105	140	15	AM 4161 E0
105	140	18	AM 4163 E0
110	140	12	AM 4210 E0
110	143	18	AM 4219 E0
110	145	18	AM 4223 A0
115	145	18	AM 4285 A0
115	150	18	AM 4293 E0
120	150	14	AM 4346 E0
120	153	18	AM 4352 E0
120	155	18	AM 4356 A0
125	155	14	AM 4399 E0
125	158	18	AM 4402 E0
125	160	18	AM 4405 A0
130	160	14	AM 4451 E0
130	163	18	AM 4459 F0
130	165	18	AM 4461 A0
135	168	18	AM 4501 E0
135	170	18	AM 4505 A0
140	173	18	AM 4550 F0
140	175	18	AM 4552 A0
140	177	16	AM 4553 E0
145	178	18	AM 4586 E0
145	180	18	AM 4587 A0
150	185	18	AM 4630 A0
150	186	20	AM 4633 E0
155	191	20	AM 4675 A0
160	195	18	AM 4717 A0

MG Type

Material Nitrile (NBR)

● The sectional view on the right shows the typical profile of the seal type.

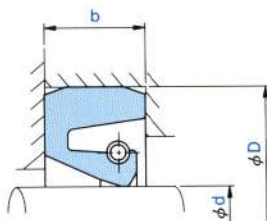

Dimensions			Part Number
Shaft diameter d	Outside diameter D	Width b	
160	196	20	AM 4718 E0
165	201	20	AM 4747 A0
170	206	20	AM 4802 F0
170	210	20	AM 4806 A0
175	211	20	AM 4850 A0
180	216	20	AM 4907 H0
180	220	20	AM 4911 A0
190	230	20	AM 4988 A0
195	231	20	AM 5023 A0
200	230	16	AM 5054 E0
200	239	22	AM 5063 F0
200	240	20	AM 5068 A0
210	249	22	AM 5135 A0
210	265	23	AM 5146 E1
215	254	22	AM 5171 A0
220	260	20	AM 5215 A0
220	260	22	AM 5216 F0
230	269	22	AM 5287 A0
235	275	22	AM 5320 E0
240	280	20	AM 5352 A0
240	295	25	AM 5359 E0
250	290	20	AM 5407 A0
250	295	24	AM 5408 E0
255	300	24	AM 5440 A0
260	305	22	AM 5465 A0
260	310	24	AM 5467 E0
260	315	24	AM 5469 E0
265	315	24	AM 5490 E0
270	320	24	AM 5521 A0
275	320	24	AM 5537 A0
280	325	22	AM 5565 A0
280	325	24	AM 5566 E0
290	335	24	AM 5591 A0
300	345	22	AM 5631 A0
300	350	25	AM 5635 F0
310	355	24	AM 5672 A0
315	360	20	AM 5689 A0
315	365	25	AM 5694 E0
320	370	25	AM 5717 A0
325	375	25	AM 5737 E0

Dimensions			Part Number
Shaft diameter d	Outside diameter D	Width b	
330	380	25	AM 5750 A0
340	390	25	AM 5782 A0
345	390	25	AM 5803 A0
350	400	25	AM 5817 A0
350	400	25.4	AM 5818 A0 ★
355	405	25	AM 5829 A0
360	405	25	AM 5844 A0
370	420	25	AM 5867 A0
380	440	25	AM 5888 A0 ★
390	435	25	AM 5907 E0
390	450	25	AM 5909 A0 ★
400	450	25	AM 5927 A0
410	460	25	AM 5953 A0
410	470	25	AM 5955 A0 ★
420	470	30	AM 5975 A0 ★
430	480	30	AM 5995 A0 ★
440	490	25	AM 6025 A0
450	500	25	AM 6055 A0
455	510	28	AM 6063 E0 ★
460	515	28	AM 6078 A0 ★
470	525	30	AM 6095 A0 ★
475	525	25	AM 6104 A0
480	530	30	AM 6108 A0 ★
480	540	25	AM 6111 A0 ★
495	545	30	AM 9129 E1 ★
500	550	20	AM 6142 A0
500	560	25	AM 6144 A0 ★
520	570	24	AM 6169 A0
540	590	30	AM 6194 A0 ★
550	600	25	AM 6205 E1
560	610	30	AM 6224 F1 ★
570	630	30	AM 9040 A0 ★
580	630	25	AM 6243 A0
600	650	30	AM 6264 A0 ★
600	670	30	AM 6270 A0 ★
610	660	30	AM 6280 A0 ★
620	670	28	AM 6285 A0 ★
635	705	30	AM 6302 A5 ★
640	702	29	AM 6304 A5 ★
650	705	20	AM 6312 A0 ★

★: Lip material is NOK A104

WT Type, WTT Type

Nitrile rubber (NBR) oil seal

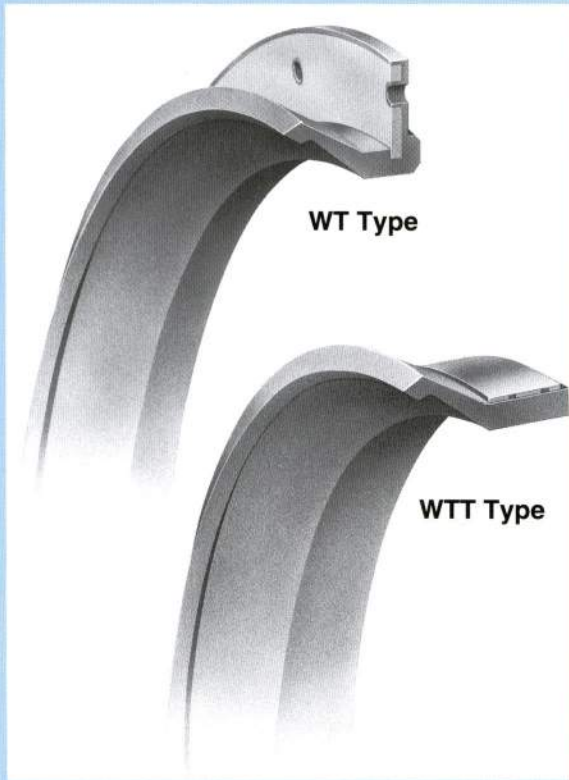

■ Handling of WTT Type

- The WTT Type oil seal is secured with a tightening collar band at its cut point. Any mounting diameter can be selected.
- The maximum mounting diameter is 1500 mm, and seven mounting lengths are available (35, 40, 45, 50, 55, 70, 75 mm). (For your reference, the product sizes currently available are shown on page H-94.)
- The WTT Type oil seal cannot completely prevent the entry of rolling fluid or cooling water. Provide a drain at the bottom.
- Position the bolt for the collar band at a 45-degree angle from the drain.

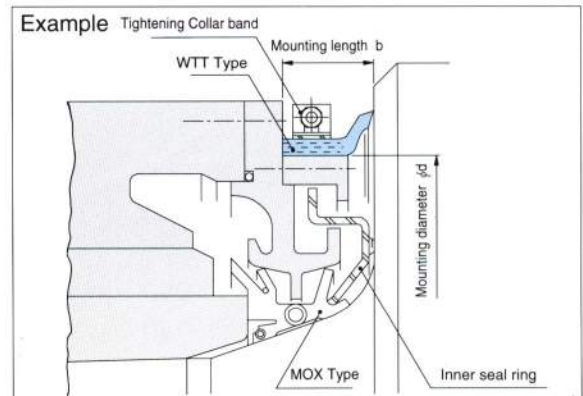

The WT Type oil seal cannot completely prevent the entry of rolling fluid or cooling water. Provide a drain at the base.

- When ordering, please indicate the NOK part number and the relevant dimensions.
- Check the Guide to Allowable Operating Conditions on pages E-10 and E-11 for relevant information on the seal selected before use.

Lip Material	NOK A103
--------------	----------

WT Type

Material Nitrile (NBR)

● The sectional view on the right shows the typical profile of the seal type.

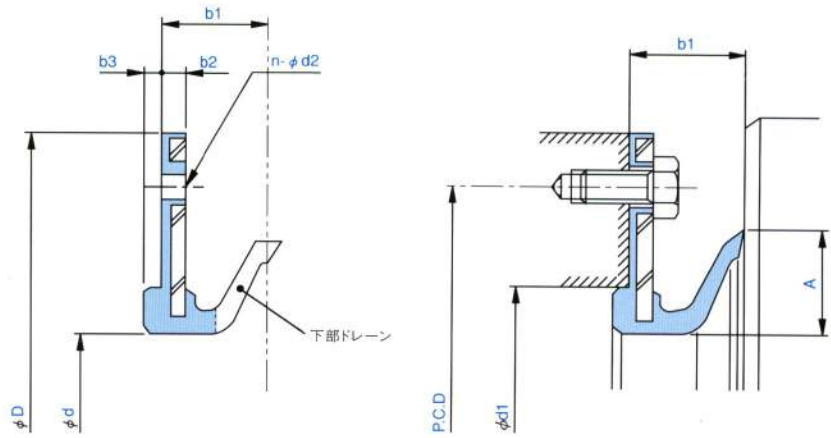

※ Consult us for the positional relationship between the bolt hole and drain.

Inside diameter d	Outside diameter D	Dimensions					Part Number	Mounting bolt pattern diameter		
		b ₁	b ₂	b ₃	n (Number of places)	d ₂		P.C.D	φd ₁	A
190	244	19	5	0	8	8	AZ 4992 E0	225	—	18
227	280	35	5	0	8	9	AZ 9301 E0	260	—	18
320	380	30	8	0	6	9.5	AZ 9375 E1	355	—	19
325	385	30	8	0	6	9.5	BZ 8039 E0	360	—	20
330	400	35	5	0	8	9.5	AZ 9497 E4	380	—	22
340	435	30	5	0	8	9	AZ 9378 E1	415	—	32
350	414	35	5	0	8	10	AZ 9091 F0	395	—	22
380	455	35	8	0	8	12	AZ 9594 E0	430	—	22
420	480	26	5	0	8	10	AZ 9401 E0	462	—	18
430	490	26	8	0	12	10	AZ 5999 E0	472	—	20
435	489	25.4	5	0	8	10	AZ 6011 E0	470	—	21
440	510	26	8	0	12	9	AZ 6030 E0	490	—	18
440	514	35	5	0	8	12	AZ 6031 F0	490	—	22
440	530	50	10	0	8	14	AZ 6033 E0	500	—	36
458	540	26	8	0	12	11.5	AZ 6071 E0	510	—	19
580	650	51	10	0	12	12	BZ 8338 E0	626	—	40
650	760	45	12	0	12	12	AZ 6317 E0	730	—	39
680	778	45	12	0	12	14	AZ 9043 E0	740	—	25
705	830	76.2	11	0	8	18	AZ 6362 E0	790	—	65
710	810	46	10	0	8	14	AZ 6373 E0	767	—	27
740	840	56.2	10	0	16	18	AZ 6400 E0	805	—	43
760	842	35	8	0	12	11	AZ 9698 E0	812	—	24
760	898	40	10	0	10	12	AZ 6424 E0	866	—	38
870	975	40	10	0	12	15	AZ 9608 E0	940	—	27
932	1042	24	5	3	6	12	BZ 9506 E0	1015	970	23
962	1035	46.8	6	3	24	12	BZ 8919 E0	1010	983	44
1000	1108	38	10	0	12	14	AZ 6579 E0	1065	—	33
1052	1134	37	9	5	24	12	BZ 9839 E0	1115	1078	42
1120	1230	25	5	5	16	10	AZ 9704 E2	1200	1169	27
1148	1240	40	5	5	22	14	BZ 9826 E0	1215	1180	49
1310	1400	50	9	5	24	14	AZ 9737 E0	1370	1344	39
1704	1795	62	12	5	18	11	AZ 9087 E0	1770	1725	37

WTT Type

Material Nitrile (NBR)

● The sectional view on the right shows the typical profile of the seal type.

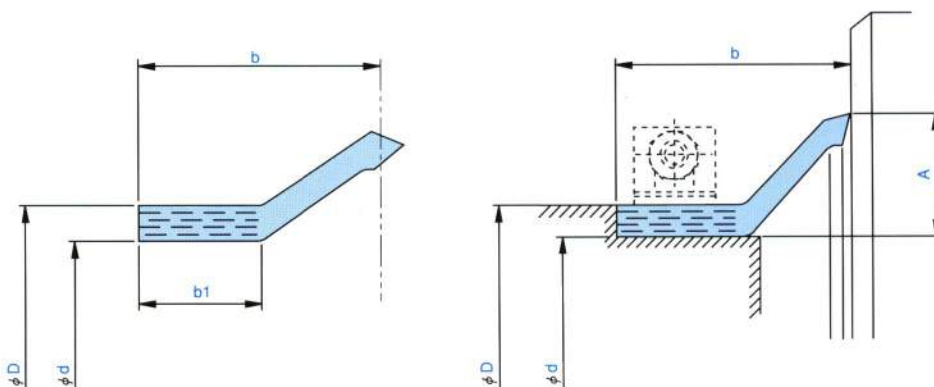

Dimensions					Part Number
Inside diameter d	Outside diameter D	Width		A	
		b	b ₁		
400	416	35	21	26	BZ 8075 E0
440	456	35	21	26	AZ 6019 E0
450	466	35	21	26	BZ 8083 E0
450	466	40	26	24	BZ 8347 E0
460	476	40	26	24	BZ 8348 E0
520	536	35	21	26	AZ 9029 E0
535	551	35	21	26	AZ 9291 E1
545	561	35	21	26	AZ 9567 E1
546	562	35	21	26	BZ 8383 E0
550	566	35	21	26	BZ 8349 E0
590	606	50	36	24	AZ 9527 E0
595	611	35	21	26	AZ 6260 E0
600	616	40	26	24	BZ 8372 E0
605	621	35	21	26	BZ 8352 E0
625	641	35	21	26	AZ 6290 E0
655	671	40	26	24	BZ 8317 E0
700	716	45	31	24	AZ 9064 E0
715	731	40	26	24	AZ 6382 E0
720	736	35	21	26	AZ 9646 E0
770	786	50	36	24	AZ 6433 E0
780	796	45	31	24	AZ 9665 E1
790	806	70	56	24	AZ 9678 E0
800	816	40	26	24	BZ 9206 E0
835	856	75	40	40	AZ 9693 E0
850	866	45	31	24	AZ 9622 E0
875	891	40	26	24	AZ 6511 E0
900	916	50	36	24	AZ 9041 E0
940	956	50	36	24	AZ 6543 E0
962	978	35	21	26	AZ 9619 E0
990	1006	40	26	24	AZ 6570 E1
1020	1036	40	26	24	AZ 9794 E0
1030	1046	35	21	26	BZ 9818 E0
1060	1076	40	26	24	AZ 6601 E0
1070	1086	50	26	24	AZ 9733 E0
1090	1106	45	31	24	AZ 6615 E0

Dimensions					Part Number
Inside diameter d	Outside diameter D	Width		A	
		b	b ₁		
1100	1116	45	31	24	AZ 9785 E0
1120	1136	45	31	24	AZ 6627 E0
1145	1161	55	41	24	AZ 6635 E0
1165	1181	50	36	24	AZ 6639 E0
1180	1196	50	36	24	AZ 6642 E0
1210	1226	50	36	24	AZ 6649 E0
1294	1315	75	40	40	BZ 9803 E0
1524	1545	75	40	40	AZ 6683 E0

NOK General Oil Seals

OKC3 Type

Nitrile rubber (NBR) oil seal

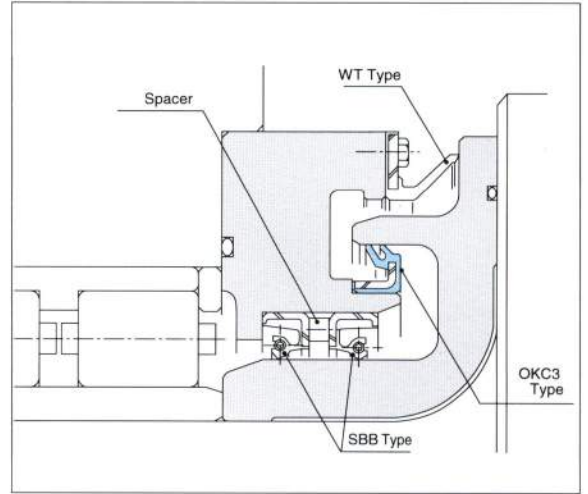

- When ordering, please indicate the NOK part number and the relevant dimensions.
- Check the Guide to Allowable Operating Conditions on pages E-10 and E-11 for relevant information on the seal selected before use.

Lip Material	NOK A103
--------------	----------

OKC3 Type

Material Nitrile (NBR)

● The sectional view on the right shows the typical profile of the seal type.

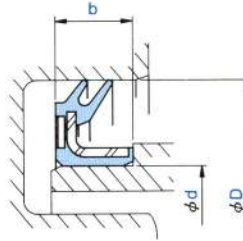

Dimensions			Part Number
Shaft diameter d	Outside diameter D	Width b	
274	304	15	A0 9325 E0
360	400	20	A0 5842 E0
400	440	20	A0 5923 E0
420	470	20	A0 5971 E0
420	470	25	A0 5973 E0
440	480	20	A0 6022 E0
465	505	25	A0 6084 E0
485	525	25	A0 6120 E0
490	530	20	A0 9499 E0
540	580	25	A0 9546 E1
560	600	25	A0 6220 E1
580	624	25	A0 6242 E2
610	660	25	A0 6279 F0
640	685	18	A0 9517 E0
650	700	25	A0 6310 E0
680	720	25	A0 9574 E0
710	750	20	A0 6364 E2
710	760	25	A0 6366 E0
720	770	25	A0 6385 E1
740	780	30	A0 9616 E0
750	800	25	A0 6407 E0
770	810	29	A0 6435 E0
780	820	18	A0 6445 E0
790	840	25	A0 6451 E0
800	840	20	A0 9090 E0
820	870	25	A0 9631 E0
850	900	30	A0 6489 E0
880	930	25	B0 9220 E0
900	950	25	A0 6527 E1
930	980	25	A0 9612 E0
940	990	25	B0 9512 E0
980	1030	25	A0 6566 E0
1000	1040	28	A0 9075 E0
1040	1090	25	A0 6596 E0
1080	1130	25	A0 6613 E0
1090	1150	25	A0 6616 E0
1110	1160	25	A0 9708 E1
1200	1250	30	A0 9280 E1
1204	1254	25	A0 9755 E0
1530	1590	30	A0 9791 E0

NOK General Oil Seals

MO Type (Mogoil seal)

Nitrile rubber (NBR) oil seal

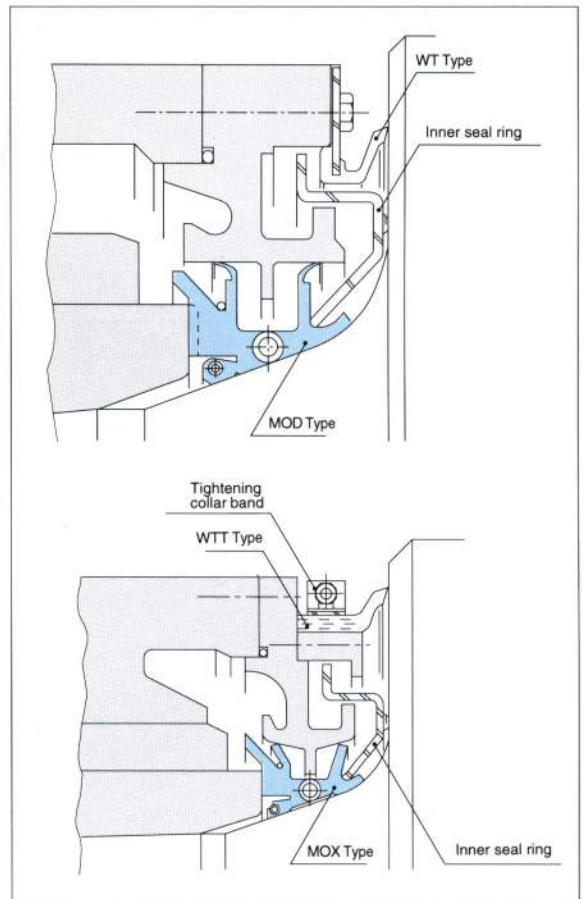
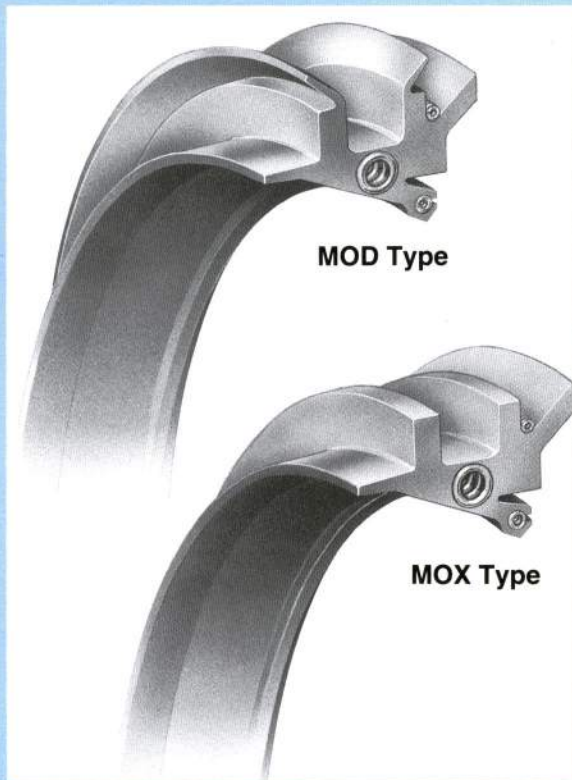

- When ordering, please indicate the NOK part number and the relevant dimensions.
- Check the Guide to Allowable Operating Conditions on pages E-10 and E-11 for relevant information on the seal selected before use.

Lip Material	NOK A989
--------------	----------

MO Type

Material Nitrile (NBR)

● The sectional view on the right shows the typical profile of the seal type.

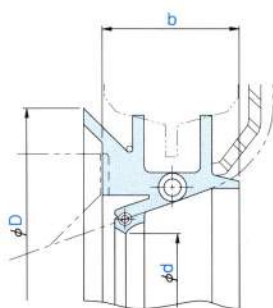

MOX Type

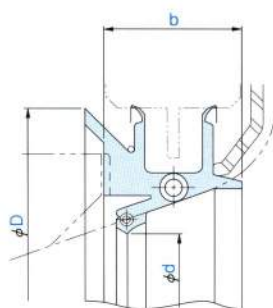

MOD Type

Dimensions			Part Number	Part Number	Bearing size
Shaft diameter d	Outside diameter D	Width b			
140	180	35	AN 4556 E1	—	8 1/4" -72
165	214	40	AN 4750 E1	—	10" -72
201	261	41	AN 5091 E1	—	12" -72
236	294	46	AN 5330 E1	—	14" -72
272	341	50	AN 5528 E1	—	16" -90
310	388	48	AN 5679 E2	—	18" -90
367	444	50	AN 5857 E1	—	21" -90
415	540	73	AN 9044 E1	—	24" -90
524	650	83	AN 6178 E1	—	30" -90
670	794	84	AN 9597 E0	—	38" -84
706	826	83	AN 6363 E1	—	40" -90
745	900	93	AN 6403 F1	—	42" -90
750	900	110	AN 6414 E0	—	42" -90
780	935	93	AN 6448 E1	—	44" -90
818	965	93	AN 9046 E1	—	46" -90
860	1010	93	AN 6502 E1	—	48" -90
895	1044	93	AN 6523 E1	—	50" -72
896	1048	89	—	BN 9210 H0	50" -75
925	1075	93	AN 9047 E1	—	52" -72
960	1116	93	AN 6556 E1	—	54" -72
960	1118	93	—	BN 9806 H0	54" -72
995	1160	95	AN 6573 E1	—	56" -90
1025	1160	93	AN 6591 E0	—	56" -81
1025	1174	88	—	BN 9815 H0	56" -75
1052	1232	93	AN 9748 E0	—	60" -72
1175	1320	93	AN 6641 E2	—	64" -72
1250	1400	100	AN 9048 E1	—	68" -81
1300	1470	108	AN 9051 E1	—	70" -80
1440	1610	108	AN 9728 E0	—	76" -72
1590	1760	108	AN 9731 E0	—	82" -72

NOK General Oil Seals

MOY Type (Meseta seal)

Nitrile rubber (NBR) and hydrogenated nitrile rubber (HNBR) oil seal

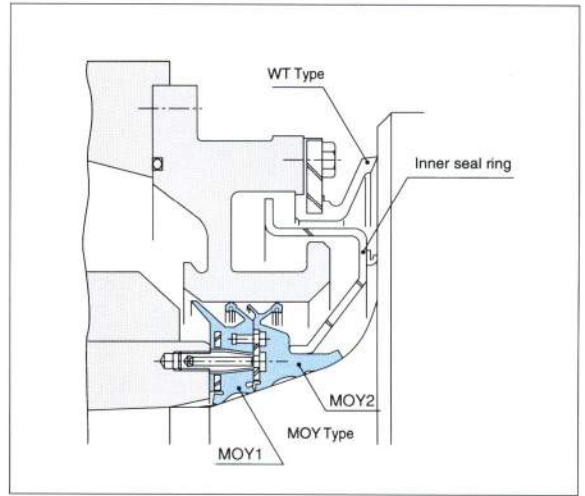
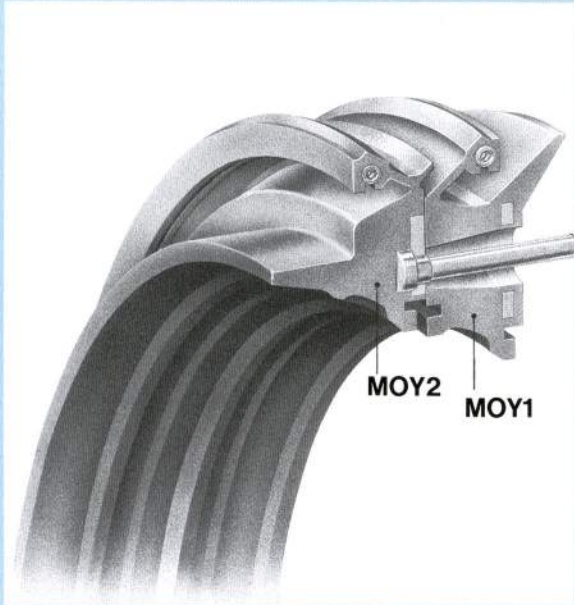

- When ordering, please indicate the NOK part number and the relevant dimensions.
- Check the Guide to Allowable Operating Conditions on pages E-10 and E-11 for relevant information on the seal selected before use.

Lip Material	NOK G418(Seal ID mounting area A989)
--------------	--------------------------------------

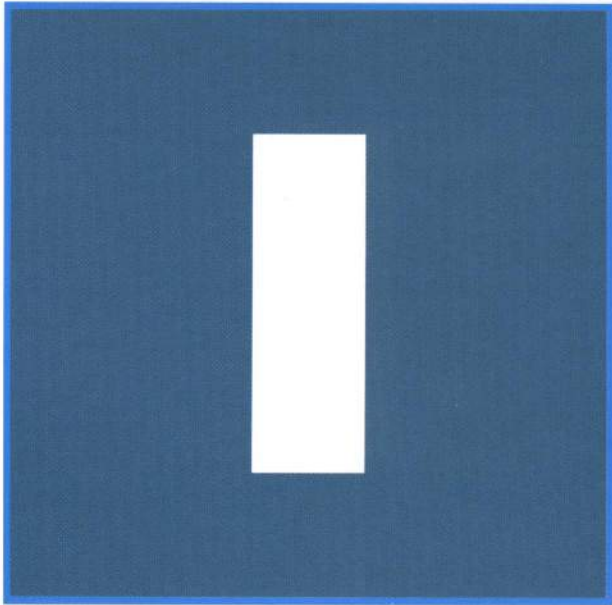

Leakage Troubleshooting Guide

- Troubleshooting Guide ————— I-2
- 1. Causes of Seal Leakage ————— I-2
- 2. Misdiagnosis Examples ————— I-8

I. SEAL LEAKAGE TROUBLESHOOTING GUIDE

Causes of Seal Leaks

If oil leakage is discovered, first determine the point of origin of the leak. The leaks may not have originated from the oil seal, and residual oil or grease on the seal itself can also be mistaken for a leak.

Seal leaks are divided into two groups: leaks from the sealing lip and leaks from the press-fit area of the housing, as illustrated in Fig. 1. Typical causes of each group of leaks are shown in factorial diagrams (Figs. 2 and 3). Examples of improper diagnosis is discussed on page I-8.

Figure 1: The Two Points of Origin of Seal Leakage

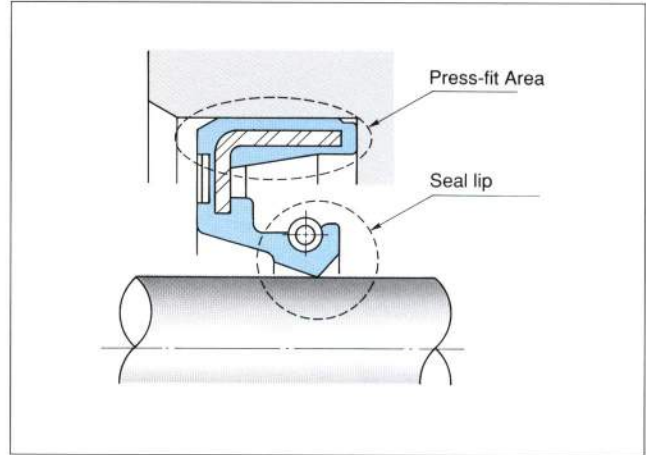

Figure 2: Lip Leakage Diagnosis

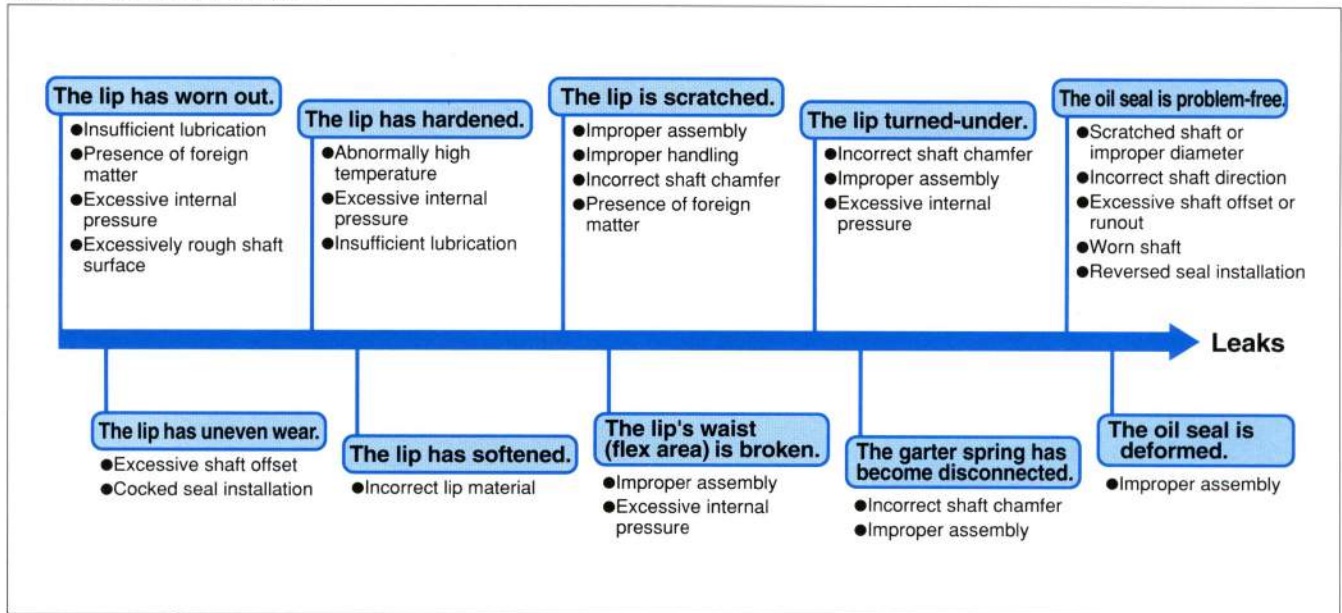
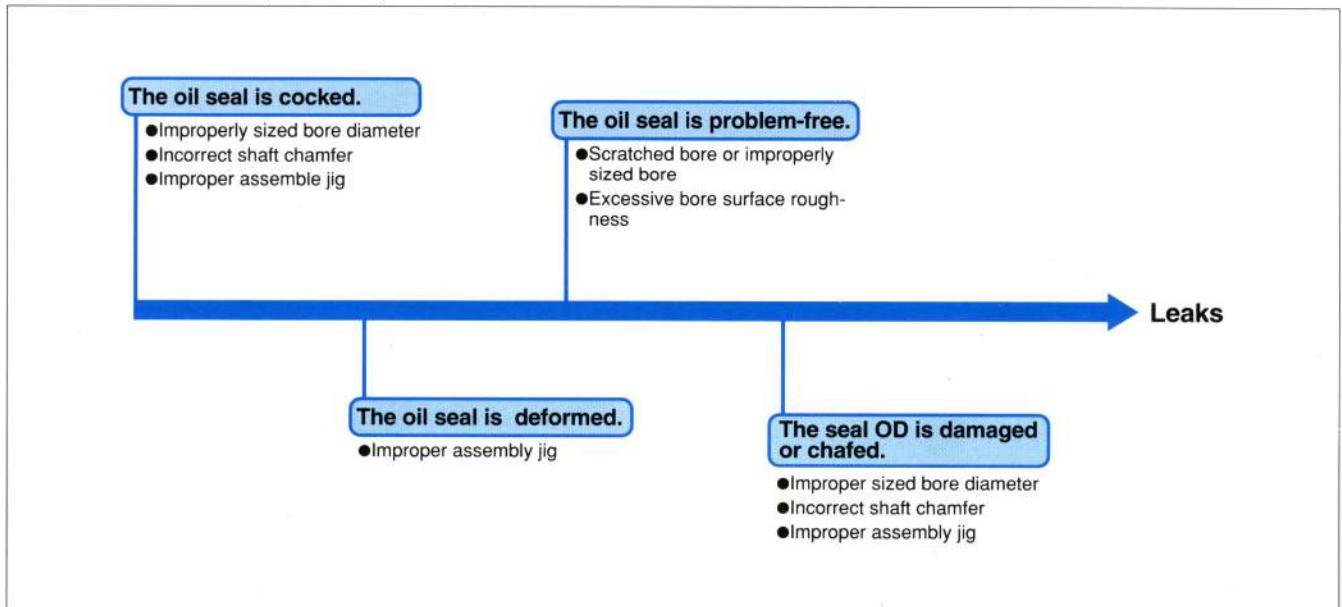
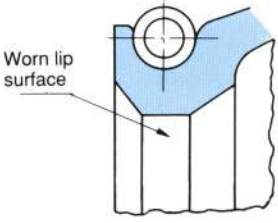
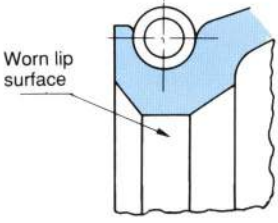
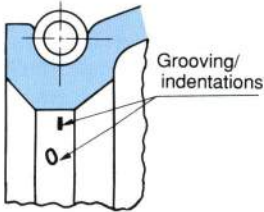
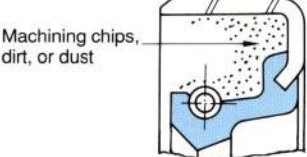
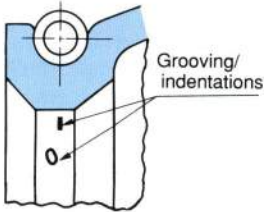
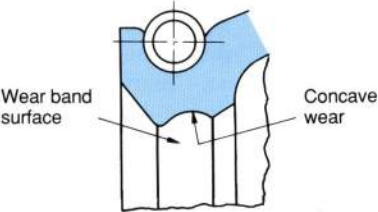

Figure 3: Press-Fit Area (OD) Leakage Diagnosis





Leakage from the Seal Lip

Table 1: Leakage from the Seal Lip

Factor	Failure mode	Cause	Solution
Insufficient lubrication	<p>The lip edge is severely worn, and the worn surface is dull and rough.</p> 	<ul style="list-style-type: none"> ● Abnormally high wear has occurred from the friction of insufficient lubrication. The amount of lubricant was below the specified level, and therefore did not reach the sealing lip. 	<ul style="list-style-type: none"> ● Add lubricant up to the specified level and operate.
		<ul style="list-style-type: none"> ● The machine design did not allow adequate oil flow to the seal lip. Examples: <ul style="list-style-type: none"> ● There is a slinger in front of the sealing lip. ● There is a drain in front of the sealing lip. ● If a spray/mist lubrication method is used, the lube did not reach the seal until several minutes after start-up. 	<ul style="list-style-type: none"> ● As a quick solution, change to a double-lip seal model, and apply grease between the lips. ● As a permanent solution, change the structure near the oil seal to allow lubricant to freely flow to the seal lip area.
Excessive lip wear	<p>The lip edge is severely worn, and there are grooves or indentations the worn surface.</p> 	<ul style="list-style-type: none"> ● Since a shaft or seal contaminated with cutting chips was used, the contaminants were embedded in the sealing lip.  <ul style="list-style-type: none"> ● Since the oil seal was assembled in the presence of dirt or dust, the contaminants became embedded in the sealing lip. ● Since the seal or housing was assembled with liquid gasket sealant, the sealant contaminated the shaft or seal. ● Since a seal or shaft with paint stains was used, the paint contaminated the shaft/seal. 	<ul style="list-style-type: none"> ● During assembly, use particular care to ensure that the oil seal or shaft is not contaminated with dirt or sand. ● Clean the machine with the same lubricant sealed in the machine.
		<ul style="list-style-type: none"> ● Since the oil seal was assembled in the presence of dirt or dust, the contaminants became embedded in the sealing lip. ● Since the seal or housing was assembled with liquid gasket sealant, the sealant contaminated the shaft or seal. ● Since a seal or shaft with paint stains was used, the paint contaminated the shaft/seal. 	<ul style="list-style-type: none"> ● During assembly, use particular care to ensure that the oil seal or shaft is not contaminated with dirt or sand. ● Clean the machine with the same lubricant sealed in the machine.
Excessive internal pressure	<p>The lip edge is severely worn, and the wear band is concave.</p> 	<ul style="list-style-type: none"> ● Pressure at the oil seal area exceeded the design pressure. 	<ul style="list-style-type: none"> ● Change to a high-pressure type oil seal. ● Provide a vent breather to maintain proper pressure.
Excessive shaft surface roughness	<p>The lip edge is severely worn, and there are circumferential grooves on the wear band.</p>	<ul style="list-style-type: none"> ● The seal lip has severe wear since the shaft finish was rougher than the specified range of 0.8 to 2.5 mm Rmax. 	<ul style="list-style-type: none"> ● Smooth the shaft surface to 0.8 to 2.5mm Rmax with emery paper (#240 or similar). Do not oscillate the emery paper axially along the shaft. ● Replace the shaft with one having the specified finish roughness.

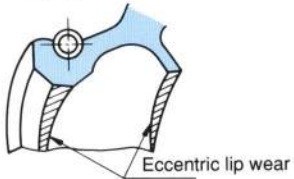
Leakage from the Seal Lip

Factor		Failure mode	Cause	Solution
Eccentric lip wear	Large shaft-to-bore offset	<p>The lip wear band width is uneven around the circumference, and the minimum and maximum wear locations correspond well on the main lip and the secondary lip.</p> 	<ul style="list-style-type: none"> ● Machine has high shaft-to-bore misalignment 	<ul style="list-style-type: none"> ● Improve the concentricity of the shaft and housing.
			<ul style="list-style-type: none"> ● Shaft has high dynamic runout 	<ul style="list-style-type: none"> ● Improve the shaft runout.
	Cocked seal installation	<p>The lip wear band is uneven around the circumference, and the minimum and the maximum wear locations of the main and secondary lips are inversely related.</p> 	<ul style="list-style-type: none"> ● The oil seal was installed cocked because the housing bore diameter is too small. 	<ul style="list-style-type: none"> ● Use a housing within the design dimensions.
			<ul style="list-style-type: none"> ● The oil seal was installed cocked due to an unchamfered or incorrectly chamfered housing. ● The oil seal was installed cocked because the assembly jig was cocked. 	<ul style="list-style-type: none"> ● Correctly chamfer the housing. (Refer to Chapter F.) ● Improve the assembly jig. (Refer to Chapter G.)
Lip hardening	Abnormally high temperature	<p>The lip wear band is smooth and glossy. The entire sealing lip is hardened and there are cracks.</p> 	<ul style="list-style-type: none"> ● The oil temperature near the sealing lip exceeded the heat-resistance limits of the rubber. ● The oil temperature exceeded the design temperature limits due to changes in the application conditions. 	<ul style="list-style-type: none"> ● Investigate the cause and take appropriate measures to prevent future temperature rises. ● Replace with a seal with a better heat-resistant lip material. Example: Change from nitrile rubber (NBR) to acrylic rubber (ACM). Change from acrylic rubber (ACM) to fluorocarbon rubber (FKM). Note that a change of lip material also changes the oil resistance.
	Excessive internal pressure	<p>The lip wear band is wide and glossy. There are cracks on the sliding lip.</p>	<ul style="list-style-type: none"> ● The application pressure exceeded the limits of the oil seal. 	<ul style="list-style-type: none"> ● Change to a high-pressure type oil seal. ● Provide a vent to relieve pressure.
	Insufficient lubrication	<p>The lip wear band is smooth and glossy, and there are cracks on the lip sliding surface. Hardening usually occurs only on the wear surface.</p>	<ul style="list-style-type: none"> ● A dry-wear condition occurred because the machine had an insufficient lubricant level. ● A dry-wear condition occurred because the machine's mist-type oil supply is inadequate. 	<ul style="list-style-type: none"> ● Add lubricant up to the specified level and operate. ● As a quick solution, change to a double-lip seal model, and apply grease between the lips. ● As a permanent solution, change the structure near the oil seal to allow oil to flow freely up to the seal lip.
Lips softening	Inappropriate lip material	<p>The seal lip is swollen and soft.</p>	<ul style="list-style-type: none"> ● The seal lip has become swollen because the wrong lip material was selected. 	<ul style="list-style-type: none"> ● Change to an oil seal featuring a lip material that does not swell up in the presence of the lubricant used.
			<ul style="list-style-type: none"> ● The seal lip swelled because it was soaked in solvents or gasoline, or was not wiped off after washing. 	<ul style="list-style-type: none"> ● Do not wash the oil seal in solvents.

Leakage from the Seal Lip

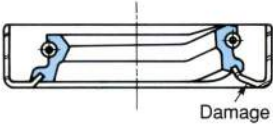

Factor	Failure mode	Cause	Solution	
Scratches on the lip	Improper assembly	There are visible scratches on the sealing edge.	<ul style="list-style-type: none"> ●The seal lip was scratched through contact with shaft keyways or splines. ●Cap the keyways or splines to prevent scratching. 	
		Improper handling	There are visible scratches on the sealing edge.	<ul style="list-style-type: none"> ●The seal lip was scratched because it was assembled over burrs or other defects in the shaft chamfer. ●Remove burrs and defects.
			There are visible scratches on the sealing edge.	<ul style="list-style-type: none"> ●The seal lip was scratched because the lip came into contact with sharp metal parts during transit or storage. ●Improve the transit/storage method.
			There are visible scratches on the sealing edge.	<ul style="list-style-type: none"> ●The seal lip was scratched because the oil seal was handled with gloves contaminated with machine cutting chips. ●Avoid touching the seal lip edge.
	Improper shaft chamfer	There are visible scratches on the sealing edge.	<ul style="list-style-type: none"> ●The lip was caught at the shaft end and scratched because the shaft was incorrectly chamfered. ●Chamfer the shaft correctly. (Refer to Chapter F.) 	
Lip turn-under	Contamination on the seal	<ul style="list-style-type: none"> ●There is contamination on the seal lip edge. ●There are indentations on the lip sliding area. 	<ul style="list-style-type: none"> ●A shaft contaminated with cutting chips was used, and the chips became lodged in the lip ●Since parts contaminated with metal shavings were used, the shavings became lodged in the lip edge. ●Since a dusty or dirty shaft or oil seal was used, foreign matter caught in the lip edge. ●Wash the machine parts thoroughly prior to assembly. 	
		Improper shaft chamfer	Part of the lip is folded under and pinched to the shaft.	<ul style="list-style-type: none"> ●The lip was caught on the shaft end and folded under due to a poor shaft chamfer. ●Chamfer the shaft to the correct size, and apply grease to the chamfered area before assembly.
	Improper assembly		Part of the lip is folded under and pinched to the shaft.	<ul style="list-style-type: none"> ●The lip folded under due to improper shaft and housing assembly. ●Assemble the unit carefully by aligning the shaft and housing bore. Apply grease to the shaft end.
Broken waist (flex section) of the lip	Excessive internal pressure	Part or all of the lip folded under.	<ul style="list-style-type: none"> ●Abnormally high pressure occurred during operation, blowing out the lip. ●Change to a pressure-free structure. ●Use pressure-resistant oil seals. 	
		Improper assembly	There are cracks on the hinge flex area of the lip.	<ul style="list-style-type: none"> ●The lip hinge flex section cracked because the lip was squeezed out of shape during assembly. ●Assemble the unit carefully by aligning the shaft and housing bore.
			High internal pressure	There are cracks on the hinge flex area of the lip.
There are cracks on the hinge flex area of the lip.	<ul style="list-style-type: none"> ●The lip hinge flex section cracked due to pressures exceeding the design limits. ●Change to a structure that does not produce excessive pressure. ●Change to a pressure-resistant oil seal. 			

Leakage from the Seal Lip

Factor	Failure mode	Cause	Solution	
Garter spring disconnected	Garter spring disconnected	<ul style="list-style-type: none"> ●The lip caught on an improperly chamfered shaft end, and popped the garter spring. 	<ul style="list-style-type: none"> ●Properly chamfer the shaft and apply grease to the chamfered area before assembly. 	
		<ul style="list-style-type: none"> ●The garter spring was disconnected because of improper shaft and housing assembly 	<ul style="list-style-type: none"> ●Assemble the unit carefully by aligning the shaft and housing bore. Apply grease to the shaft chamfer. 	
Oil seal deformation	<p>Seal is damaged causing lip deformation.</p> 	<ul style="list-style-type: none"> ●The oil seal was deformed due to an inappropriate assembly jig. 	<ul style="list-style-type: none"> ●Improve the assembly jig. 	
The oil seal is problem-free:	Scratches or porosity on shaft	—	<ul style="list-style-type: none"> ●There were visible scratches or porosity in the shaft's contact area. 	<ul style="list-style-type: none"> ●Place a shim behind the oil seal to displace the lip contact area to a virgin shaft finish location. ●Remove scratches or porosity and refinish.
	Shaft has machine lead on its surface	—	<ul style="list-style-type: none"> ●Shaft was finished by lathe cutting only. 	<ul style="list-style-type: none"> ●Smooth out the shaft sliding area using emery paper (#240 or similar) without axial movement.
		—	<ul style="list-style-type: none"> ●The grinder or emery paper moved axially during the finish operation 	<ul style="list-style-type: none"> ●Change the machining method (finish without axial feed, plunge direction only).
	Shaft eccentricity	—	<ul style="list-style-type: none"> ●A worn bearing allowed shaft runout to exceed the design limits. 	<ul style="list-style-type: none"> ●Change the bearing.
		—	<ul style="list-style-type: none"> ●A general-purpose oil seal was used for a structurally large shaft runout. 	<ul style="list-style-type: none"> ●Change to an oil seal that resists eccentricity.
Shaft wear	—	<ul style="list-style-type: none"> ●The oil seal was installed with dirt or metal shaving contamination. ●The lubricant was degraded or contaminated with dirt or other foreign matter. ●Contaminants entered into the lip contact area. 	<ul style="list-style-type: none"> ●Wash the machine components thoroughly, then place a shim behind the oil seal to displace the lip contact to a new area on the shaft. ●For a small amount of dust, change to an oil seal with a dust lip or dust cover. 	
	—	<ul style="list-style-type: none"> ●A non-ferrous metal shaft was used. 	<ul style="list-style-type: none"> ●Use an appropriate shaft material and hardness. 	
Reversed installation orientation	—	<ul style="list-style-type: none"> ●The oil seal was installed incorrectly during assembly. 	<ul style="list-style-type: none"> ●Insert the oil seal with its seal lip directed towards the fluid side. 	

Leakage from the Press-Fit Area (Seal OD)

Table 2: Leakage from the Press-Fit Area (Seal OD)

Factor	Failure mode	Cause	Solution
Cocked seal installation	Before removing the oil seal: ●The oil seal is cocked with respect to the housing and shaft. After oil seal is removed: ●Contact at the press-fit is not even.	●The oil seal was cocked because the housing bore diameter was undersized.	●Finish the housing bore to the proper ID.
		●The oil seal was cocked due to an unchamfered or improperly chamfered housing.	●Chamfer the housing bore. (Refer to Chapter F.)
		●The oil seal was cocked because the assembly jig was cocked.	●Improve the assembly jig. (Refer to Chapter G.)
Seal deformation	●The fit trace is disconnected locally. <div style="text-align: center;">  </div>	●The oil seal was deformed because of an improperly designed assembly jig.	●Improve the assembly jig.
		●A gap in the press-fit occurred due to seal deformation from rough handling.	●Handle the seal carefully.
Scrapes or gouges on the OD	After the oil seal is removed: ●There are longitudinal scratches on the oil seal press-fit. The rubber was gouged.	●The oil seal was cocked because the housing bore diameter was undersized.	●Finish the housing bore to the proper ID.
		●Scratching occurred at the OD of the oil seal due to an unchamfered or improperly chamfered housing.	●Chamfer the housing bore. (Refer to Chapter F.)
		●The OD of the seal was gouged due to misalignment of the assembly jig with the housing.	●Properly align the jig with the housing.
The oil seal is problem-free.		●The housing bore ID surface was scratched because the seal was inserted with metal shavings or other foreign matter caught between the seal and the bore. ●The bore ID surface is scratched due to repeated seal removal and installation. ●There was large porosity on the bore ID.	●Apply a thin coat of liquid gasket sealant so that the scratches and porosity on the bore ID hole are filled. Use care not to contaminate the seal lip or the shaft with the sealant.
		●The housing bore ID surface was scratched due to seal installation with burrs on the bore chamfer.	●Remove the seal and check for grooving on the chamfered area of the housing bore. Remove these grooves and apply liquid gasket sealant to the bore ID surface.
		●The bore ID surface is too rough.	●Quick solution: Apply liquid gasket sealant to the housing bore ID. ●Permanent solution: Finish the bore ID surface to the correct roughness. (See pages F-8 to F-13.)

■ Examples of Leak Misdiagnosis

- ❶ Leaks from the mating surfaces of the machine
 - The gasket is deformed.
 - The mounting bolts are loose.
 - There are defects in the mating parts (i.e., indentations, burrs).
- ❷ Leaks caused by scratches or porosity in the housing, or other machine covers
- ❸ Residual oil or grease from assembly on the air side of the oil seal
- ❹ Extrusion of pre-lube grease or oil from initial assembly

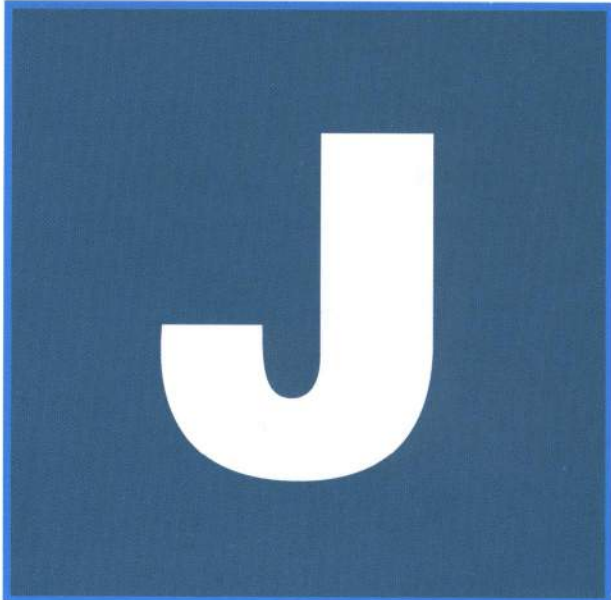

Technical Data

- Frictional Torque of an Oil Seal ————— J-2
- Service Life of a Seal ————— J-5
- Oil & Chemical Resistance Ratings
of NOK's Lip Materials ————— J-6



Frictional Torque of an Oil Seal

The frictional torque of an oil seal can be expressed by equation (1).

$$T = f \cdot Pr \cdot r \quad \dots\dots\dots (1)$$

T = frictional torque (N·cm{kgf·cm})
 f = coefficient of friction
 Pr = radial lip load onto shaft (N{kgf})
 r = radius of shaft (cm)

The coefficient of friction (f) is determined by many factors, but it generally means dynamic friction under lubricated conditions, and can be expressed by equation (2).

$$f = \Phi (\mu \cdot u \cdot b / Pr)^{1/3} \quad \dots\dots\dots (2)$$

Φ = constant determined by the state of the oil film
 μ = viscosity of sealing fluid (N·s/cm²{kgf·s/cm²})
 u = linear shaft speed (cm/s)
 b = lip-to-shaft contact width (cm)

It becomes evident that the coefficient of friction (f) for a specific oil seal is influenced by the viscosity (μ) of the sealing fluid and the linear shaft speed (u).

Figure 1 shows the relationship between frictional torque and oil temperature by oil type. Frictional torque decreases as the oil's viscosity decreases. Also, frictional torque is inversely related to the oil temperature, since oil becomes less viscous as oil temperature increases.

Figure 1: Frictional Torque vs Oil Temperature for Several Oils

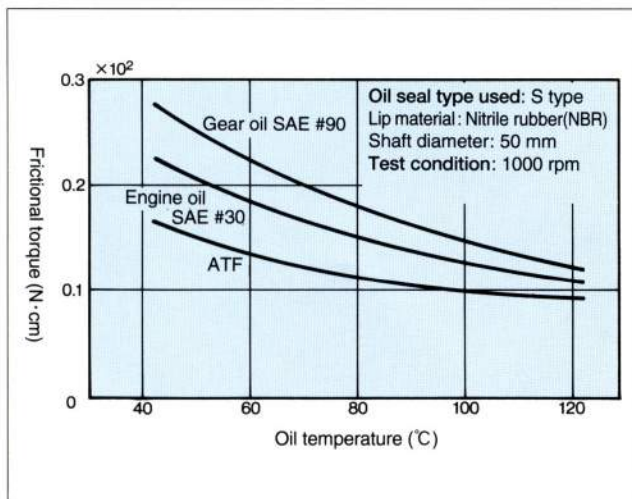

The linear shaft speed also influences frictional torque. **Figures 2 and 3** show the relationship between shaft speed and frictional torque.

Figure 2 shows a case in which the oil temperature is constant. Frictional torque increases as shaft speed increases.

Figure 2: Frictional Torque vs Shaft Speed (with constant oil temperature)

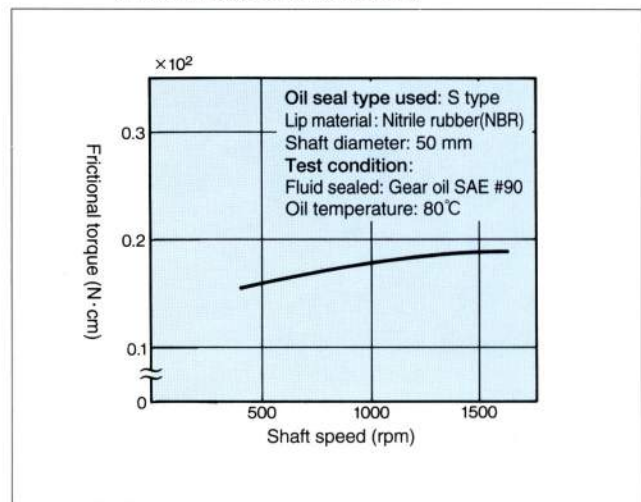
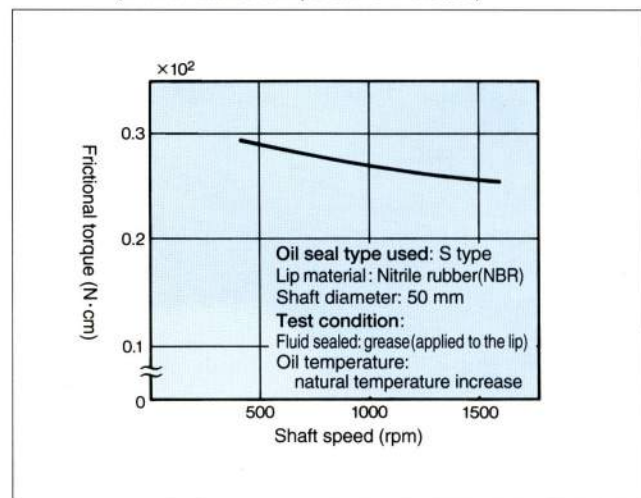

Figure 3 shows a case in which the grease temperature is not controlled (heated naturally via friction). Frictional torque decreases as shaft speed increases. This is because as the shaft speed increases, the grease temperature increases due to the heat generated by friction, thus decreasing its viscosity and the overall frictional torque.

Figure 3: Frictional Torque vs Shaft Speed (with a natural temperature increase)



As described above, the frictional torque of an oil seal varies according to the oil type and operating conditions. Figure 4 shows the relationship between the frictional torque of an oil seal and the shaft diameter (for reference only).

Figure 4: Frictional Torque vs Shaft Diameter (reference only)

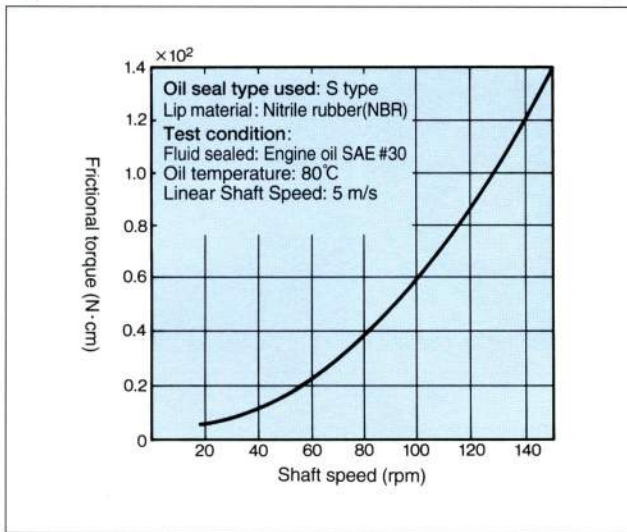

J

Service Life of an Oil Seal

The failure modes and ultimate service life will vary according to the usage conditions, including operating, environmental, and lubrication conditions.

The following will discuss the degradation of lip materials and lip wear (causing a loss of lip-to-shaft interference), which are responsible for the most common oil seal failures.

1. Lip Material Degradation

Material degradation consists of hardened or softened rubber, cracks, or taking a set. The sealing ability of an oil seal is reduced or eliminated when the lip contact area is hardened or cracked, or the lip-to-shaft interference is decreased.

This degradation often occurs as a result of a chemical reaction between the rubber and the sealing fluid, or a substance intermingled with or dissolved in the sealing fluid. Generally, degradation advances rapidly as the oil temperature increases, shortening the service life of the oil seal.

Figure 5 shows the service life of various oil seal materials vs. the temperature at the lip contact area (for reference only).

Figure 5 shows the service life of various oil seal materials vs. the temperature at the lip contact area (for reference only).

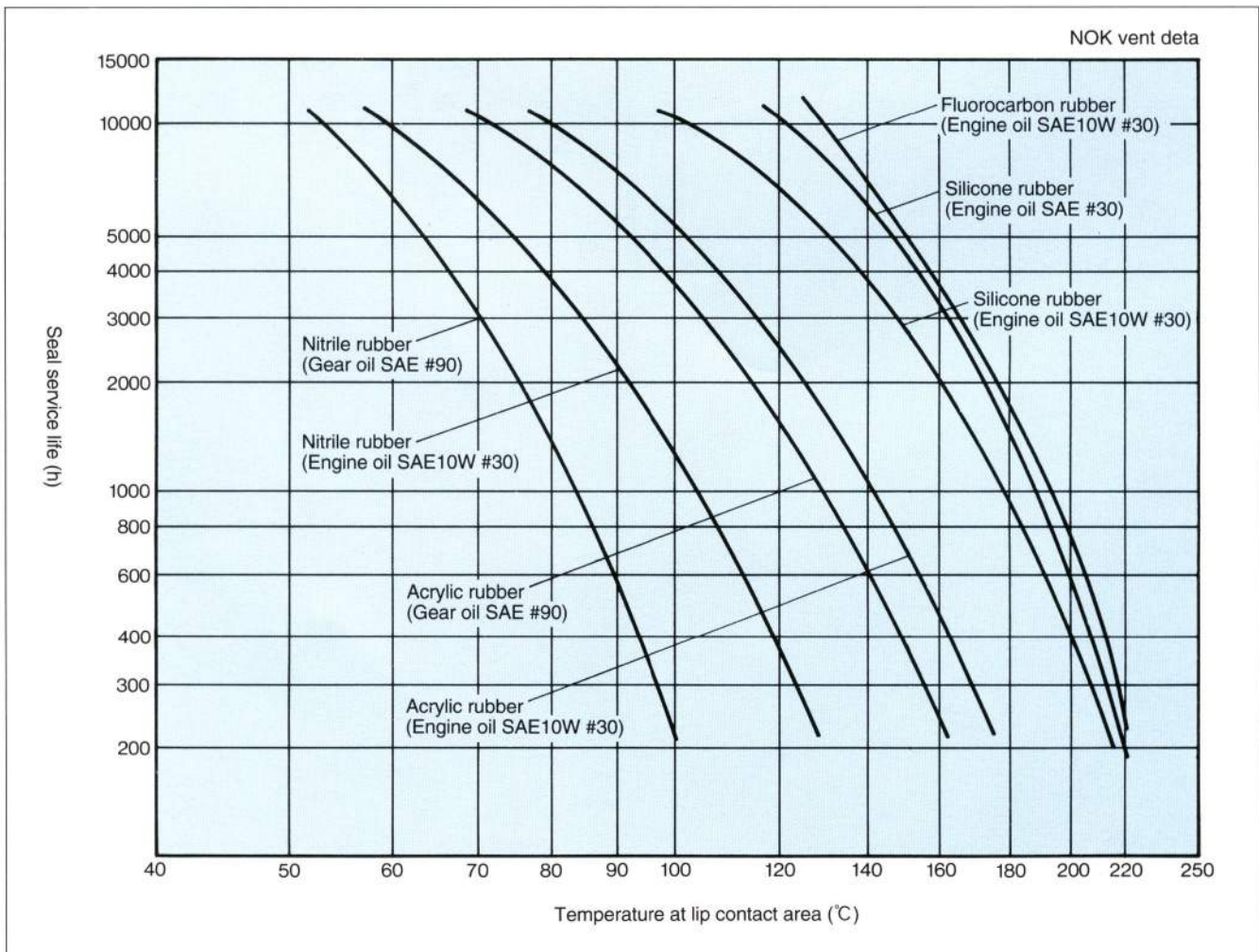

2. The Effects of Lip Wear

When there is sufficient lubrication, an oil seal continually circulates oil underneath the lip, thus minimizing lip wear. Lip wear is accelerated by a lack of or degradation of the lubricant, foreign matter trapped in the lubricant, or the entry of external dust under the main lip.

Figure 6 shows the relationship between the quantity of lubricant supplied to the lip contact area and the resulting lip wear.

Lip wear increases as the lubricant quantity decreases. However, lip wear actually progresses faster in the presence of a very small amount of lubricant than in the complete absence of lubricant.

Figure 6: Seal Lip Wear vs Oil Supply

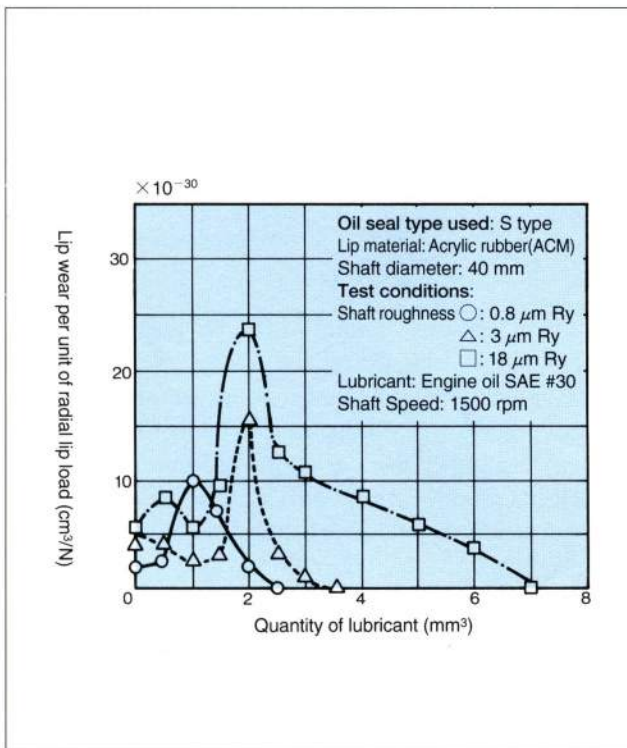

Lip wear causes lip-to-shaft interference to decrease, thereby decreasing the seal's ability to compensate for shaft eccentricity. Therefore, the life of a seal with respect to lip wear expires when the lip interference can no longer follow an eccentric shaft (shaft run-out).

Figure 7 shows an example of the shaft eccentricity limits of a worn oil seal. Leakage occurs when the lip interference value falls below approximately twice the shaft eccentricity (shaft run-out). Since the progress of lip wear is largely influenced by the quantity of lubricant or other environmental conditions, such as the presence of foreign matter in the lubricant, the performance of oil seals varies according to the actual application conditions.

Figure 7: Shaft Eccentricity Limits vs Seal Lip Interference (TIR: Total Indicator Reading)

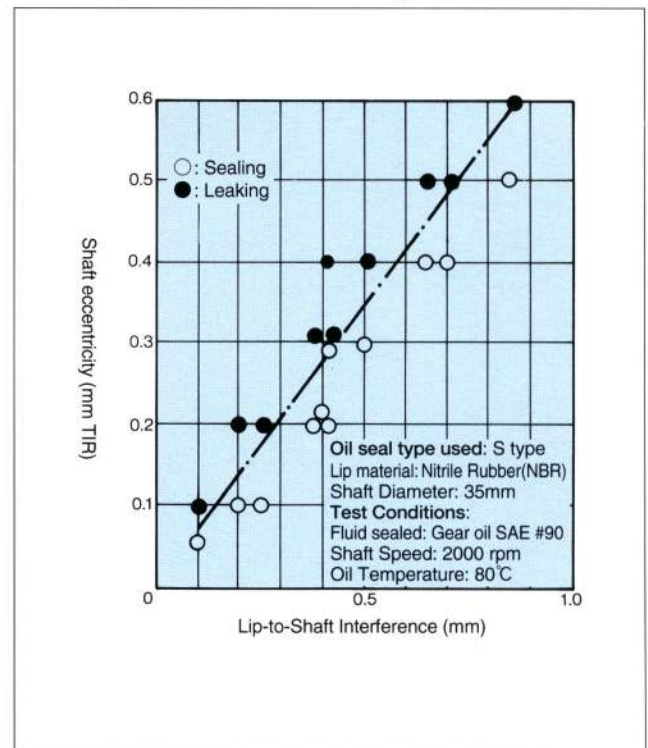

Oil and Chemical Resistance Ratings of NOK's Lip Materials

The following data is a summary of material test results. It shows the resistance of each lip material to various lubricants and chemicals.

After selecting a preliminary lip material in Chapter E, please verify its compatibility with the lubricant or chemicals to be used.

How to Read the Table

The test method used are in accordance with JIS K 6258 "Testing methods of the effect of liquids for vulcanized rubber" and JIS K 6253 "Hardness testing methods for rubber, vulcanized or thermoplastic". The table displays the test temperature and time, and the post-test changes in hardness and volume.

Hardness and volume change data indicate the post-test change in hardness against the pre-test hardness, and the post-test change in volume against the pre-test volume of the test piece, respectively. Plus (+) indicates that the hardness or volume increased after the test, while minus (-) indicates that the hardness or volume decreased after the test. The absolute value is inversely related to the oil or chemical resistance of the material.

The resistance of each lip material is determined by assuming that it is used for 500 hours continuously at the listed test temperature, and based on the indicated test results.

Symbols in the "Material Resistance Rating" column are as follows:

- ◎ : Good resistance
- : Resistance, except in special cases*
- △ : No resistance, except in special cases*
- × : No resistance

*: Consult NOK before use.

In most cases, the stability of the lip material can be determined by consulting the hardness change and volume change data; however, some materials may be classified as △ or × despite their small hardness or volume change values. Such classifications are based on other considerations and do not contradict the above-mentioned general principles.

For the classification of oil types, refer to the "Lubricant Brand Guide" published by the Lubrication News Agency. Please refer to the guide for the properties of each oil type.

There are cases in which an inorganic acid, organic acid, alkaline acid, or inorganic salt should not be used due to environmental conditions. Please consult with us before use.

Oil Resistance Data

Sealing Fluid (Manufacturer)	NOK Lip Material	Test Temperature (°C)	Test Duration (h)	Hardness Change (Durometer A) (points)	Volume Change (%)	Resistance Rating		
Engine Oils	Apoloil Auto Lube 30 SD (Idemitsu Petrochemical)		A727	100	200	0	- 0.9	◎
				120	200	0	- 0.9	○
	A941	100	200	+ 4	- 2.1	◎		
		120	200	+ 6	- 2.7	△		
	A795	100	200	+ 6	- 6.7	○		
		120	200	+ 9	- 7.5	△		
	A275	100	200	+ 5	- 8.9	◎		
		120	200	+ 6	- 9.2	△		
	T303	120	200	0	- 1.4	◎		
		130	70	- 1	+ 0.4	◎		
			500	+ 2	+ 0.3	◎		
		150	200	+ 1	- 0.6	○		
	T599	120	200	+ 2	- 1.5	◎		
		130	70	- 1	- 0.2	◎		
			500	+ 4	- 0.3	◎		
		150	70	+ 2	- 2.3	△		
			200	0	- 1.3	△		
			500	+ 6	- 3.5	△		
	T302	120	200	+ 3	+ 3.3	◎		
		150	200	+ 5	+ 4.4	○		
	S728	150	200	- 6	+ 8.8	○		
		175	200	- 9	+10.4	△		
	F585	150	200	- 2	+ 1.0	◎		
		175	200	- 2	+ 1.1	○		
	F975	150	200	+ 1	+ 2.0	◎		
		175	200	+ 3	+ 2.3	○		
	New Pan 10W-30 SG (Nippon Oil)		A727	100	200	- 5	+ 3.1	◎
				120	200	+ 2	+ 3.2	○
	A941	100	200	+ 2	+ 1.1	◎		
		120	200	+ 7	- 0.6	△		
A795	100	200	+ 5	- 4.2	◎			
	120	200	+12	- 6.1	×			
A275	100	200	- 1	- 5.7	◎			
	120	200	+ 4	- 5.3	△			
T303	120	200	0	+ 2.8	◎			
	150	200	+ 1	+ 2.6	○			
T599	120	200	+ 1	+ 1.9	◎			
	150	200	- 1	+ 2.6	△			
T302	120	200	+ 1	+ 3.3	◎			
	150	200	+ 1	+ 4.4	○			
S728	150	200	-13	+19.9	○			
	175	200	-20	+25.2	△			
F585	150	200	0	+ 1.8	◎			
	175	200	+ 2	+ 2.4	○			
F975	150	200	+ 2	+ 2.0	◎			
	175	200	+ 6	+ 2.3	○			
Shell Formula X 5W-30 SG (Showa Shell Sekiyu)		A727	100	200	- 1	- 0.1	◎	
			120	200	+13	- 0.3	×	
		A941	100	200	+ 4	- 1.1	◎	
			120	200	+ 9	- 2.6	△	
		A795	100	200	+ 7	- 5.6	△	
			120	200	+12	- 6.8	×	
A275	100	200	+ 3	- 8.6	◎			
	120	200	+ 7	- 8.7	△			

J

Oil Resistance Data

Sealing Fluid (Manufacturer)	NOK Lip Material	Test Temperature (°C)	Test Duration (h)	Hardnes Change (Durometer A) (points)	Volume Change (%)	Resistance Ratinaerial	
Engine Oils	Shell Formula X 5W-30 SG (Showa Shell Sekiyu)	T303	120	200	0	+ 1.1	⊙
			150	200	+ 1	- 0.3	○
		T599	120	200	+ 1	0	⊙
			150	200	- 1	- 0.8	△
		T302	120	200	+ 5	+ 1.5	⊙
			150	200	+ 5	+ 1.1	○
		S728	150	200	-13	+17.0	○
			175	200	-16	+20.4	△
		F585	150	200	- 4	+ 0.9	⊙
			175	200	- 1	+ 1.4	○
	F975	150	200	+ 1	+ 1.4	⊙	
		175	200	+ 3	+ 1.5	○	
	Mobil 1 5W-30 SE/CC (Mobil Sekiyu)	A727	100	200	- 1	+ 1.2	⊙
			120	200	+ 4	+ 1.1	○
		A941	100	200	+ 2	- 0.6	⊙
			120	200	+10	- 2.2	△
		A795	100	200	+ 7	- 6.0	○
			120	200	+13	- 7.0	×
		A275	100	200	+ 3	- 7.3	⊙
			120	200	+11	- 7.0	×
		T303	120	70	+ 1	+ 0.9	⊙
				200	- 1	+ 1.7	⊙
				500	+ 4	+ 0.1	⊙
			150	70	+ 1	+ 1.0	○
				200	0	+ 1.6	⊙
				500	+ 6	+ 1.0	⊙
		T599	120	200	0	+ 1.4	⊙
			150	200	- 2	+ 1.7	△
		T302	120	200	+ 1	+ 2.6	⊙
			150	200	+ 3	+ 2.4	○
S728		150	200	-14	+17.5	○	
		175	200	-18	+20.2	△	
F585	150	200	- 1	+ 1.5	⊙		
	175	200	0	+ 1.9	○		
F975	150	200	+ 3	+ 1.4	⊙		
	175	200	+ 5	+ 2.0	○		
General Motor Oil G-1 mX 5W-50 SG (General Sekiyu)	A727	100	200	+ 2	+ 0.6	⊙	
		120	200	+ 5	+ 0.1	○	
	A941	100	200	+ 3	- 1.0	⊙	
		120	200	+ 7	- 2.0	△	
	A795	100	200	+ 6	- 5.9	○	
		120	200	+12	- 7.3	×	
	A275	100	200	+ 2	- 8.1	⊙	
		120	200	+ 5	- 7.5	△	
	T303	120	200	+ 1	+ 1.4	⊙	
		150	200	+ 2	+ 1.3	○	
	T599	120	200	+ 2	+ 0.6	⊙	
		150	200	0	+ 1.2	△	
	T302	120	200	+ 3	+ 2.0	⊙	
		150	200	+ 3	+ 2.2	○	
	S728	150	200	-13	+18.3	○	
		175	200	-20	+23.2	△	
	F585	150	200	0	+ 1.7	⊙	
		175	200	+ 2	+ 2.0	○	

Oil Resistance Data

Sealing Fluid (Manufacturer)		NOK Lip Material	Test Temperature (°C)	Test Duration (h)	Hardness Change (Durometer A) (points)	Volume Change (%)	Resistance Ratio	
Engine Oils	General Motor Oil G-1 mX 5W-50 SG (General Sekiyu)	F975	150	200	+ 2	+1.5	○	
			175	200	+ 5	+1.8	○	
	Apolloil Gezelube 20CB (Idemitsu Petrochemical)	A103	100	70	0	-2.0	○	
		T303	130	70	+ 1	+2.7	○	
	High Diesel S-3 30CD (Nippon Oil)	A727	100	70	+ 1	-3.5	○	
		T303	130	70	+ 1	+0.1	○	
Gear Oils (for vehicles)	Apolloil Gear ZEX 90-GL-6 (Idemitsu Petrochemical)	A727	100	200	- 3	+3.6	○	
			120	200	+ 5	+5.1	○	
		A941	100	200	+ 2	+1.9	○	
			120	200	+ 9	+2.7	△	
		A795	100	200	+ 5	-3.3	○	
			120	200	+11	-3.7	×	
		A275	100	200	+ 4	-4.3	○	
			120	200	+11	-2.8	×	
		A437	100	200	+ 2	-1.7	○	
			120	200	+10	-0.1	△	
		A989	100	200	+ 4	-1.8	○	
			120	200	+14	-1.0	×	
		A103	100	200	+ 4	-1.6	○	
			120	200	+13	0	×	
		T303	120	200	- 3	+2.4	○	
			150	200	+ 1	+2.3	○	
		T599	120	200	- 2	+1.3	○	
			150	200	- 5	+1.7	△	
		T302	120	200	- 3	+3.6	○	
			150	200	+ 5	+4.2	△	
		S728	150	200	Immeasurable	Immeasurable	×	
			175	200	Immeasurable	Immeasurable	×	
		F585	150	200	0	+2.7	○	
			175	200	+ 4	+3.5	△	
		F975	150	200	+ 2	+2.2	○	
			175	200	+ 7	+2.5	△	
		Apolloil TH Universal 10W-30 (Idemitsu Petrochemical)	A727	100	200	- 4	+4.2	○
				120	200	- 2	+5.0	○
			A941	100	200	0	+2.4	○
				120	200	+ 6	+1.1	△
			A795	100	200	+ 4	-3.0	○
				120	200	+10	-4.8	△
			A275	100	200	+ 4	-4.7	○
				120	200	+ 3	-4.0	△
			A437	100	200	+ 2	-1.0	○
				120	200	+ 3	-0.2	△
A989	100		200	0	-0.5	○		
	120		200	+ 3	-0.9	△		
A103	100		200	- 1	-1.6	○		
	120		200	+ 3	-1.4	△		
T303	120		200	- 2	+3.8	○		
	150		200	- 1	+3.6	○		
T599	120		200	- 2	+3.7	○		
	150		200	- 3	+3.4	△		

Oil Resistance Data

Sealing Fluid (Manufacturer)	NOK Lip Material	Test Temperature (°C)	Test Duration (h)	Hardnes Change (Durometer A) (points)	Volume Change (%)	Resistance Rating	
Apolloil TH Universal 10W-30 (Idemitsu Petrochemical)	T302	120	200	- 2	+ 4.7	◎	
		150	200	- 2	+ 5.0	○	
	S728	150	200	-16	+20.1	✕	
		175	200	-33	+20.6	✕	
	F585	150	200	- 2	+ 1.8	◎	
		175	200	- 1	+ 2.8	△	
	F975	150	200	+ 2	+ 1.9	◎	
		175	200	+ 4	+ 2.8	△	
	Gear Lube EHD 80·GL-5 (Nippon Oil)	A727	100	200	- 3	+ 1.9	◎
			120	200	+ 2	+ 2.6	○
A941		100	200	+ 4	+ 0.5	◎	
		120	200	+ 9	+ 0.5	△	
A795		100	200	+ 6	- 4.6	○	
		120	200	+11	- 5.3	✕	
A437		100	200	+ 5	- 3.2	○	
		120	200	+ 9	- 2.7	△	
A989		100	200	+ 5	- 3.0	○	
		120	200	+11	- 3.0	△	
A103		100	200	+ 4	- 3.3	◎	
		120	200	+10	- 2.8	△	
T303		120	200	+ 1	+ 1.2	◎	
		150	200	+ 2	+ 1.3	○	
T599		120	200	+ 1	+ 0.4	◎	
		150	200	- 1	+ 0.7	△	
T302		120	200	0	+ 2.3	◎	
		150	200	+ 5	+ 2.3	○	
S728		150	200	Immeasurable	Immeasurable	✕	
		175	200	Immeasurable	Immeasurable	✕	
F585	150	200	0	+ 1.7	◎		
	175	200	+ 5	+ 2.3	△		
F975	150	200	+ 4	+ 1.2	◎		
	175	200	+ 7	+ 1.5	△		
Spilacs EP90·GL-4 (Showa Shell Sekiyu)	A727	100	200	- 2	+ 0.6	◎	
		120	200	+ 5	+ 1.1	○	
	A941	100	200	+ 3	- 0.4	◎	
		120	200	+ 7	- 0.6	△	
	A795	100	200	+ 6	- 5.4	○	
		120	200	+11	- 6.3	✕	
	A275	100	200	+ 6	- 7.3	○	
		120	200	+11	- 7.3	✕	
	A437	100	200	+ 4	- 4.7	◎	
		120	200	+10	- 4.1	△	
	A989	100	200	+ 6	- 3.8	○	
		120	200	+12	- 3.9	✕	
A103	100	200	+ 5	- 4.0	○		
	120	200	+11	- 4.0	✕		

Gear Oils (for vehicles)

J

Oil Resistance Data

Sealing Fluid (Manufacturer)	NOK Lip Material	Test Temperature (°C)	Test Duration (h)	Hardnes Change (Durometer A) (points)	Volume Change (%)	Resistance Rating		
Gear Oils (for vehicles)	Spilacs EP90·GL-4 (Showa Shell Sekiyu)	T303	120	200	0	- 0.3	○	
			150	200	+ 3	+ 0.3	○	
		T599	120	200	- 1	- 1.0	○	
			150	200	- 2	- 0.8	△	
		T302	120	200	0	+ 1.5	○	
			150	200	+ 5	+ 1.5	○	
		S728	150	200	- 6	- 0.2	△	
			175	200	- 8	- 3.2	×	
		F585	150	200	0	+ 1.4	○	
			175	200	+ 2	+ 2.0	△	
		F975	150	200	+ 4	+ 1.0	○	
			175	200	+ 6	+ 1.0	△	
		Apolloil Gear HE 90·GL-4 (Idemitsu Petrochemical)	T303	90	480	- 2	+ 6.4	○
				110	240	- 2	+ 6.2	○
		Apolloil Wide Gear LW 80W-90·GL-5 (Idemitsu Petrochemical)	T303	120	70	+ 1	0	○
200	+ 2				- 0.1	○		
500	+ 2				+ 0.5	○		
150	200			+ 3	+ 0.1	○		
			500	+ 6	- 0.3	○		
Gear Lube SP 90·GL-4 (Nippon Oil)	A727	120	70	+ 2	- 1.2	○		
			A795	120	70	+ 6	- 7.0	△
			T599	80	70	- 1	- 0.7	○
Antoil B 80W (Nippon Oil)	A727	100	70	- 6	+ 1.8	○		
Diamond EP Gear Oil 80·GL-3 (Mitsubishi Oil)	A727	100	70	- 1	- 0.3	○		
			A795	100	70	0	- 2.9	○
Diamond EP Gear Oil 90·GL-3 (Mitsubishi Oil)	A727	100	70	0	+ 0.2	○		
			T303	100	70	- 2	+ 1.6	○
Diamond Hypoid Gear Oil 90·GL-4 (Mitsubishi Oil)	T303	130	70	+ 1	+ 0.7	○		
			500	+ 5	+ 1.2	○		
		150	70	+ 1	+ 1.0	○		
			300	+ 6	+ 1.0	○		
		500	+ 9	- 3.5	○			
			T599	100	70	0	- 0.9	○
Class 2 Gear Oils for Industrial Use (Extreme Pressure)	(Polyglycol base) Synthese D68EP (NOK Kluber)	A727	100	200	- 8	+ 7.2	○	
			120	200	-13	+12.4	△	
		A941	100	200	- 1	+ 4.1	○	
			120	200	- 1	+ 5.6	○	
		A795	100	200	+ 2	- 2.1	○	
			120	200	+ 4	- 1.8	○	
		A275	100	200	- 2	+ 0.3	○	
			120	200	- 2	+ 1.6	○	
		A437	100	200	- 1	+ 5.6	○	
			120	200	- 5	+ 3.1	○	
		A989	100	200	- 2	+ 1.3	○	
			120	200	- 3	+ 1.0	○	
		A103	100	200	- 2	+ 2.6	○	
			120	200	- 3	+ 2.0	○	
T303	120	200	-24	+45.1	×			
	150	200	-26	+59.5	×			



Oil Resistance Data

Sealing Fluid (Manufacturer)	NOK Lip Material	Test Temperature (°C)	Test Duration (h)	Hardnes Change (Durometer A) (points)	Volume Change (%)	Resistance Ratiuaerial	
(Polyglycol base) Synthese D68EP (NOK Kluber)	T599	120	200	-25	+47.5	×	
		150	200	-34	+69.1	×	
	T302	120	200	-20	+80.8	×	
		150	200	-22	+57.0	×	
	S728	150	200	-6	-0.2	△	
		175	200	Immeasurable	Immeasurable	×	
	F585	150	200	-1	+1.4	⊙	
		175	200	+1	+2.0	△	
	F975	150	200	+3	+1.4	⊙	
		175	200	+6	+0.9	△	
	(Polyglycol base) Synthese D460EP (NOK Kluber)	A727	100	200	-1	-2.2	⊙
			120	200	0	-2.0	○
		A941	100	200	+4	-2.6	⊙
			120	200	+3	-2.5	○
A795		100	200	+6	-6.6	○	
		120	200	+7	-7.1	△	
A275		100	200	+2	-9.5	⊙	
		120	200	+3	-9.1	○	
A437		100	200	+5	-7.3	⊙	
		120	200	+5	-7.5	○	
A989		100	200	+5	-6.8	⊙	
		120	200	+5	-6.7	○	
A103		100	200	+3	-7.1	⊙	
		120	200	+4	-6.8	○	
T303		120	200	-8	+8.5	⊙	
		150	200	-7	+11.9	○	
T599		120	200	-9	+10.4	○	
		150	200	-14	+13.9	△	
T302		120	200	-10	+14.0	△	
		150	200	-10	+17.8	△	
S728		150	200	Immeasurable	Immeasurable	×	
		175	200	Immeasurable	Immeasurable	×	
F585		150	200	+4	+1.7	⊙	
		175	200	+11	+3.3	×	
F975		150	200	+5	+1.1	⊙	
		175	200	+11	+1.9	×	
(Polyglycol base) Synthese HT220 (NOK Kluber)		A727	100	200	-3	+1.7	⊙
			120	200	-4	+2.5	○
	A941	100	200	+2	-0.7	⊙	
		120	200	+3	0	○	
	A795	100	200	+5	-5.4	⊙	
		120	200	+6	-5.7	○	
	A275	100	200	+1	-5.0	⊙	
		120	200	+1	-5.1	○	
	A437	100	200	+3	-2.9	⊙	
		120	200	+4	-2.9	○	

Class 2 Gear Oils for Industrial Use (Extreme Pressure)

J

Oil Resistance Data

Sealing Fluid (Manufacturer)	NOK Lip Material	Test Temperature (°C)	Test Duration (h)	Hardnes Change (Durometer A) (points)	Volume Change (%)	Resistance Rating	
(Polyglycol base) Synthese HT220 (NOK Kluber)	A989	100	200	+ 2	- 3.3	⊙	
		120	200	+ 4	- 3.3	○	
	A103	100	200	+ 2	- 2.9	⊙	
		120	200	+ 3	- 3.0	○	
	T303	120	200	-11	+19.1	✕	
		150	200	- 8	+23.0	✕	
	T599	120	200	-16	+24.7	✕	
		150	200	-21	+32.2	✕	
	T302	150	200	-11	+28.9	✕	
		175	200	- 8	+30.9	✕	
	S728	150	200	+ 1	+ 1.7	○	
		175	200	0	+ 1.8	△	
	F585	150	200	- 3	+ 0.7	⊙	
		175	200	+ 2	+ 1.5	△	
	F975	150	200	0	+ 0.5	⊙	
		175	200	+ 6	+ 1.3	△	
	(Polyglycol base) Synthese HT680 (NOK Kluber)	A727	100	200	- 1	- 2.4	⊙
			120	200	- 1	- 2.7	○
		A941	100	200	+ 4	- 2.9	⊙
			120	200	+ 5	- 3.4	○
A795		100	200	+ 6	- 6.8	○	
		120	200	+ 8	- 8.1	△	
A275		100	200	+ 5	-10.0	○	
		120	200	+ 5	-10.0	△	
A437		100	200	+ 6	- 8.3	○	
		120	200	+ 7	- 8.7	△	
A989		100	200	+ 5	- 6.7	○	
		120	200	+ 7	- 7.3	△	
A103		100	200	+ 4	- 8.7	⊙	
		120	200	+ 5	- 7.1	△	
T303		120	200	- 5	+ 5.4	⊙	
		150	200	+ 1	+ 8.0	○	
T599		120	200	- 8	+ 7.5	○	
		150	200	-12	+12.2	△	
T302		120	200	- 4	+ 9.0	⊙	
		150	200	+ 2	+11.7	○	
S728	150	200	+ 3	+ 0.6	○		
	175	200	+ 3	+ 0.3	△		
F585	150	200	- 3	+ 0.8	⊙		
	175	200	+ 4	+ 1.5	△		
F975	150	200	+ 1	+ 0.6	⊙		
	175	200	+ 8	+ 1.2	△		
Machine oil (spindle oil)	A727	80	200	-14	+20.7	✕	
		100	70	-11	+25.1	✕	
		200		-14	+22.2	✕	
	A275	80	200	- 7	+12.1	△	
		100	200	- 8	+12.2	△	

J

Oil Resistance Data

Sealing Fluid (Manufacturer)	NOK Lip Material	Test Temperature (°C)	Test Duration (h)	Hardnes Change (Durometer A) (points)	Volume Change (%)	Resistance Ratinaerial
Machine oil (spindle oil)	No.1 Spindle oil (Nippon Oil)					
	A103	100	70	-16	+31.0	×
	G418	80	200	-7	+11.3	△
		100	200	-7	+11.3	△
	T303	80	200	-11	+12.5	△
		100	200	-10	+12.8	△
	T599	80	200	-8	+12.5	△
		100	200	-9	+12.8	△
	T302	80	200	-10	+13.8	△
		100	200	-13	+15.7	△
	S728	80	200	-15	+39.4	×
		100	200	-16	+42.6	×
	F585	80	200	-4	+2.0	◎
		100	200	-4	+3.4	◎
	F548	80	200	0	+1.2	◎
		100	200	-1	+2.9	◎
	F975	80	200	-2	+1.6	◎
		100	200	-2	+3.1	◎
	Machine oil (spindle oil)	No.2 Spindle oil (Nippon Oil)				
A727		100	200	-8	+11.1	○
		120	200	-10	+11.7	△
A275		100	200	-2	+2.8	○
		120	200	-3	+3.3	○
A103		130	70	-12	+12.4	△
G418		120	200	-1	+3.3	○
		150	200	-1	+3.4	△
T303		120	200	-2	+5.8	○
		150	200	-1	+6.5	○
T599		120	200	-3	+5.8	○
		150	200	-3	+6.5	△
T302		120	200	-3	+7.1	○
		150	200	+2	+7.3	○
S728		120	200	-13	+23.1	×
		150	200	-15	+27.4	×
F585		120	200	-3	+6.8	◎
		150	200	-4	+7.7	◎
F548		120	200	0	+1.6	◎
	150	200	0	+2.4	◎	
F975	120	200	-1	+2.0	◎	
	150	200	-1	+3.1	◎	
Class 2 turbine oil	Shell Turbo Oil T32 (Showa Shell Sekiyu)					
	A727	100	200	+1	-0.5	◎
		120	200	+1	-0.5	○
	A941	100	200	-2	-2.7	◎
		120	200	0	-2.9	○
	A275	100	200	+6	-8.5	○
		120	200	+10	-8.7	△
	T303	120	200	+1	-0.8	◎
150		200	+3	-0.8	○	
S728	150	200	-13	+13.9	△	

Oil Resistance Data

Sealing Fluid (Manufacturer)		NOK Lip Material	Test Temperature (°C)	Test Duration (h)	Hardnes Change (Durometer A) (points)	Volume Change (%)	Resistance Ratio
Class 2 turbine oil	Shell Turbo Oil T32 (Showa Shell Sekiyu)	S728	175	200	-19	+17.5	×
		F585	150	200	-3	+1.3	○
			175	200	-3	+1.9	○
	Shell Turbo Oil T68 (Showa Shell Sekiyu)	A727	100	200	+1	-2.1	○
			120	200	+3	-2.1	○
		A941	100	200	+5	-2.9	○
			120	200	+5	-3.1	○
		A275	100	200	+14	-8.5	×
			120	200	+15	-8.7	×
		T303	120	200	+1	-1.3	○
			150	200	+2	-1.4	○
		S728	150	200	-7	+9.4	○
			175	200	-11	+11.4	△
		F585	150	200	-2	+0.6	○
			175	200	-2	+0.9	○
Torque converter oil / Automatic Transmission Fluid	Apolloil Mission Fluid (Idemitsu Petrochemical)	A727	100	200	-2	+2.8	○
			120	200	0	+2.5	○
		A941	100	200	+3	+0.9	○
			120	200	+6	-0.2	△
		A795	100	200	+5	-3.9	○
			120	200	+11	-5.9	×
		A275	100	200	+3	-5.7	○
			120	200	+1	-5.6	○
		G418	120	200	+5	-4.3	○
			150	200	+7	-3.6	△
		T303	120	200	-1	+1.6	○
			150	200	+2	+1.5	○
		T599	120	200	-1	+1.5	○
			150	200	-3	+2.1	△
		T302	120	200	+2	+3.1	○
			150	200	+3	+3.4	○
		S728	150	200	-15	+20.6	×
			175	200	-27	+22.1	×
	F585	150	200	-1	+1.9	○	
		175	200	+2	+2.4	○	
	F975	150	200	+2	+1.6	○	
		175	200	+4	+2.1	○	
	Pegasus Torque Converter Fluid (Mobil Sekiyu)	A727	100	200	-3	+6.1	○
			120	200	-3	+6.1	○
		A941	100	200	+1	+3.5	○
			120	200	+2	+3.2	○
		A795	100	200	+5	-1.7	○
		120	200	+6	-2.7	△	
A275		100	200	+2	-2.5	○	
		120	200	+2	-2.0	△	
G418		120	200	+2	-1.1	○	
		150	200	+4	-1.6	△	
T303		120	200	-3	+4.6	○	
		150	200	-2	+6.0	○	
T599		120	200	-1	+4.5	○	
		150	200	-2	+6.3	△	
T302		120	200	-1	+6.3	○	
		150	200	0	+9.0	○	
S728		150	200	-18	+34.8	×	

Oil Resistance Data

	Sealing Fluid (Manufacturer)	NOK Lip Material	Test Temperature (°C)	Test Duration (h)	Hardnes Change (Durometer A) (points)	Volume Change (%)	Resistance Ratinaerial	
Automatic Transmission Fluid	Pegasus Torque Converter Fluid (Mobil Sekiyu)	S728	175	200	-22	+39.7	×	
		F585	150	200	-4	+3.2	○	
			175	200	-5	+4.0	○	
		F975	150	200	-2	+3.2	○	
			175	200	-2	+3.9	○	
	Apolloil ATF D-2 (Idemitsu Petrochemical)	A727		100	70	-4	+2.8	◎
				120	70	-5	+3.5	○
				140	70	-6	+4.2	○
		A103		100	70	-2	-1.2	◎
				120	70	-2	-1.5	△
			140	70	-2	-2.0	△	
		T599		135	70	-2	+4.4	◎
				300	70	0	+4.1	◎
				500	70	0	+3.9	◎
			150	70	-2	+4.8	○	
			300	70	-1	+4.4	○	
			500	70	0	+4.0	○	
		T303		120	70	-2	+4.0	◎
				500	70	+2	+3.2	◎
				150	70	-1	+3.9	◎
			300	70	+3	+2.9	◎	
			500	70	+3	+2.8	◎	
			165	70	+4	+2.8	△	
			150	70	+7	+2.3	△	
		S728		150	70	-15	+29.7	×
			500	70	-24	+31.1	×	
			175	70	-25	+35.5	×	
	F384		500	70	-40	+38.7	×	
			150	70	0	+0.5	△	
		200	70	+1	+0.2	△		
Mobil ATF 200 (Idemitsu Petrochemical)	A727		130	70	0	+5.4	△	
			200	70	+3	-9.6	△	
	A103		130	70	+2	-1.2	△	
			200	70	+5	-2.6	△	
	T303		130	70	0	+5.0	◎	
		200	70	+2	+4.4	◎		
Hydraulic actuation oil/General purpose oil for industrial use (additive)	Duffny Hydraulic Fluid 32 (Idemitsu Petrochemical)	A727	100	200	+2	-0.4	◎	
			120	200	+1	+0.1	○	
		A941	100	200	+4	-1.5	◎	
			120	200	+6	-1.3	△	
		A795	100	200	+8	-5.4	○	
			120	200	+11	-6.1	×	
		A275	100	200	+7	-7.9	○	
			120	200	+9	-8.3	△	
		A437	100	200	+6	-4.8	○	
			120	200	+8	-4.9	△	
		A989	100	200	+6	-3.8	○	
			120	200	+7	-3.8	△	
		A103	100	200	+3	-4.6	○	
			120	200	+4	-4.9	△	
		G418	120	200	+7	-6.8	○	
150	200		+10	-6.8	△			
T303	120	200	0	-0.3	◎			
	150	200	+2	-0.1	○			

Oil Resistance Data

Sealing Fluid (Manufacturer)	NOK Lip Material	Test Temperature (°C)	Test Duration (h)	Hardnes Change (Durometer A) (points)	Volume Change (%)	Resistance Ratinaerial
Hydraulic actuation oil / General purpose oil for industrial use (additive)	Duffny Hydraulic Fluid 32 (Idemitsu Petrochemical)					
	T599	120	200	+ 2	- 0.7	⊙
		150	200	0	- 0.5	△
	T302	120	200	- 3	+ 1.5	⊙
		150	200	- 2	+ 2.0	○
	S728	150	200	-19	+17.0	○
		175	200	-22	+17.6	×
	F585	150	200	0	+ 0.9	⊙
		175	200	+ 1	+ 1.3	○
	F975	150	200	+ 1	+ 1.6	⊙
		175	200	+ 3	+ 1.7	○
	F548	150	200	0	+ 0.9	⊙
		175	200	+ 1	+ 1.3	○

	Shell Terrace Oil C10 (Showa Shell Sekiyu)					
	A727	100	200	- 5	+ 6.9	⊙
		120	200	- 5	+ 7.7	○
	A941	100	200	0	+ 4.0	⊙
		120	200	+ 2	+ 4.0	△
	A795	100	200	+ 4	- 1.8	○
		120	200	+ 6	- 2.6	△
	A275	100	200	+ 2	- 1.6	⊙
		120	200	+ 3	- 0.8	△
	A989	100	200	- 2	+ 1.8	⊙
		120	200	+ 1	+ 2.1	△
	A103	100	200	- 1	+ 2.0	⊙
		120	200	+ 1	+ 1.7	△
	G418	120	200	+ 2	- 0.9	⊙
		150	200	+ 4	- 0.6	△
	T303	120	200	- 4	+ 5.2	⊙
150		200	- 3	+ 6.6	○	
T599	120	200	- 2	+ 4.8	⊙	
	150	200	- 4	+ 7.2	△	
T302	120	200	- 3	+ 7.2	⊙	
	150	200	- 2	+ 9.8	△	
S728	150	200	-24	+50.9	×	
	175	200	-28	+61.1	×	
F585	150	200	- 4	+ 3.9	⊙	
	175	200	- 4	+ 4.9	○	
F975	150	200	- 1	+ 3.9	⊙	
	175	200	- 2	+ 4.8	○	
F548	150	200	- 1	+ 2.7	⊙	
	175	200	- 1	+ 3.5	○	

Shell Terrace Oil C46 (Showa Shell Sekiyu)						
A727	100	200	- 3	+ 1.5	⊙	
	120	200	- 4	+ 1.1	○	
A941	100	200	+ 3	- 0.4	⊙	
	120	200	+ 5	- 0.4	△	
A795	100	200	+ 7	- 0.5	○	
	120	200	+ 8	- 1.4	△	
A275	100	200	+ 5	- 6.7	○	
	120	200	+ 6	- 6.5	△	
A437	100	200	+ 4	- 8.0	⊙	
	120	200	+ 4	-10.5	△	

J

Oil Resistance Data

Sealing Fluid (Manufacturer)	NOK Lip Material	Test Temperature (°C)	Test Duration (h)	Hardnes Change (Durometer A) (points)	Volume Change (%)	Resistance Ratinaerial	
Hydraulic actuation oil/General purpose oil for industrial use (additive)	Shell Terrace Oil C46 (Showa Shell Sekiyu)	A989	100	200	+ 4	- 3.2	○
			120	200	+ 6	- 3.4	△
	A103	100	200	+ 2	- 3.9	○	
		120	200	+ 3	- 4.5	○	
	G418	120	200	+ 5	- 5.8	○	
		150	200	+ 7	- 5.8	△	
	T303	120	200	- 1	+ 0.3	○	
		150	200	+ 2	+ 0.3	○	
	T599	120	200	- 2	0	○	
		150	200	0	+ 0.1	△	
	T302	120	200	+ 2	+ 1.8	○	
		150	200	+ 5	+ 2.3	○	
	S728	150	200	- 11	+ 13.8	○	
		175	200	- 14	+ 16.5	△	
	F585	150	200	- 4	+ 1.6	○	
		175	200	- 5	+ 2.1	○	
	F975	150	200	+ 1	+ 1.5	○	
		175	200	0	+ 1.5	○	
	F548	150	200	- 1	+ 1.1	○	
		175	200	0	+ 1.4	○	
Duffny Neofluid 46 (Idemitsu Petrochemical)	A795	100	70	- 12	+ 20.5	×	
	F384	100	70	- 9	+ 9.6	○	
Duffny Super Hydro LW 46 (Idemitsu Petrochemical)	A727	100	70	0	- 1.1	○	
	A795	100	70	+ 6	- 5.4	○	
	F384	100	70	0	+ 0.1	○	
Mulpose 32 (Nippon Oil)	A727	80	168	- 2	+ 0.8	○	
	T303	80	168	- 2	+ 0.7	○	
Unipower SQ 32 (Esso Sekiyu)	A727	100	70	- 2	+ 0.5	○	
			166	0	+ 1.2	○	
Unipower SQ 46 (Esso Sekiyu)	A727	100	70	0	- 0.1	○	
			166	+ 1	+ 0.3	○	
Unipower SQ 68 (Esso Sekiyu)	A727	100	70	0	- 0.7	○	
			166	+ 1	- 0.4	○	
Mobil Velocity Oil No. 3 (Mobil Oil)	A727	80	168	- 13	+ 12.0	○	
Mobil Velocity Oil No. 6 (Mobil Oil)	A727	80	168	- 8	+ 5.7	○	
Kyoseki Hydolux 32(Kyodo Oil)	A727	80	168	- 3	+ 0.2	○	
	A795	80	168	+ 1	- 3.5	○	
	T303	80	168	- 2	+ 0.3	○	
(Phosphoric ester base) Highland FRP46 (Nippon Oil)	A727	100	200	- 40	+ 149.4	×	
		120	200	- 66	+ 202.9	×	
	A795	100	200	- 30	+ 97.4	×	
		120	200	- 40	+ 123.7	×	
	A437	100	200	- 25	+ 93.3	×	
		120	200	- 28	+ 117.6	×	
	T303	100	200	- 26	+ 98.4	×	
		150	200	- 32	+ 123.1	×	
	S728	100	200	- 2	+ 3.2	○	
		150	200	- 7	+ 7.7	△	
	F585	100	200	- 10	+ 14.5	△	
		150	200	- 13	+ 19.5	×	
F384	100	200	- 3	+ 4.0	○		
		150	200	- 4	+ 6.6	○	

Oil Resistance Data

Sealing Fluid (Manufacturer)		NOK Lip Material	Test Temperature (°C)	Test Duration (h)	Hardness Change (Durometer A) (points)	Volume Change (%)	Resistance Ratio
Fire resistant fluid	(Phosphoric ester base) Highland FRP46 (Nippon Oil)	F548	100	200	- 4	+ 12.1	△
			150	200	- 7	+ 16.2	×
	(Water+glycol base) Moresuco Hydoll HAW (Matsumura Sekiyu)	A727	80	200	+ 4	+ 5.7	△
		T303	80	200	-31	+ 29.0	×
		S728	80	200	- 1	+ 4.7	×
		F585	80	200	+ 1	+ 4.7	○
		F975	80	200	+ 2	+ 4.9	○
	(Water+glycol base) Kosumo Fluid HQ 46 (Kosumo Oil)	A727	80	168	- 3	+ 0.2	△
		A103	80	70	- 7	+ 2.1	△
		A795	60	70	- 4	+ 2.1	△
			80	70	- 5	+ 5.2	△
		F384	80	70	- 5	+ 9.3	○
	(Water+glycol base) Naiback FR200 Fluid (Mobil Sekiyu)	A103	80	70	- 7	+ 1.8	△
		A795	80	70	- 5	+ 3.0	△
		F384	80	70	- 5	+ 7.5	○
	(Water+glycol base) Mobil Hydro Fluid HFC (Mobil Sekiyu)	A103	80	70	- 9	+ 7.7	△
		F384	80	70	-11	+ 16.2	△
	(Water+glycol base) Kyoseki Hydoria G(Kyoseki Sekiyu)	A103	80	70	- 6	- 0.5	△
	(Oil+water emulsion base) Horto Safe 5040 (E.F. Horton & Co.)	A103	100	70	- 9	+ 6.8	◎
		S728	100	70	-17	+ 39.0	×
Gasoline	Idemitsu 100 Gasoline (High-octane gasoline) (Idemitsu Petrochemical)	A727	25	200	-24	+ 50.1	×
		A795	25	200	-16	+ 23.9	△
		T303	25	200	-25	+ 53.0	×
		S728	25	200	-16	+110.5	×
		F585	25	200	- 4	+ 4.1	△
		F384	25	200	- 2	+ 3.2	◎
	Regular Gasoline (General Sekiyu)	A795	25	24	-11	+ 21.6	△
			25	72	-15	+ 29.3	△
		F585	25	70	- 1	+ 1.0	△
		F384	25	70	- 1	+ 1.0	◎
	Nonleaded High-octane Gasoline (Mitsubishi Oil)	F975	25	70	- 2	+ 1.8	△
	Magnum 100 (Kosumo Oil)	A795	25	24	-15	+ 34.3	×
			25	72	-17	+ 30.1	×
	Esso Extra (Esso Sekiyu)	A795	25	24	-16	+ 34.8	×
			25	72	-17	+ 30.2	×
Formula Shell Super X (Show Shell Sekiyu)	A795	25	24	-17	+ 34.4	×	
		25	72	-17	+ 31.4	×	
Light oil / Kerosene / Heavy oil	Light oil (JIS No.2)	A727	25	200	- 5	+ 6.6	×
		A795	25	200	+ 3	+ 2.0	△
		T303	25	200	- 3	+ 1.9	×
		S728	25	200	-13	+ 44.7	×
		F585	25	200	0	- 0.2	△
		F384	25	200	0	- 0.2	◎
	Kerosene	A795	25	200	- 1	+ 3.3	△
		T303	80	168	-11	+ 13.9	×
		F384	25	200	0	+ 0.2	◎
	Heavy oil (C heavy oil)	A727	50	200	- 7	- 7.8	×
		A795	50	200	0	- 2.8	△
		A941	50	200	- 2	- 6.3	△

Oil Resistance Data

Sealing Fluid (Manufacturer)		NOK Lip Material	Test Temperature (°C)	Test Duration (h)	Hardness Change (Durometer A) (points)	Volume Change (%)	Resistance Ratio	
Heavy oil	Heavy oil (C heavy oil)	T303	50	200	- 5	- 3.5	×	
		S728	50	200	- 5	-11.6	×	
		F585	50	200	- 2	- 0.5	△	
		F384	50	200	0	- 0.3	◎	
Cutting fluid	Similon VLQ-25 (Daido Chemicals)	A727	100	70	+ 2	+ 4.2	○	
	Shell Macron Oil 27 (Showa Shell Sekiyu)	S728	120	70	-12	+30.5	×	
Rust preventive oil	Standard Anti-rust ND32 (Mobil Sekiyu)	A103	120	70	-10	+13.3	○	
		S728	120	70	-10	+58.8	×	
Insulating oil	Insulating Oil JIS No.2 (Nihon Sekiyu)	A103	100	70	- 5	+ 7.3	○	
	Insulating Oil JIS No.3 (Idemitsu Petrochemical)	A103	100	70	- 6	+11.5	○	
	Cable Filler No.58	A103	100	70	+ 2	- 2.8	○	
		S728	120	70	- 1	+ 4.2	◎	
Grease	Auto Lex A (Idemitsu Petrochemical)	A727	100	70	- 2	+ 0.9	◎	
				200	- 2	+ 1.1	◎	
		A941	100	200	+ 1	0	◎	
		A795	100	200	+ 5	- 4.7	◎	
		A275	100	200	+ 3	- 7.2	◎	
		A437	100	200	+ 5	- 4.2	◎	
		A571	100	200	+ 1	- 3.3	◎	
		A368	100	200	- 2	+ 2.2	◎	
		A103	100	70	+ 1	- 1.7	◎	
				200	+ 2	- 4.7	◎	
		T303	100	70	- 2	+ 2.4	◎	
				200	- 2	- 0.4	◎	
		T599	100	200	- 3	- 0.1	◎	
		T302	100	200	- 1	+ 1.7	◎	
		S728	100	200	- 2	+ 5.0	◎	
		S817	100	200	- 4	+ 4.7	◎	
		F585	100	200	- 4	+ 0.3	◎	
		F975	100	200	0	+ 0.2	◎	
		(Fluorocarbon oil base) SEALUB S-11 (NOK Kluber)	A727	100	200	+ 2	- 1.1	◎
			A941	100	200	+ 4	- 0.7	◎
			A795	100	200	+ 4	- 1.8	◎
			A275	100	200	+ 2	- 2.9	◎
			A437	100	200	+ 3	- 2.8	◎
			A571	100	200	+ 3	- 1.5	◎
			A368	100	200	+ 2	- 0.5	◎
			A103	100	200	+ 2	- 1.6	◎
T303	100		200	- 3	- 1.0	◎		
T599	100		200	- 1	- 1.1	◎		
T302	100		200	+ 1	0	◎		
S728	100		200	+ 3	- 0.7	◎		
S817	100		200	- 1	+ 1.0	◎		
F585	100		200	- 1	0	◎		
F975	100		200	- 1	- 0.6	◎		
(Mineral oil base) DUOTEMP PASTE (NOK Kluber)	A727		100	70	- 3	+ 1.5	◎	
		250		- 2	+ 1.1	◎		
		T303		100	70	- 1	+ 0.4	◎
(Ester base) ISOFLEX NBU 15 (NOK Kluber)	A727	70	70	- 1	+ 0.2	◎		
			70	- 3	+ 3.3	◎		

Oil Resistance Data

	NOK Lip Material	Test Temperature (°C)	Test Duration (h)	Hardnes Change (Durometer A) (points)	Volume Change (%)	Resistance Rating		
Grease	(Ester base) ISOFLEX NBU 15 (NOK Kluber)	F384	70	70	0	- 0.2	◎	
	(Mineral oil base) SEALUB S-1 (NOK Kluber)	A727	100	70	- 1	+ 0.6	◎	
		A103	100	70	- 2	- 2.1	◎	
		A275	80	70	+ 1	- 7.1	◎	
		A571	100	70	0	- 1.8	◎	
		T599	120	70	+ 3	+ 3.3	◎	
				150	70	- 2	+ 2.9	◎
	(Poly α olefin base) SEALUB S-14 (NOK Kluber)	A727	100	70	0	- 0.8	◎	
		A103	70	70	0	- 3.5	◎	
			100	70	- 3	- 4.8	◎	
		T303	150	70	+ 3	- 0.8	◎	
		S728	150	70	- 8	+ 15.0	◎	
	(Mineral base) Anbligon TA 30/0 (NOK Kluber)	A727	100	70	+ 1	- 1.4	◎	
	Beacon 325 (Esso)	A727	70	70	-17	+ 23.0	✕	
		A103	60	70	-10	+ 10.1	△	
	O.S. Grease No. 1 (Kyodo Oil and Fat)	A727	100	70	- 1	+ 2.7	◎	
		T303	130	70	- 5	+ 1.4	◎	
	Multemp MS No. 2 (Kyodo Oil and Fat)	A727	70	70	-19	+ 30.7	✕	
	Multi Knock Urea (Nihon Sekiyu)	T599	100	70	- 2	+ 1.4	◎	
				120	70	- 2	+ 1.9	◎
Albania Grease 3 (Showa Shell Sekiyu)	F585	120	70	- 1	+ 1.1	◎		
		150	70	0	+ 2.0	◎		
		175	70	+ 1	+ 2.4	○		
Albania EP Grease 2 (Showa Shell Sekiyu)	A103	100	70	- 6	+ 0.2	◎		
			500	- 3	- 0.1	◎		
		120	70	- 5	0	△		
			500	0	- 0.2	△		
		150	70	- 4	+ 0.2	✕		
			500	+ 5	+ 2.3	✕		
	A275	100	70	+ 1	- 6.3	○		
Brake fluid	(Glycol ether base) DOT 3 (Nihon Sekiyu)	A727	100	200	-33	+ 70.1	✕	
		T303	100	200	-42	+131.2	✕	
		S728	100	200	- 3	+ 4.0	◎	
		F585	100	200	-35	+ 54.0	✕	
		E309	100	200	- 4	+ 4.2	◎	
		R189	100	200	- 7	+ 11.5	○	
	(Glycol ether base) DOT 5 (Nihon Sekiyu)	A727	100	200	-42	+ 71.5	✕	
		T303	100	200	-40	+126.1	✕	
		S728	100	200	- 4	+ 3.7	◎	
		F585	100	200	-53	+121.0	✕	
		E309	100	200	- 5	+ 3.2	◎	
		R189	100	200	- 9	+ 11.5	○	
	(Silicone oil base) DOT 5 (Sanshin Chemical)	A727	100	200	- 5	+ 5.9	○	
		T303	100	200	- 9	+ 5.3	○	
		S728	100	200	-18	+ 40.1	✕	
		F585	100	200	-17	+ 22.5	✕	
		E309	100	200	- 6	+ 5.2	○	
		R189	100	200	- 4	+ 5.3	○	
	MIL fluid	MIL-S-3136 Type 2	F384	25	70	- 1	+ 0.7	◎
		MIL-S-3136 Type 3	F384	20	72	- 4	+ 1.1	◎
MIL-H-5606 Aerohydraulic Oil HFA (Mobil Sekiyu)		A727	100	70	- 3	+ 7.7	◎	
		A103	80	70	- 1	+ 4.1	◎	
		S728	150	70	-18	+ 83.1	✕	
	F384	150	70	- 2	+ 3.1	◎		

Oil Resistance Data

Sealing Fluid (Manufacturer)		NOK Lip Material	Test Temperature (°C)	Test Duration (h)	Hardnes Change (Durometer A) (points)	Volume Change (%)	Resistance Ratinaerial	
MIL fluid	MIL-O-6081B Aplex M Turbo 201/1010 (Mobil Sekiyu)	F384	100	70	0	+ 0.7	○	
	MIL-L-6082 Grade 1065	F384	200	72	0	+ 2.7	○	
	MIL-L-6086 Type 1	A103	100	70	- 3	+ 6.1	○	
		S728	100	76	-17	+77.5	✕	
		S728	25	70	- 6	+10.3	○	
	MIL-L-6086 Aeroshell Fluid 5L	F384	150	70	0	+ 1.0	○	
		F384	175	70	0	+ 0.4	○	
		MIL-L-7808 Esso Turbo Oil TJ-15 (Esso Sekiyu)	S728	100	70	- 8	+18.1	△
			F384	100	70	- 4	+ 3.5	○
			F384	150	70	- 5	+ 4.9	○
	F384		175	70	- 8	+10.4	△	
	MIL-L-7808 (Aplex S Turbo #256 (Mobil Sekiyu)	F384	200	70	- 9	+11.5	△	
		MIL-L-7808 Esso Turbo Oil #35 (Esso Sekiyu)	S728	120	70	-11	+20.5	○
			S728	150	70	-14	+28.3	△
		MIL-L-23699 Esso Turbo Oil 2380 (Esso Sekiyu)	F384	120	70	- 2	+ 3.8	○
F384			200	72	- 7	+ 7.7	○	
MIL-L-23699 Esso Extra Turbo Oil #274 (Esso Sekiyu)	A727	150	70	-16	+31.4	✕		
	T303	150	70	-11	+27.6	✕		
	S728	150	70	- 8	+12.6	○		
	F384	150	70	- 5	+ 4.6	○		
MIL-L-23699 Mobil Jet Oil II (Mobil Sekiyu)	S728	120	70	- 5	+ 7.2	○		
	F384	120	70	- 2	+ 5.1	○		
Fluorine oil	Daifuroru #20 (Daikin Industries)	S728	100	48	- 2	+ 6.7	○	
	BARIERTA J100 FLUID (NOK Kluber)	A103	70	100	- 4	- 0.8	○	
		A103	70	166	+ 1	- 0.2	○	
		T303	T303	70	100	- 4	+ 0.2	○
			T303	70	166	+ 1	- 0.8	○
		F384	70	200	- 3	0	○	
		F384	70	100	- 3	- 0.2	○	
F384	70	166	+ 1	- 0.5	○			
F384	70	200	- 2	0	○			
Silicone oil	KF96 10cSt (Shin-Etsu Chemical)	S728	100	70	-20	+75.8	✕	
	KF96 10000cSt (Shin-Etsu Chemical)	A103	100	70	+ 7	- 6.3	○	
		A103	120	70	+ 9	- 6.9	△	
S728	120	70	- 4	+ 8.0	△			
Vegetable oil	Castor oil	A103	100	70	- 3	+ 2.1	○	
	Turpentine oil	F384	60	70	- 1	+ 2.8	○	
Water	Distilled water	A727	98	200	+ 5	+ 6.8	○	
		A941	98	200	0	+ 9.5	○	
		A275	98	200	- 2	+ 1.6	○	
		A571	98	200	- 2	+ 5.5	○	
		A368	98	200	- 1	+ 2.4	○	
		A989	98	200	- 6	+ 8.0	○	
		A103	98	200	- 5	+ 5.2	○	
		T303	98	200	-27	+46.8	✕	
		S728	98	200	+ 1	+ 3.4	○	
		S817	98	200	0	+ 1.0	○	
	F585	98	200	+ 1	+ 8.0	△		
	Sea water	A727	40	168	- 1	+ 1.7	○	
A103		20	320	- 3	+ 0.8	○		
T303		40	168	- 5	+21.8	✕		

Oil Resistance Data

Sealing Fluid (Manufacturer)		NOK Lip Material	Test Temperature (°C)	Test Duration (h)	Hardness Change (Durometer A) (points)	Volume Change (%)	Resistance Rating
Water	Sea water	S728	40	168	- 3	+ 0.4	○
		F384	40	168	- 1	+ 0.1	◎
Test oil	ASTM No.1 oil (Nippon Sun Sekiyu)	A727	100	70	+ 1	- 1.7	◎
			120	70	+ 4	- 3.1	○
		A103	80	70	+ 2	- 4.1	◎
			100	70	+ 3	- 4.4	◎
			120	70	+ 4	- 6.4	○
			130	70	+ 5	- 4.9	△
		A104	100	70	+ 3	- 5.6	◎
			130	70	+ 3	- 5.0	△
		A795	100	70	+ 6	- 6.6	◎
		T303	150	70	+ 3	- 2.0	◎
			175	70	+ 6	- 3.2	△
		S728	150	70	+ 1	+ 3.5	◎
			175	70	- 2	+ 7.0	△
			200	70	- 8	+ 6.2	×
		F384	150	70	0	- 0.1	◎
		175	70	+ 1	+ 0.2	◎	
	ASTM No.3 oil (Nippon Sun Sekiyu)	A727	100	70	- 6	+ 10.0	○
			120	70	- 9	+ 10.1	△
		A103	80	70	- 8	+ 10.3	○
			100	70	- 9	+ 11.7	○
			120	70	- 7	+ 9.5	○
			130	70	- 9	+ 10.8	△
		A104	100	70	- 8	+ 8.7	○
			130	70	- 9	+ 10.0	△
		A795	100	70	0	+ 2.5	◎
		T303	150	70	- 4	+ 9.5	○
			175	70	- 1	+ 11.1	△
		S728	150	70	- 7	+ 27.5	△
			175	70	- 11	+ 40.0	×
			200	70	- 21	+ 47.5	×
		F384	150	70	0	+ 0.9	◎
		175	70	+ 1	+ 2.3	◎	
	ASTM flame-retardant oil B	S728	25	70	Immeasurable	+ 215.0	×
F384		25	70	- 1	+ 0.7	◎	
ASTM flame-retardant oil C	F384	20	72	- 4	+ 1.1	◎	
ASTM service fluid No. 101	F384	200	70	- 6	+ 7.8	○	

Chemical Resistance Data

Note: Refer to page J-6 before use.

Sealing Fluid	NOK Lip Material	Test Temperature (°C)	Test Duration (h)	Hardness Change (Durometer A) (points)	Volume Change (%)	Resistance Rating
Inorganic acids <small>(see note)</small>	10% hydrochloric acid solution					
	A727	40	168	- 5	+ 14.8	○
	T303	40	168	- 6	+ 8.6	○
	S728	40	168	- 3	+ 8.1	○
	F384	40	168	- 7	+ 8.1	○
	30% sulfuric acid solution					
	A727	40	168	—	+ 0.3	△
	T303	40	168	—	+ 3.7	△
	S728	40	168	—	+ 0.3	×
	F384	40	168	—	+ 15.0	△
	Sulfurous acid					
	A727	40	168	-15	+157.0	×
	T303	40	168	-21	+100.0	×
	S728	40	168	- 5	+ 43.7	×
	F384	40	168	-10	+ 7.6	△
	10% nitric acid solution					
	A727	40	168	+14	+ 31.0	×
	T303	40	168	-19	+ 40.0	×
	S728	40	168	+ 2	+ 21.2	×
	F384	40	168	-12	+ 17.8	△
	Chromic acid (saturated aqueous solution)					
	A727	40	168	Immeasurable	Immeasurable	×
	T303	40	168	- 5	+ 18.0	△
	S728	40	168	-10	+ 7.6	△
	F384	40	168	- 6	+ 6.9	○
	Silicic acid (saturated aqueous solution)					
	A727	40	168	- 1	+ 3.1	◎
	T303	40	168	-10	+ 35.6	×
S728	40	168	+ 3	+ 0.9	◎	
F384	40	168	+ 1	+ 0.3	◎	
85% phosphoric acid solution						
A727	40	168	- 1	+ 0.5	◎	
T303	40	168	0	- 0.2	◎	
S728	40	168	+ 1	+ 0.3	◎	
F384	40	168	- 2	+ 7.6	○	
Organic acids <small>(see note)</small>	Glacial acetic acid					
	A727	40	168	—	+ 32.6	×
	T303	40	168	—	+166.0	×
	S728	40	168	—	+ 19.0	△
	F384	40	168	—	+ 45.3	×
	10% acetic acid solution					
	A727	40	168	-13	+122.0	×
	T303	40	168	-10	+ 50.5	×
	S728	40	168	- 1	+ 4.7	×
	F384	40	168	0	+ 4.5	◎
	40% acetic acid solution					
	A727	40	168	-11	+ 72.0	×
	T303	40	168	-10	+ 61.4	×
	S728	40	168	- 1	+ 7.7	×
	F384	40	168	-14	+ 17.4	△
	70% acetic acid solution					
	A727	40	168	—	+ 81.0	×
	T303	40	168	—	+ 64.2	×
	S728	40	168	—	+ 16.8	×
	30% methanoic acid solution					
A727	40	168	-12	+114.0	×	
T303	40	168	-10	+ 53.2	×	
S728	40	168	- 1	+ 9.3	△	
F384	40	168	- 5	+ 7.6	○	
30% mono-chloroacetic acid solution						
A727	40	168	-11	+ 25.2	×	
T303	40	168	- 6	+ 42.5	×	
S728	40	168	- 4	+ 29.3	△	
F384	40	168	-11	+ 11.3	△	
Oleic acid						
A727	40	168	- 3	+ 22.4	△	

Chemical Resistance Data

Note: Refer to page J-6 before use.

Sealing Fluid		NOK Lip Material	Test Temperature (°C)	Test Duration (h)	Hardnes Change (Durometer A) (points)	Volume Change (%)	Resistance Ratio
Organic acids (see note)	Oleic acid	T303	40	168	- 4	+ 15.8	△
		S728	40	168	0	+ 14.8	○
		F384	40	168	0	+ 20.0	○
	Oxalic acid	A727	40	168	+ 2	+ 1.9	◎
		T303	40	168	- 9	+ 30.0	×
		S728	40	168	- 1	+ 0.5	◎
		F384	40	168	0	+ 25.3	△
	Maleic acid	A727	40	168	-10	+ 90.3	×
		T303	40	168	-10	+ 41.7	×
		S728	40	168	- 3	+ 11.2	○
		F384	40	168	- 8	+ 6.4	○
	Tannic acid (saturated solution)	A727	40	168	+ 3	+ 3.6	◎
		T303	40	168	- 2	+ 43.9	×
		S728	40	168	+ 5	+ 0.6	◎
		F384	40	168	+ 5	+ 1.3	◎
Gallic acid	A727	40	168	- 7	+ 17.5	△	
	T303	40	168	-18	+ 48.9	×	
	S728	40	168	- 3	+ 1.1	◎	
	F384	40	168	+ 5	+ 2.9	◎	
Alkalis (see note)	10% ammonia aqueous solution	A727	40	168	- 3	+ 5.9	○
		T303	40	168	-16	+ 86.2	×
		S728	40	168	+ 9	+ 1.3	×
		F384	40	168	- 4	+ 10.6	○
	28% ammonia aqueous solution	A727	40	168	- 5	+ 6.1	○
		T303	40	168	-29	+118.0	×
		S728	40	168	+ 3	+ 3.0	×
		F384	40	168	-10	+ 30.1	×
	10% sodium hydroxide solution (saturated solution)	A727	40	168	+ 3	+ 0.5	◎
		T303	40	168	-10	+ 1.5	△
		S728	40	168	- 3	- 7.1	×
		F384	40	168	-10	- 9.0	×
	40% sodium hydroxide solution (saturated solution)	A727	40	168	+ 1	- 0.9	◎
		T303	40	168	-12	+ 18.9	×
		S728	40	168	- 3	- 10.6	×
		F384	40	168	- 5	- 3.7	×
	10% potassium hydroxide solution (saturated solution)	A727	40	168	- 1	+ 0.3	◎
		T303	40	168	-15	+ 31.5	×
		S728	40	168	- 1	- 10.0	×
		F384	40	168	-20	- 8.0	×
	40% potassium hydroxide solution (saturated solution)	A727	40	168	- 1	+ 0.4	◎
		T303	40	168	Immeasurable	Immeasurable	×
		S728	40	168	+ 3	- 3.3	×
		F384	40	168	+ 8	+ 4.4	△
Aluminum hydroxide (saturated solution)	A727	40	168	- 1	+ 2.3	◎	
	T303	40	168	- 7	+38.5	×	
	S728	40	168	+ 4	+ 1.0	◎	
	F384	40	168	- 2	+ 1.8	◎	
Barium hydroxide (saturated solution)	A727	40	168	- 1	+ 1.3	◎	
	T303	40	168	- 5	+16.2	×	
	S728	40	168	+ 2	- 0.6	◎	
	F384	40	168	- 2	+ 1.2	◎	
Calcium hydroxide (saturated solution)	A727	40	168	+ 1	+ 1.9	◎	

Chemical Resistance Data

Note: Refer to page J-6 before use.

Sealing Fluid		NOK Lip Material	Test Temperature (°C)	Test Duration (h)	Hardness Change (Durometer A) (points)	Volume Change (%)	Resistance Rating	
Alkalis (see note)	Calcium hydroxide (saturated solution)	T303	40	168	- 4	+30.2	✗	
		S728	40	168	+ 5	+ 1.1	○	
		F384	40	168	+ 4	+ 1.6	○	
	Magnesium hydroxide (saturated solution)	A727	40	168	+ 1	+ 1.9	○	
		T303	40	168	- 5	+39.5	✗	
		S728	40	168	+ 3	+ 2.1	○	
		F384	40	168	+ 1	+ 2.5	○	
	Inorganic salts (see note)	Cupric chloride (saturated solution)	A727	40	168	- 2	+14.0	○
			T303	40	168	+ 5	+ 4.1	○
S728			40	168	+ 6	+ 0.1	○	
F384			40	168	+ 2	+10.0	○	
Sodium chloride (saturated solution)		A727	40	168	+ 1	0	○	
		T303	40	168	+ 5	+ 2.9	○	
		S728	40	168	- 1	+ 0.4	○	
		F384	40	168	- 2	+ 0.6	○	
Barium chloride (saturated solution)		A727	40	168	0	0	○	
		T303	40	168	- 1	+ 6.0	○	
		S728	40	168	+ 2	- 1.1	○	
		F384	40	168	- 5	+ 0.9	○	
Magnesium chloride (saturated solution)		A727	40	168	0	+ 1.0	○	
		T303	40	168	0	+ 7.1	○	
		S728	40	168	+ 2	- 0.3	○	
		F384	40	168	0	- 0.8	○	
Potassium chlorate (saturated solution)		A727	40	168	+ 1	+ 1.6	○	
		T303	40	168	+ 4	+12.7	○	
		S728	40	168	+ 1	- 0.1	○	
		F384	40	168	+ 1	+ 0.1	○	
Potassium Permanganate (saturated solution)		A727	40	168	Immeasurable	Immeasurable	✗	
		T303	40	168	-10	+46.3	✗	
		S728	40	168	+ 2	- 0.2	○	
		F384	40	168	- 6	+ 1.7	○	
Potassium chromate (saturated solution)		A727	40	168	- 1	+ 1.0	○	
		T303	40	168	- 2	+ 6.9	○	
		S728	40	168	+ 2	- 0.3	○	
		F384	40	168	+ 2	+ 2.3	○	
Sodium chromate (saturated solution)		A727	40	168	- 5	+ 0.5	○	
		T303	40	168	- 5	+ 4.6	✗	
		S728	40	168	- 1	- 0.4	○	
		F384	40	168	- 1	- 2.0	○	
Lead acetate (saturated solution)		A727	40	168	-10	+20.6	✗	
		T303	40	168	- 7	+12.4	△	
		S728	40	168	- 3	+ 1.4	○	
		F384	40	168	- 5	+ 0.7	○	
Ammonium bicarbonate (saturated solution)	A727	40	168	- 6	+ 1.0	○		

Chemical Resistance Data

Note: Refer to page J-6 before use.

Sealing Fluid	NOK Lip Material	Test Temperature (°C)	Test Duration (h)	Hardness Change (Durometer A) (points)	Volume Change (%)	Resistance Rating
Inorganic salts (see note)	Ammonium bicarbonate (saturated solution)					
	T303	40	168	-13	+22.2	×
	S728	40	168	-1	+5.0	○
	F384	40	168	-5	+8.4	○
	Ammonium nitrate (saturated solution)					
	A727	40	168	0	-0.3	○
	T303	40	168	0	+2.1	○
	S728	40	168	+2	-0.2	○
	F384	40	168	+2	-0.3	○
	Silver nitrate (saturated solution)					
	A727	40	168	-60	Immeasurable	×
	T303	40	168	-8	+7.6	○
S728	40	168	-3	+0.7	○	
F384	40	168	+5	+1.4	○	
Lead nitrate (saturated solution)						
A727	40	168	-4	+5.5	○	
T303	40	168	-7	+14.4	△	
S728	40	168	-1	+0.5	○	
F384	40	168	+1	+1.1	○	
Sodium nitrate (saturated solution)						
A727	40	168	-5	+0.5	○	
T303	40	168	-3	+3.7	○	
S728	40	168	-1	+0.2	○	
F384	40	168	-3	+0.7	○	
Ammonium carbonate (saturated solution)						
A727	40	168	+4	+3.0	○	
T303	40	168	-14	+57.4	×	
S728	40	168	+8	+4.1	○	
F384	40	168	+4	+8.2	○	
Potassium carbonate (saturated solution)						
A727	40	168	-2	+0.9	○	
T303	40	168	0	+8.8	○	
S728	40	168	-1	-0.4	○	
F384	40	168	0	+0.5	○	
Sodium nitrite (saturated solution)						
A727	40	168	-1	+0.6	○	
T303	40	168	-4	+3.5	△	
S728	40	168	+2	+0.3	○	
F384	40	168	-5	+0.7	○	
Sodium sulfite (saturated solution)						
A727	40	168	-2	+0.5	○	
T303	40	168	+2	+4.4	△	
S728	40	168	+2	+0.2	○	
F384	40	168	0	+1.2	○	
Ammonium chloride (saturated solution)						
A727	40	168	+1	+0.7	○	
T303	40	168	-2	+5.1	○	
S728	40	168	+6	+0.1	○	
F384	40	168	0	+1.2	○	
Zinc chloride (saturated solution)						
A727	40	168	-1	+12.8	○	
T303	40	168	+10	+6.0	×	
S728	40	168	+6	-0.5	○	
F384	40	168	+5	+0.7	○	
Potassium chloride (saturated solution)						
A727	40	168	0	0	○	
T303	40	168	-2	+4.6	○	
S728	40	168	+1	+1.5	○	
F384	40	168	+1	+0.5	○	
Calcium chloride (saturated solution)						
A727	40	168	-1	-0.5	○	
T303	40	168	+1	+0.5	○	
S728	40	168	+2	-0.1	○	
F384	40	168	-1	-0.4	○	
Stannic chloride						
A727	40	168	-6	+22.6	×	

Chemical Resistance Data

Note: Refer to page J-6 before use.

Sealing Fluid	NOK Lip Material	Test Temperature (°C)	Test Duration (h)	Hardness Change (Durometer A) (points)	Volume Change (%)	Resistance Rating
Stannic chloride	T303	40	168	- 8	+ 13.9	△
	S728	40	168	- 1	+ 1.5	○
	F384	40	168	- 11	+ 9.0	×
Mercuric chloride (saturated solution)	A727	40	168	+ 7	+ 27.4	×
	T303	40	168	- 16	+ 44.7	×
	S728	40	168	- 1	+ 2.8	○
	F384	40	168	- 2	+ 1.6	○
Ferric chloride (saturated solution)	A727	40	168	- 6	+ 41.0	×
	T303	40	168	- 5	+ 41.6	×
	S728	40	168	+ 5	- 0.2	○
	F384	40	168	- 5	- 1.9	○
Sodium carbonate (saturated solution)	A727	40	168	- 1	+ 0.2	○
	T303	40	168	- 10	+ 7.3	△
	S728	40	168	0	- 0.7	○
	F384	40	168	+ 1	- 3.2	○
Alum (potassium alum) (saturated solution)	A727	40	168	- 2	+ 2.3	○
	T303	40	168	- 10	+ 22.9	×
	S728	40	168	+ 5	0	○
	F384	40	168	- 2	+ 1.4	○
Potassium iodide (saturated solution)	A727	40	168	- 1	+ 1.0	○
	T303	40	168	- 2	- 3.5	○
	S728	40	168	+ 1	+ 0.8	○
	F384	40	168	+ 4	- 0.5	○
Sodium sulfide (saturated solution)	A727	40	168	- 1	0	○
	T303	40	168	- 18	Immeasurable	×
	S728	40	168	+ 2	- 1.5	○
	F384	40	168	- 17	+ 13.9	×
Zinc sulfate (saturated solution)	A727	40	168	0	+ 1.1	○
	T303	40	168	- 1	+ 9.8	○
	S728	40	168	+ 2	- 0.3	○
	F384	40	168	- 3	+ 0.6	○
Ammonium sulfate (saturated solution)	A727	40	168	- 8	- 0.3	△
	T303	40	168	+ 8	+ 2.7	△
	S728	40	168	+ 4	+ 0.8	○
	F384	40	168	- 5	+ 0.1	○
Potassium sulfate (saturated solution)	A727	40	168	+ 7	+ 1.9	△
	T303	40	168	- 10	+ 9.7	△
	S728	40	168	+ 2	+ 0.2	○
	F384	40	168	- 2	+ 2.0	○
Calcium sulfate (saturated solution) (gypsum)	A727	40	168	- 1	+ 2.5	○
	T303	40	168	+ 8	+ 39.8	×
	S728	40	168	+ 4	+ 0.7	○
	F384	40	168	+ 1	+ 1.3	○
Ferrous sulfate (saturated solution)	A727	40	168	+ 5	+ 1.7	○
	T303	40	168	- 5	+ 12.0	△
	S728	40	168	- 1	+ 2.1	○
	F384	40	168	- 3	+ 0.9	○
Ferric sulfate (saturated solution)	A727	40	168	- 2	+ 2.5	○
	T303	40	168	- 13	+ 5.9	×
	S728	40	168	- 5	- 0.4	○
	F384	40	168	- 6	+ 8.3	○
Copper sulfate (saturated solution)	A727	40	168	- 3	+ 2.3	○

Inorganic salts (see note)

Chemical Resistance Data

Note: Refer to page J-6 before use.

Sealing Fluid		NOK Lip Material	Test Temperature (°C)	Test Duration (h)	Hardness Change (Durometer A) (points)	Volume Change (%)	Resistance Rating
Inorganic salts (see note)	Copper sulfate (saturated solution)	T303	40	168	-16	+23.1	×
		S728	40	168	-5	+0.3	○
		F384	40	168	+7	+2.1	×
	Sodium sulfate (saturated solution)	A727	40	168	+5	+1.0	○
		T303	40	168	-7	+12.4	△
		S728	40	168	+2	+0.1	○
		F384	40	168	+5	+0.4	○
	Nickel sulfate (saturated solution)	A727	40	168	—	+0.6	○
		T303	40	168	—	+16.7	△
		S728	40	168	—	+30.0	×
		F384	40	168	—	+0.8	○
	Magnesium sulfate (saturated solution)	A727	40	168	—	+1.3	○
		T303	40	168	—	+17.8	△
		S728	40	168	—	+0.9	○
		F384	40	168	—	+1.7	○
	Disodium hydrogenphosphate	A727	40	168	-3	+1.5	○
T303		40	168	-9	+12.4	△	
S728		40	168	+1	0	○	
F384		40	168	-6	+0.6	×	
Alcohols	Methyl alcohol	A727	40	168	-8	+4.8	○
		T303	40	168	-32	+46.2	×
		S728	40	168	-3	+2.0	○
		F384	40	168	-18	+17.9	△
	Ethyl alcohol	A727	40	168	-10	+6.6	○
		T303	40	168	-29	+50.6	×
		S728	40	168	-8	+12.6	○
		F384	40	168	-13	+9.8	○
	Isopropyl alcohol	A727	40	168	-8	+7.4	○
		T303	40	168	-18	+57.7	×
		S728	40	168	-10	+11.4	△
		F384	40	168	-8	+4.8	○
	Butyl alcohol	A727	40	168	-18	+12.9	△
		T303	40	168	-12	+58.0	×
		S728	40	168	-12	+20.2	○
		F384	40	168	-1	+2.7	○
	Isoamyl alcohol	A727	40	168	-4	-0.3	○
		T303	40	168	-23	+47.3	×
		S728	40	168	-12	+20.8	△
		F384	40	168	-5	+1.9	○
	Ethylene glycol	A727	40	168	-4	-1.1	○
		T303	40	168	-20	+18.1	×
		S728	40	168	0	+0.9	○
		F384	40	168	0	+0.3	○
Glycerin	A727	40	168	0	+0.5	○	
	T303	40	168	-5	+2.9	○	
	S728	40	168	0	+0.5	○	
	F384	40	168	+1	-0.8	○	
Aldehydes/ketones	Formalin	A727	40	168	-8	+7.1	○
		T303	40	168	-16	+41.3	×
		S728	40	168	-3	+1.0	○
		F384	40	168	-4	-0.4	○
	Acetaldehyde	A727	40	168	-17	+66.1	×

Chemical Resistance Data

Sealing Fluid		NOK Lip Material	Test Temperature (°C)	Test Duration (h)	Hardness Change (Durometer A) (points)	Volume Change (%)	Resistance Rating	
Aldehydes/ketones	Acetaldehyde	T303	40	168	-31	+ 58.1	×	
		S728	40	168	- 8	+ 5.0	○	
		F384	40	168	-52	+ 85.8	×	
	Methyl ethyl ketone	A727	40	168	-24	+102.0	×	
		T303	40	168	-27	+139.0	×	
		S728	40	168	-12	+ 20.0	△	
F384	40	168	測定不能	測定不能	×			
Esters	Methyl acetate	A727	40	168	-29	+ 59.3	×	
		T303	40	168	-39	+210.0	×	
		S728	40	168	- 9	+ 13.3	○	
		F384	40	168	—	+203	×	
	Ethyl acetate	A727	40	168	-19	+ 81.1	×	
		T303	40	168	-25	+102.0	×	
		S728	40	168	-12	+ 21.5	△	
		F384	40	168	測定不能	測定不能	×	
	Butyl acetate	A727	40	168	-26	+123.0	×	
		T303	40	168	-32	+129.0	×	
		S728	40	168	-23	+105.0	×	
		F384	40	168	測定不能	測定不能	×	
	Isoamyl acetate	A727	40	168	-19	+ 79.8	×	
		T303	40	168	-27	+165.0	×	
		S728	40	168	-19	+ 91.9	×	
		F384	40	168	—	+104.0	×	
	Dibutyl phthalate	A727	40	168	-24	+139.0	×	
		T303	40	168	-29	+154.0	×	
		S728	40	168	- 1	+ 3.4	○	
		F384	40	168	-26	+ 60.8	×	
	Hydrocarbons	Isooctane	A727	40	168	- 7	+ 2.6	△
			T303	40	168	- 8	+ 8.1	△
			S728	40	168	-16	+ 77.7	×
			F384	40	168	- 3	+ 8.4	○
Liquid paraffin		A727	40	168	- 1	+ 0.7	◎	
		T303	40	168	- 5	+ 2.7	◎	
		S728	40	168	0	+ 4.6	◎	
		F384	40	168	- 2	+ 3.5	◎	
Kerosene		A727	40	168	- 9	+ 7.6	△	
		T303	40	168	- 5	+ 8.9	△	
		S728	40	168	-22	+107.0	×	
		F384	40	168	- 1	+ 1.4	◎	
1.2-dichloroethane		A727	40	168	—	+243.0	×	
		T303	40	168	—	+310.0	×	
		S728	40	168	—	+ 36.5	×	
		F384	40	168	—	+ 55.3	×	
Trichlene (trichloroethylene)		A727	40	168	-21	+132.0	×	
		T303	40	168	-33	+222.0	×	
		S728	40	168	-19	+ 98.5	×	
		F384	40	168	-47	+ 70.6	×	
1.1.1-trichloroethane		A727	60	48	-16	+134.0	×	
		S728	60	48	-25	+ 46.3	×	
		F384	60	48	-12	+110.0	×	

Chemical Resistance Data

Sealing Fluid		NOK Lip Material	Test Temperature (°C)	Test Duration (h)	Hardness Change (Durometer A) (points)	Volume Change (%)	Resistance Rating
Hydrocarbons/Halogenated hydrocarbons	Benzene	A727	40	168	-29	+160.0	×
		T303	40	168	-27	+277.0	×
		S728	40	168	-22	+120.0	×
		F384	40	168	-36	+ 66.3	×
	Toluene	A727	40	168	-23	+137.0	×
		T303	40	168	-37	+241.0	×
		S728	40	168	-22	+130.0	×
		F384	40	168	-33	+ 64.8	×
	Methaxylene	A727	40	168	-14	+ 84.8	×
		T303	40	168	-25	+157.0	×
		S728	40	168	-16	+ 80.0	×
		F384	40	168	-26	+ 48.8	×
	Ethylbenzene	A727	40	168	-21	+ 46.1	×
		T303	40	168	-30	+114.0	×
		S728	40	168	-19	+ 66.7	×
		F384	40	168	-20	+ 67.5	×
	Styrene	A727	40	168	-27	+176.0	×
		T303	40	168	-39	+253.0	×
		S728	40	168	-22	+177.0	×
		F384	40	168	-31	+ 37.5	×
	Monochlorobenzene	A727	40	168	-23	+213.0	×
		T303	40	168	-39	+278.0	×
		S728	40	168	—	+120.0	×
		F384	40	168	-25	+ 77.8	×
	Trichlorobenzene	A727	40	168	-16	+165.0	×
		T303	40	168	-31	+220.0	×
		S728	40	168	-17	+ 25.3	×
		F384	40	168	-16	+ 18.6	×
Bromobenzene	A727	40	168	-24	+206.0	×	
	T303	40	168	-32	+250.0	×	
	S728	40	168	-17	+ 57.7	×	
	F384	40	168	-21	+ 25.7	×	
Miscellaneous	Dioxane	A727	40	168	-28	+164.0	×
		T303	40	168	-24	+168.0	×
		S728	40	168	- 6	+ 8.3	○
		F384	40	168	Immeasurable	Immeasurable	×
	Phenyl ether (diphynyloxyde)	A727	40	168	-15	+ 15.1	×
		T303	40	168	-25	+ 73.5	×
		S728	40	168	- 7	+ 10.0	○
		F384	40	168	+ 1	+ 8.6	○
	Phenol	A727	40	168	-35	+113.0	×
		T303	40	168	-32	+150.0	×
		S728	40	168	- 5	+ 4.0	◎
		F384	40	168	- 6	+ 19.1	△
	Cresol	A727	40	168	Immeasurable	Immeasurable	×
		T303	40	168	Immeasurable	Immeasurable	×
		S728	40	168	0	+ 0.8	◎
		F384	40	168	- 3	+ 3.4	△
	Aniline	A727	40	168	-29	+217.0	×
		T303	40	168	-46	+290.0	×
		S728	40	168	0	+ 2.3	◎
		F384	40	168	- 5	+147.0	×

Chemical Resistance Data

Sealing Fluid	NOK Lip Material	Test Temperature (°C)	Test Duration (h)	Hardness Change (Durometer A) (points)	Volume Change (%)	Resistance Rating	
Miscellaneous	Nitrobenzene	A727	40	168	-25	+199.0	×
		T303	40	168	-42	+269.0	×
		S728	40	168	0	+ 4.0	○
		F384	40	168	-50	+103.0	×
	Urea (saturated solution)	A727	40	168	+ 2	- 0.8	○
		T303	40	168	- 9	+ 9.2	△
		S728	40	168	+ 1	+ 0.3	○
		F384	40	168	- 2	+ 1.2	○
	Carbon disulfide	A727	40	168	-20	+ 47.8	×
		T303	40	168	-11	+ 47.7	×
		S728	40	168	0	+ 3.7	○
		F384	40	168	-12	+ 12.3	×
	Hydrogen peroxide water	A727	40	168	- 3	+ 10.5	△
		T303	40	168	-53	+ 78.2	×
		S728	40	168	- 1	+ 1.7	○
		F384	40	168	0	+ 0.9	○
	Chlorine water	A727	40	168	- 4	+ 3.1	○
		T303	40	168	- 8	+ 54.3	×
		S728	40	168	- 3	+ 19.5	○
		F384	40	168	- 6	+ 3.0	○
	Urea water	A727	40	168	+ 3	+ 21.7	×
		T303	40	168	-40	+394.0	×
		S728	40	168	+ 1	+ 22.6	△
		F384	40	168	0	+ 2.5	○

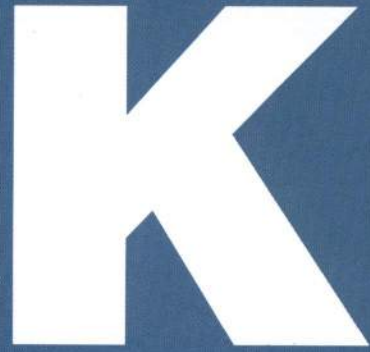

Reference Data

- Linear Shaft Velocity Quick Reference — K-2
- A Comparison of NOK Type
and ISO, JIS, and JASO Type Oil Seals — K-3
- Shaft Sizes and Tolerance — K-4
- Bore Sizes and Tolerance — K-5
- Basic Tolerances for Large Applications — K-6
- Conversion Table for SI Units — K-7
- Surface Roughness vs Machining Method — K-7
- Viscosity Conversion Table — K-8
- Temperature Conversion Table — K-9
- KluBer Lubricants for Seal Use — K-10
- NOK Products List — K-12

K

K. REFERENCE DATA

Linear Shaft Velocity Quick Reference Table

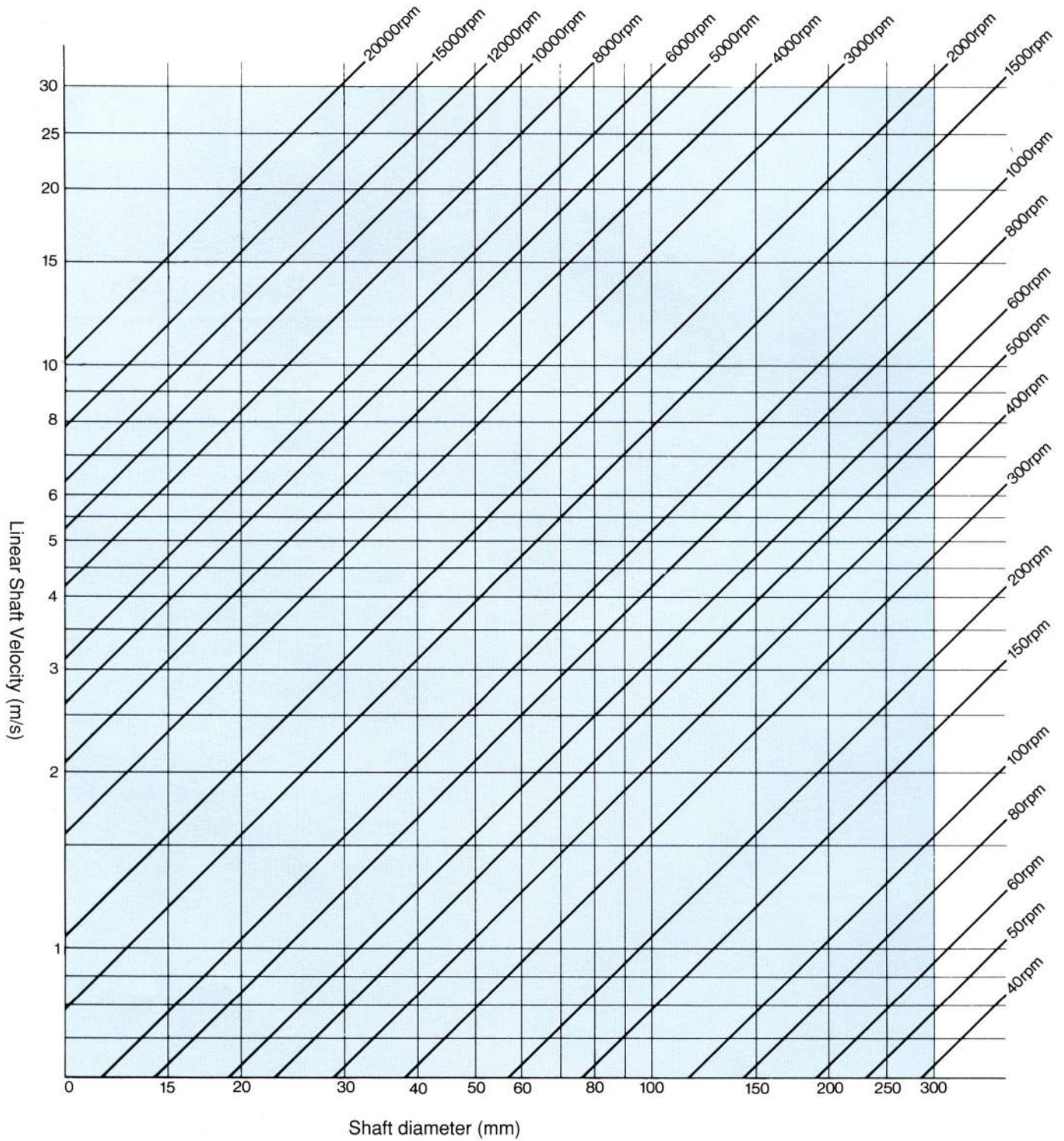

K

A Comparison of NOK Type and ISO, JIS, and JASO Type Oil Seals

Standard Profile/shape	NOK	ISO	JIS	JASO
	SC	TYPE 1	TYPE 1	S
	SB	TYPE 2	TYPE 2	SM
	TC	TYPE 4	TYPE 4	D
	TB	TYPE 5	TYPE 5	DM
	VC	—	—	G
	VB	—	—	GM
	KC	—	—	P
	KB	—	—	PM

K

Basic Tolerances for Large Applications (JIS B 0401)

Unit: 0.001 mm

Nominal Size Size Group (mm)		Shaft Tolerances	Bore Tolerances		
		h9	H7	H8	H12
Over	Up to	Upper tolerance Lower tolerance			
500	630	$\begin{matrix} 0 \\ -175 \end{matrix}$	$\begin{matrix} + 70 \\ 0 \end{matrix}$	$\begin{matrix} + 110 \\ 0 \end{matrix}$	$\begin{matrix} + 700 \\ 0 \end{matrix}$
630	800	$\begin{matrix} 0 \\ -200 \end{matrix}$	$\begin{matrix} + 80 \\ 0 \end{matrix}$	$\begin{matrix} + 125 \\ 0 \end{matrix}$	$\begin{matrix} + 800 \\ 0 \end{matrix}$
800	1000	$\begin{matrix} 0 \\ -230 \end{matrix}$	$\begin{matrix} + 90 \\ 0 \end{matrix}$	$\begin{matrix} + 140 \\ 0 \end{matrix}$	$\begin{matrix} + 900 \\ 0 \end{matrix}$
1000	1250	$\begin{matrix} 0 \\ -260 \end{matrix}$	$\begin{matrix} + 105 \\ 0 \end{matrix}$	$\begin{matrix} + 165 \\ 0 \end{matrix}$	$\begin{matrix} + 1050 \\ 0 \end{matrix}$
1250	1600	$\begin{matrix} 0 \\ -310 \end{matrix}$	$\begin{matrix} + 125 \\ 0 \end{matrix}$	$\begin{matrix} + 195 \\ 0 \end{matrix}$	$\begin{matrix} + 1250 \\ 0 \end{matrix}$
1600	2000	$\begin{matrix} 0 \\ -370 \end{matrix}$	$\begin{matrix} + 150 \\ 0 \end{matrix}$	$\begin{matrix} + 230 \\ 0 \end{matrix}$	$\begin{matrix} + 1500 \\ 0 \end{matrix}$
2000	2500	$\begin{matrix} 0 \\ -440 \end{matrix}$	$\begin{matrix} + 175 \\ 0 \end{matrix}$	$\begin{matrix} + 280 \\ 0 \end{matrix}$	$\begin{matrix} + 1750 \\ 0 \end{matrix}$
2500	3150	$\begin{matrix} 0 \\ -540 \end{matrix}$	$\begin{matrix} + 210 \\ 0 \end{matrix}$	$\begin{matrix} + 330 \\ 0 \end{matrix}$	$\begin{matrix} + 2100 \\ 0 \end{matrix}$

Conversion Table for SI Units

The enclosed sections show the SI unit conversions.

Force	N	dyn	kgf
	1	1×10^5	$1.019\ 72 \times 10^{-1}$
	1×10^{-5}	1	$1.019\ 72 \times 10^{-6}$
	9.806\ 65	9.80665×10^5	1

Viscosity	Pa·s	cp	P
	1	1×10^3	1×10
	1×10^{-3}	1	1×10^{-2}
	1×10^{-1}	1×10^2	1

Note: $1\text{P} = 1\text{dyn}\cdot\text{s}/\text{cm}^2 = 1\text{g}/\text{cm}\cdot\text{s}$, $1\text{Pa}\cdot\text{s} = 1\text{N}\cdot\text{s}/\text{m}^2$, $1\text{cP} = 1\text{mPa}\cdot\text{s}$

Pressure	Pa	kPa	MPa	bar	kgf/cm ²	atm	mmH ₂ O	mmHg or Torr
	1	1×10^{-3}	1×10^{-6}	1×10^{-5}	$1.019\ 72 \times 10^{-5}$	$9.869\ 23 \times 10^{-6}$	$1.019\ 72 \times 10^{-1}$	$7.500\ 62 \times 10^3$
	1×10^3	1	1×10^{-3}	1×10^{-2}	$1.019\ 72 \times 10^{-2}$	$9.869\ 23 \times 10^{-3}$	$1.019\ 72 \times 10^2$	7.500\ 62
	1×10^6	1×10^3	1	1×10	$1.019\ 72 \times 10$	9.869\ 23	$1.019\ 72 \times 10^5$	$7.500\ 62 \times 10^3$
	1×10^9	1×10^2	1×10^{-1}	1	1.019\ 72	$9.869\ 23 \times 10^{-1}$	$1.019\ 72 \times 10^4$	$7.500\ 62 \times 10^2$
	$9.806\ 65 \times 10^4$	$9.806\ 65 \times 10$	$9.806\ 65 \times 10^{-2}$	$9.806\ 65 \times 10^{-1}$	1	$9.678\ 41 \times 10^{-1}$	1×10^4	$7.355\ 59 \times 10^2$
	$1.013\ 25 \times 10^5$	$1.013\ 25 \times 10^2$	$1.013\ 25 \times 10^{-1}$	1.013\ 25	1.033\ 23	1	$1.033\ 23 \times 10^4$	$7.600\ 00 \times 10^2$
	9.806\ 65	$9.806\ 65 \times 10^{-3}$	$9.806\ 65 \times 10^{-6}$	$9.806\ 65 \times 10^{-5}$	1×10^{-4}	$9.678\ 41 \times 10^{-5}$	1	$7.355\ 59 \times 10^{-2}$
	$1.333\ 22 \times 10^2$	$1.333\ 22 \times 10^{-1}$	$1.333\ 22 \times 10^{-4}$	$1.333\ 22 \times 10^{-3}$	$1.359\ 51 \times 10^{-3}$	$1.315\ 79 \times 10^{-3}$	$1.359\ 51 \times 10$	1

Note: $1\text{Pa} = 1\text{N}/\text{m}^2$

Stress	Pa or N/m ²	MPa or N/mm ²	kgf	kgf/cm ²
	1	1×10^{-6}	$1.019\ 72 \times 10^{-7}$	$1.019\ 72 \times 10^{-5}$
	1×10^6	1	$1.019\ 72 \times 10^{-1}$	$1.019\ 72 \times 10$
	$9.806\ 65 \times 10^6$	9.806\ 65	1	1×10^2
	$9.806\ 65 \times 10^4$	$9.806\ 65 \times 10^{-2}$	1×10^{-2}	1

Note: $1\text{Pa} = 1\text{N}/\text{m}^2$, $1\text{MPa} = 1\text{N}/\text{mm}^2$

Dynamic viscosity	m ² /s	cSt	St
	1	1×10^6	1×10^4
	1×10^{-6}	1	1×10^2
	1×10^{-4}	1×10^2	1

Note: $1\text{St} = 1\text{cm}^2/\text{s}$, $1\text{cSt} = 1\text{mm}^2/\text{s}$

Hardness Conversion

Approximate conversion value for Rockwell C hardness of steel ASTM					
Rockwell C Scale Hardness	Vickers Hardness	Brinell Hardness 10mm spherical load 300 kg Standard ball	Rockwell Hardness B scale 100 kg load 1/16 in. diameter ball	Shore Hardness	Rockwell C Scale Hardness
68	940	—	—	97	68
67	900	—	—	95	67
66	865	—	—	92	66
65	832	—	—	91	65
64	800	—	—	88	64
63	772	—	—	87	63
62	746	—	—	85	62
61	720	—	—	83	61
60	697	—	—	81	60
59	674	—	—	80	59
58	653	—	—	78	58
57	633	—	—	76	57
56	613	—	—	75	56
55	595	—	—	74	55
54	577	—	—	72	54
53	560	—	—	71	53
52	544	500	—	69	52
51	528	487	—	68	51
50	513	475	—	67	50
49	498	464	—	66	49
48	484	451	—	64	48
47	471	442	—	63	47
46	458	432	—	62	46
45	446	421	—	60	45
44	434	409	—	58	44
43	423	400	—	57	43
42	412	390	—	56	42
41	402	381	—	55	41
40	392	371	—	54	40
39	382	362	—	52	39
38	372	358	—	51	38
37	363	344	—	50	37
36	354	336	(109.0)	49	36
35	345	327	(108.5)	48	35
34	336	319	(108.0)	47	34
33	327	311	(107.5)	46	33
32	318	301	(107.0)	44	32
31	310	294	(106.0)	43	31
30	302	286	(105.5)	42	30
29	294	279	(104.5)	41	29
28	286	271	(104.0)	41	28
27	279	264	(103.0)	40	27
26	272	258	(102.5)	38	26
25	266	253	(101.5)	38	25
24	260	247	(101.0)	37	24
23	254	243	(100.0)	36	23
22	248	237	(99.0)	35	22
21	243	231	(98.5)	35	21
20	238	226	97.8	34	20
(18)	230	219	96.7	33	(18)
(16)	222	212	95.5	32	(16)
(14)	213	203	93.9	31	(14)
(12)	204	194	92.3	29	(12)
(10)	196	187	90.7	28	(10)
(8)	188	179	89.5	27	(8)
(6)	180	171	87.1	26	(6)
(4)	173	165	85.5	25	(4)
(2)	166	158	83.5	24	(2)
(0)	160	152	81.7	24	(0)

Surface Roughness vs Machining Methods

Method	Roughness Range μm	Up to	Up to	Up to	Up to	Up to	Up to	Up to	Up to	Up to	Up to	Up to	Up to	Up to
		0.1	0.2	0.4	0.8	1.5	3	6	12	25	50	100	200	400
Symbols		No symbols or ~												
Forging	FG													
Casting	C													
Die casting	DC													
Hot rolling	HR													
Cold rolling	CR													
Drawing	DW													
Extruding	EX													
Tumbling	TU													
Sand blasting	SB													
Rolling	RL													
Face milling	FM													
Planing	P													
Slotting	SL													
Milling	M													
Fine Boring	FB													
File finishing	FF													
Rounding	T													
Boring	B													
Drilling	D													
Reaming	DR													
Broaching	BR													
Shaving	SV													
Grinding	G													
Honing	GH													
Super-finishing	GSP													
Buffing	SPBF													
Papering	FCA													
Lapping	FL													
Hydro-honing	SPLH													
Burnishing	RLB													
Roller finishing	RF													
Chemical polishing	SPC													
Electrolytic polishing	SPE													

Viscosity Conversion Table

Saybolt SUS (second)	Redwood R (second)	Engler E (second)	Centistoke cSt
35	32.2	1.18	2.7
40	36.2	1.32	4.3
45	40.6	1.46	5.9
50	44.9	1.60	7.4
55	49.1	1.75	8.9
60	53.5	1.88	10.4
65	57.9	2.02	11.8
70	62.3	2.15	13.1
75	67.6	2.31	14.5
80	71.0	2.42	15.8
85	75.1	2.55	17.0
90	79.6	2.68	18.2
95	84.2	2.81	19.4
100	88.4	2.95	20.6
110	97.1	3.21	23.0
120	105.9	3.49	25.0
130	114.8	3.77	27.5
140	123.6	4.04	29.8
150	132.4	4.32	32.1
160	141.1	4.59	34.3
170	150.0	4.88	36.5
180	158.8	5.15	38.8
190	167.5	5.44	41.0
200	176.4	5.72	43.2
220	194	6.28	47.5
240	212	6.85	51.9
260	229	7.38	56.5
280	247	7.95	60.5
300	265	8.51	64.9
325	287	9.24	70.3
350	309	9.95	75.8
375	331	10.7	81.2
400	353	11.4	86.8
425	375	12.1	92.0
450	397	12.8	97.4

Saybolt SUS (second)	Redwood R (second)	Engler E (second)	Centistoke cSt
475	419	13.5	103
500	441	14.2	108
550	485	15.6	119
600	529	17.0	130
650	573	18.5	141
700	617	19.9	152
750	661	21.3	163
800	705	22.7	173
850	749	24.2	184
900	793	25.6	195
950	837	27.0	206
1000	882	28.4	217
1200	1058	34.1	260
1400	1234	39.8	302
1600	1411	45.5	347
1800	1587	51	390
2000	1763	57	433
2500	2204	71	542
3000	2646	85	650
3500	3087	99	758
4000	3526	114	867
4500	3967	128	974
5000	4408	142	1082
5500	4849	156	1150
6000	5290	170	1300
6500	5730	185	1400
7000	6171	199	1510
7500	6612	213	1630
8000	7053	227	1740
8500	7494	242	1850
9000	7943	256	1960
9500	8375	270	2070
10000	8816	284	2200

K

Temperature Conversion Table

How to read the table:

To convert 38°C to degrees Fahrenheit, first find "38" in the middle column (10th line from the top) of the second row, and then read across to the figure on the right in the °F column. 38°C is 100.4°F.

To convert 38°F to degrees Centigrade, find the column on the left to determine that 38°F is 3.3°C.

$$C = \frac{5}{9}(F - 32) \quad F = \frac{9}{5}C + 32$$

°C ← °F	°C	→ °F
-73	-100	-148
-62	-80	-112
-51	-60	-76
-40	-40	-40
-29	-20	-4
-23.3	-10	14
-17.7	0	32
-17.2	1	33.8
-16.6	2	35.6
-16.1	3	37.4
-15.5	4	39.2
-15.0	5	41.0
-14.4	6	42.8
-13.9	7	44.6
-13.3	8	46.4
-12.7	9	48.2
-12.2	10	50.0
-11.6	11	51.8
-11.1	12	53.6
-10.5	13	55.4
-10.0	14	57.2
-9.4	15	59.0
-8.8	16	61.8
-8.3	17	63.6
-7.7	18	65.4
-7.2	19	67.2
-6.6	20	68.0
-6.1	21	69.8
-5.5	22	71.6
-5.0	23	73.4
-4.4	24	75.2
-3.9	25	77.0
-3.3	26	78.8
-2.8	27	80.6
-2.2	28	82.4

°C ← °F	°C	→ °F
-1.6	29	84.2
-1.1	30	86.0
-0.6	31	87.8
0	32	89.6
0.5	33	91.4
1.1	34	93.2
1.6	35	95.0
2.2	36	96.8
2.7	37	98.6
3.3	38	100.4
3.8	39	102.2
4.4	40	104.0
4.9	41	105.8
5.5	42	107.6
6.0	43	109.4
6.6	44	111.2
7.1	45	113.0
7.7	46	114.8
8.2	47	116.6
8.8	48	118.4
9.3	49	120.2
9.9	50	122.0
10.4	51	123.8
11.1	52	125.6
11.5	53	127.4
12.1	54	129.2
12.6	55	131.0
13.2	56	132.8
13.7	57	134.6
14.3	58	136.4
14.8	59	138.2
15.6	60	140.0
16.1	61	141.8
16.8	62	143.6
17.1	63	145.4

°C ← °F	°C	→ °F
17.7	64	147.2
18.2	65	149.0
18.8	66	150.8
19.3	67	152.6
19.9	68	154.4
20.4	69	156.2
21.0	70	158.0
21.5	71	159.8
22.2	72	161.8
22.7	73	163.4
23.3	74	165.2
23.8	75	167.0
24.4	76	168.8
25.0	77	170.6
25.5	78	172.4
26.2	79	174.2
26.8	80	176.0
27.3	81	177.8
27.7	82	179.6
28.2	83	181.4
28.8	84	183.2
29.3	85	185.0
29.9	86	186.8
30.4	87	188.6
31.0	88	190.4
31.5	89	192.2
32.1	90	194.0
32.6	91	195.8
33.3	92	197.6
33.8	93	199.4
34.4	94	201.2
34.9	95	203.0
35.5	96	204.8
36.1	97	206.6
36.6	98	208.4

°C ← °F	°C	→ °F
37.1	99	210.2
37.7	100	212
38	100.4	212.7
43	110	230
49	120	248
54	130	266
60	140	284
65	150	302
71	160	320
76	170	338
83	180	356
88	190	374
93	200	392
121	250	482
149	300	572
177	350	662
204	400	752
232	450	842
260	500	932
288	550	1022
315	600	1112
343	650	1202
371	700	1292
399	750	1382
426	800	1472
454	850	1562
482	900	1652
510	950	1742
538	1000	1832
538	1000	1832
593	1100	2012
648	1200	2192
704	1300	2372
760	1400	2552
815	1500	2732



■ KLUBER Lubricants for Oil Seal Use

NOK has created the NOK KLUBER Company through a merger with KLUBER LUBRICATION of Germany, which has over a century of experience in the field of specialized lubricants, and also supplies KLUBER lubricants for oil seal use.

NOK KLUBER combines proven technologies from both companies, resolving various lubrication problems by utilizing our vast experience and extensive developmental activities.

NOK KLUBER has established a complete system to respond to user needs for extreme conditions, such as high or low temperatures, high speeds, or high loads, based on our unparalleled experience.

1. NOK KLUBER Lubricants

•General parts lubrication parts

Anti-friction bearings, Slide bearings, Chains, Toothed wheels, various kinds of valves.

•Lubricants for specialized applications

Oxygen systems, vacuums, slide members, food processing machinery, textile machinery, various conveyers.

•Other specialized lubricants

Silicone lubricants, solid lubricants, special mold lubricants, preservatives, and lubricants for oil seal use.

2. Features of NOK KLUBER Lubricants

•Extremely high or low temperatures

Liquid lubricants : -70 to 280°C

Dry lubricants : 1200°C

•High speeds

$\text{Dm} \cdot \text{N}$ value: 1,500,000

•High loads

The load capacity is two to four times that of general lithium grease.

•Long service life

Proven record of 12,000 hours at 200°C

•Resistance to severe application conditions

Excellent resistance to water, steam, seawater, acids, alkalis, and other chemicals

•Compatible with machinery

Does not degrade rubber, resins, plastics, and paint

3. Handling KLUBER Lubricants in Seal Use

•Coating

Apply a coating evenly to the lip contact face. (Refer to the photograph on page G-3.)

For details, refer to the **Special Lubricants Catalog (Cat. 701)**.

KLUBER Lubricants Suitable for Oil Seal Use

Application	Name	Effect on Rubber ^{Note(1)}						Working temperature range (°C)	Consistency (NLGI)	Examples of use	Features
		Nitrile rubber	Acrylic rubber	Silicone rubber	Fluoro-carbon rubber	Chloro-prene rubber	Ethylene propylene rubber				
General	SEALUB S-1	○	○	○	○	○	×	-30~120	2	Automobiles, construction machinery, agricultural machinery	General-purpose lubricant for use with rubber
Water resistant	SEALUB S-8	○	○	×	○	○	○	-40~160	3	Automobiles, household appliances	Excellent resistance to water and steam
Low temperature/high speed	SEALUB S-14	○	○	○	○	○	×	-50~150	2	Automobiles, household electrical appliances	May be used in extremely low and high temperature conditions
Food processing machinery	Klubersynth UH1 64-2403	○	○	○	○	○	×	-30~140	3	Food/beverage producers	USDA H1 approved* Excellent resistance to water and steam
	PARALIQ GTE703	○	○	×	○	○	○	-50~150	3		
High temperature/solvent resistant/chemicals	BARRIERTA L55/2	○	○	○	○	○	○	-35~260	2	Automobiles, chemical plant equipment	Excellent resistance to heat, solvents, and chemicals

Note(1) Effects on rubber
○: Resistance
×: No resistance

{ The indicated effects on rubber are based on a general evaluation. Before use, please check the relevant working conditions. }

*USDA H1 lubricant
A lubricant approved by the U.S. Department of Agriculture (USDA). Its use in areas where it may contact food incidentally or through structural means is permitted.

NOK's Product Portfolio

Sealing products

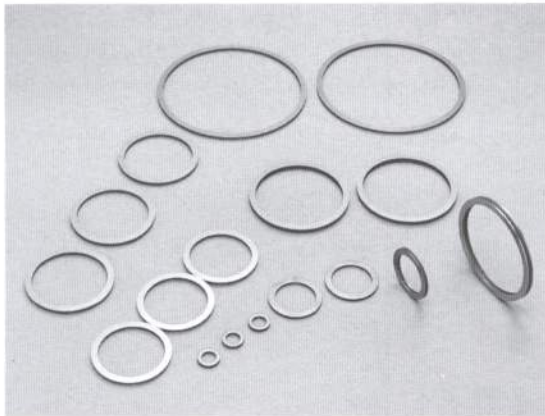

Magnetic fluid dust seals

- Oil seals
- Magnetic fluid seals
- Packings
- O-rings
- Mechanical face seals
- Rubber-coated metal: "Soft Metal" gaskets
- Static metal packings
- Culletts
- Seal washer

Industrial Rubber/Plastic Products



Polyurethane rubber "Iron Rubber" products

- Synthetic rubber materials
- Polyurethane rubber: "Iron Rubber" products
- Polyurethane rubber: "Iron Rubber" belts
- Traffic signs and accessories
- Engineered plastic products
- Phenol resin molding materials

Vibration Isolators

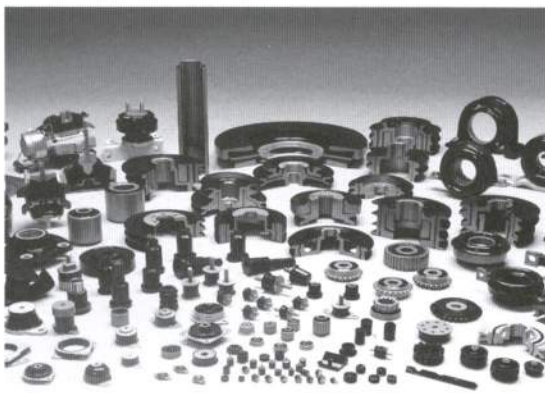

Rubber vibration isolators

- Rubber vibration isolators

Hydro-Pneumatic Equipment



Bladder hydro-pneumatic accumulators

- Bladder hydro-pneumatic accumulator
- Small bladder hydro-pneumatic accumulator: "Minilator"
- Piston hydro-pneumatic accumulator
- Small spherical hydro-pneumatic accumulator: "MU"
- Expansion tank
- Pneumatic equipment

K

Plant Equipment



Metal bellows (welded bellows)

- Metal bellows
- Couplings
- Bellows valves

Electronic Products

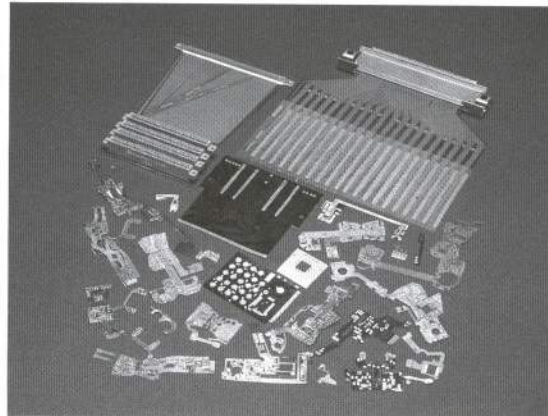

Flexible printed circuits

- Flexible printed circuit boards
- Multi-layer flexible printed circuit board: "Flexboard"
- Hardware products
- Panel keyboard

Optoelectronics Products



Solid-state cameras

- Optoelectronics products
- Solid-state cameras
- High-output solid-state lasers
- Infrared ray sensor: "Thermopile"
- High-speed image processors
- UV/visible/infrared detectors
- Flash tubes/lamps

Functional Products for Industrial Use and Special Applications

- Solenoids
- Actuators
- Inlet control valves
- Valves
- Oil separator/impurity filtration filter: "Raker Filter Separator"
- Lead valves
- High molecular hollow fiber membrane module
- Abrasive-resistant structural materials



Special lubricants

- Special lubricants
- Fluorocarbon water/oil repellent: "Knockguard"
- Fluorocarbon coating material: "Glitopan"
- Oil-less bearing: "Lubless"
- Adapter to prevent cable disconnections: "SY Joint"
- Carbon fiber combined carbon
- Electrodes for electric contact/electrical discharge machining: "Elmet"
- Compressor valves
- Recoil starters

©NOK CORPORATION Printed in Japan

Overseas Sales & Marketing Department Sales & Marketing Division

1-12-15 Shiba Daimon Minato-ku, Tokyo, Japan. Zipcord 105-8585.

The contents is subject to change without notice.

All compatibility data, application information, design & material information and technical deta in this catalogue are compiled as a reference material to make a basic packing selection.

A selected standard design from this catalogue may not comform to the actual use of an application, clue to unknown factors in the application.

Please confirm the actual compatibility of a selected product with your appli-cation before using it.